

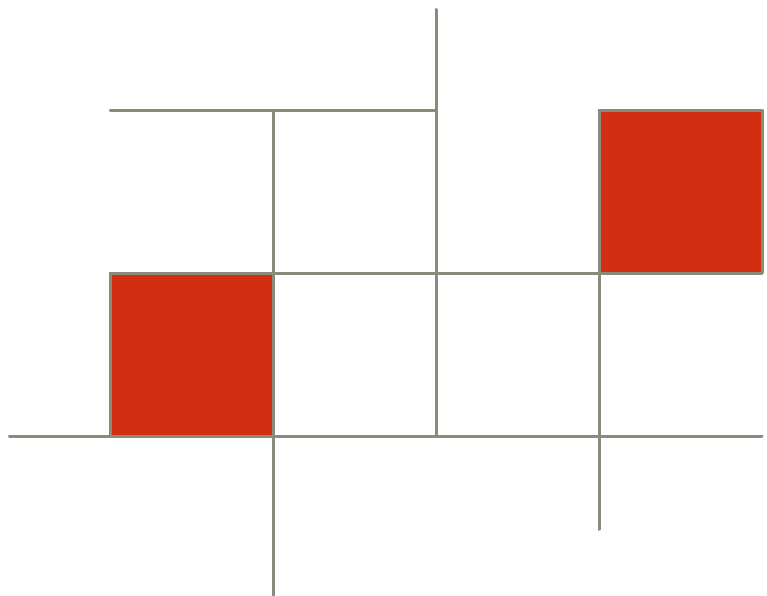


# **Electromagnetic Compatibility and Electrical Safety - Generic Criteria for Network Telecommunications Equipment**

**(A Module of LSSGR, FR-64; TSGR, FR-440; and NEBSFR, FR-2063)**

Telcordia Technologies Generic Requirements  
GR-1089-CORE  
Issue 4, June 2006

***Comments Requested (See Preface)***



## Electromagnetic Compatibility and Electrical Safety

Prepared for Telcordia Technologies, Inc. by: Network Reliability, Operations, and Deployment

Target audience: Telecommunications Service Providers and Equipment Manufacturers

This document replaces: GR-1089-CORE, Issue 3, October 2002.

This document is a module of LSSGR, FR-64; TSGR, FR-440; and NEBSFR, FR-2063.

Technical contact(s):

**Chrysanthos Chrysanthou**  
**(Chairman of Telcordia**  
**Technical Forum)**  
Telcordia  
Phone: + 1.732.699.3357  
E-mail: cchrysan@telcordia.com

**Jeffrey Boksiner**  
Telcordia  
Phone: + 1.732.699.3325  
E-mail: jboksine@telcordia.com

**Randall R. McCarver**  
Telcordia  
Phone: + 1.732.699.5491  
E-mail: rmccarve@telcordia.com

To obtain copies of this document, contact your company's document coordinator or your Telcordia account manager, or call 1.866.672.6997 (USA) or + 1.732.699.6700 (Worldwide), or visit our Web site at <http://telecom-info.telcordia.com>.

Copyright © 1997-2006 Telcordia Technologies, Inc. All rights reserved.

## Trademark Acknowledgments

CLASS is a service mark of Telcordia Technologies, Inc.

NEBS is a trademark of Telcordia Technologies, Inc.

Telcordia and COMMON LANGUAGE are registered trademarks; and CLLI, CLEI, CLFI, CLCI, and NC/NCI are trademarks of Telcordia Technologies, Inc.

All other brand or product names are trademarks of their respective companies or organizations.

## Generic Requirements Notice of Disclaimer

This Generic Requirements document (GR) is published by Telcordia Technologies to inform the industry of the Telcordia view of proposed generic requirements for *Electromagnetic Compatibility and Electrical Safety*. The generic requirements contained herein are subject to review and change, and superseding generic requirements regarding this subject may differ from those in this document. Telcordia reserves the right to revise this document for any reason (consistent with applicable provisions of the Telecommunications Act of 1996 and applicable FCC rules).

TELCORDIA AND THE OTHER PARTICIPANTS IDENTIFIED IN THE PREFACE MAKE NO REPRESENTATION OR WARRANTY, EXPRESSED OR IMPLIED, WITH RESPECT TO THE SUFFICIENCY, ACCURACY, OR UTILITY OF ANY INFORMATION OR OPINION CONTAINED HEREIN.

TELCORDIA AND THE OTHER PARTICIPANTS EXPRESSLY ADVISE THAT ANY USE OF OR RELIANCE UPON SAID INFORMATION OR OPINION IS AT THE RISK OF THE USER AND THAT NEITHER TELCORDIA NOR ANY OTHER PARTICIPANT SHALL BE LIABLE FOR ANY DAMAGE OR INJURY INCURRED BY ANY PERSON ARISING OUT OF THE SUFFICIENCY, ACCURACY, OR UTILITY OF ANY INFORMATION OR OPINION CONTAINED HEREIN.

LOCAL CONDITIONS MAY GIVE RISE TO A NEED FOR ADDITIONAL PROFESSIONAL INVESTIGATIONS, MODIFICATIONS, OR SAFEGUARDS TO MEET SITE, EQUIPMENT, ENVIRONMENTAL SAFETY OR COMPANY-SPECIFIC REQUIREMENTS. IN NO EVENT IS THIS INFORMATION INTENDED TO REPLACE FEDERAL, STATE, LOCAL, OR OTHER APPLICABLE CODES, LAWS, OR REGULATIONS. SPECIFIC APPLICATIONS WILL CONTAIN VARIABLES UNKNOWN TO OR BEYOND THE CONTROL OF TELCORDIA. AS A RESULT, TELCORDIA CANNOT WARRANT THAT THE APPLICATION OF THIS INFORMATION WILL PRODUCE THE TECHNICAL RESULT OR SAFETY ORIGINALLY INTENDED.

This GR is not to be construed as a suggestion to anyone to modify or change any product or service, nor does this GR represent any commitment by anyone, including but not limited to Telcordia and the other participants in the development of this Telcordia GR, to purchase, manufacture, or sell any product with the described characteristics.

Readers are specifically advised that any entity may have needs, specifications, or requirements different from the generic descriptions herein. Therefore, anyone wishing to know any entity's needs, specifications, or requirements should communicate directly with that entity.

Nothing contained herein shall be construed as conferring by implication, estoppel, or otherwise any license or right under any patent, whether or not the use of any information herein necessarily employs an invention of any existing or later issued patent.

TELCORDIA DOES NOT HEREBY RECOMMEND, APPROVE, CERTIFY, WARRANT, GUARANTEE, OR ENDORSE ANY PRODUCTS, PROCESSES, OR SERVICES, AND NOTHING CONTAINED HEREIN IS INTENDED OR SHOULD BE UNDERSTOOD AS ANY SUCH RECOMMENDATION, APPROVAL, CERTIFICATION, WARRANTY, GUARANTY, OR ENDORSEMENT TO ANYONE.

For general information about this or any other Telcordia documents, please contact:

Telcordia Customer Service  
One Telcordia Drive, Room 1B-180  
Piscataway, NJ 08854-4182  
1.866.672.6997 (USA)  
+ 1.732.699.6700 (Worldwide)  
+ 1.732.336.2226 (FAX)  
e-mail: [document-info@telcordia.com](mailto:document-info@telcordia.com)  
web site: <http://telecom-info.telcordia.com>

## Table of Contents

### 1 Introduction

1.1 Purpose and Scope . . . . .	1-1
1.2 Items Not Covered in This GR . . . . .	1-2
1.3 Requirements Terminology . . . . .	1-2
1.4 Requirement Labeling Conventions . . . . .	1-3
1.4.1 Numbering of Requirement and Related Objects . . . . .	1-3
1.4.2 Requirement, Conditional Requirement, and Objective Identification . . . . .	1-4
1.5 Organization . . . . .	1-4
1.6 Reasons for GR-1089-CORE, Issue 4 . . . . .	1-5
1.6.1 Reasons for GR-1089-CORE, Issue 3 . . . . .	1-7
1.7 Application of This Document . . . . .	1-8
1.8 Guidelines for Equipment Evaluation . . . . .	1-9
1.9 Documentation . . . . .	1-10
1.9.1 General . . . . .	1-10
1.9.2 Root Cause Analysis . . . . .	1-10
1.10 Number of Samples To Be Tested . . . . .	1-11
1.11 Relation to Other Telcordia Documents . . . . .	1-11

### 2 System-Level Electrostatic Discharge (ESD) and Electrical Fast Transient (EFT)

2.1 System-Level Electrostatic Discharge (ESD) . . . . .	2-1
2.1.1 Overview . . . . .	2-1
2.1.2 ESD Immunity Criteria . . . . .	2-1
2.1.2.1 Immunity Criteria — Normal Operation . . . . .	2-2
2.1.2.2 Immunity Criteria — Installation and Maintenance . . . . .	2-2
2.1.2.3 ESD Warning Label Requirements . . . . .	2-2
2.1.2.4 Equipment-Specific Requirements . . . . .	2-3
2.1.3 Service-Affecting Responses and Manual Interventions . . . . .	2-3
2.1.4 ESD Test Methods and Procedures . . . . .	2-3
2.1.4.1 Test Methods — Normal Operation . . . . .	2-4
2.1.4.2 Test Methods — Installation and Maintenance . . . . .	2-4
2.1.4.3 Selection of Test Points . . . . .	2-4
2.1.4.4 EUT Operating Conditions . . . . .	2-5
2.1.4.5 ESD Test Site . . . . .	2-6
2.2 Electrical Fast Transient (EFT) . . . . .	2-6
2.2.1 EFT Test Methods and Procedures . . . . .	2-7

### 3 Electromagnetic Interference

3.1 General . . . . .	3-1
3.1.1 Overview . . . . .	3-1
3.1.2 Intent of EMI Criteria . . . . .	3-1
3.1.3 FCC Part 15 Criteria . . . . .	3-2
3.1.4 FCC Part 68 and ACTA Technical Criteria . . . . .	3-3
3.1.5 Documentation . . . . .	3-4
3.2 Emission Criteria . . . . .	3-4
3.2.1 Radiated Emission Criteria . . . . .	3-5

- 3.2.1.1 Electric Fields Radiated Emission Criteria for Unintentional Radiators . . . . . 3-5
- 3.2.1.2 Electric Fields Radiated Emission Criteria for Intentional Radiators . . . . . 3-9
- 3.2.1.3 Magnetic Fields Radiated Emission Requirement . . . . . 3-10
- 3.2.2 Conducted Emission Criteria for Power Ports . . . . . 3-10
  - 3.2.2.1 Conducted Emission Requirements for AC Power Ports . . . . . 3-11
  - 3.2.2.2 Conducted Emission Requirements for AC and DC Power - Current . . . . . 3-11
- 3.2.3 Conducted Emission Criteria for Telecommunications Ports . . . . . 3-12
  - 3.2.3.1 Conducted Emission Requirements for Signal Leads — Current . . . . . 3-12
  - 3.2.3.2 Conducted Emission Requirements for Analog Voiceband Leads . . . . . 3-13
  - 3.2.3.3 Conducted Emission Objectives for Telecommunications Leads . . . . . 3-14
- 3.3 Immunity Criteria . . . . . 3-17
  - 3.3.1 Radiated Immunity Criteria . . . . . 3-18
    - 3.3.1.1 Electric Fields Radiated Immunity Criteria with Doors and Covers Closed . . . . . 3-18
    - 3.3.1.2 Electric Fields Radiated Immunity Criteria with Doors and Covers Open . . . . . 3-18
  - 3.3.2 Conducted Immunity Criteria for AC and DC Power Ports . . . . . 3-18
  - 3.3.3 Conducted Immunity Criteria for Telecommunications Ports . . . . . 3-19
    - 3.3.3.1 Conducted Immunity Requirements for Signal Leads . . . . . 3-19
    - 3.3.3.2 Conducted Immunity Objectives for Voiceband and Telecommunications Leads . . . . . 3-19
- 3.4 Measurement Procedures Associated with Emissions . . . . . 3-20
  - 3.4.1 Scope . . . . . 3-20
  - 3.4.2 Related Standards . . . . . 3-20
  - 3.4.3 Measuring Instrumentation . . . . . 3-20
    - 3.4.3.1 General . . . . . 3-20
    - 3.4.3.2 Analog Voiceband Leads Emissions Measurement Instrumentation . . . . . 3-21
    - 3.4.3.3 Telecommunications Leads Emissions Measurement Instrumentation . . . . . 3-22
    - 3.4.3.4 Measuring Instrument Calibration . . . . . 3-22
    - 3.4.3.5 Detector Function Selection and Bandwidth . . . . . 3-22
    - 3.4.3.6 Antennas . . . . . 3-23
  - 3.4.4 General Test Conditions . . . . . 3-27
    - 3.4.4.1 Emission Measurement Uncertainty . . . . . 3-27
    - 3.4.4.2 Testing at an Open-Area Test Site (OATS) . . . . . 3-27
    - 3.4.4.3 Testing at User's Installation (On-Premises Testing) . . . . . 3-27
    - 3.4.4.4 Testing in a Shielded Enclosure . . . . . 3-29
    - 3.4.4.5 Subsystem Emission Limits Allocation . . . . . 3-29
    - 3.4.4.6 Units of Measurement . . . . . 3-30
    - 3.4.4.7 Data Reporting Format . . . . . 3-30
    - 3.4.4.8 Test Conditions for EUT . . . . . 3-30
    - 3.4.4.9 Test Environment . . . . . 3-33
    - 3.4.4.10 Arrangements of EUT . . . . . 3-34
    - 3.4.4.11 Arrangements of Intentional Radiators . . . . . 3-34

3.4.5	Conducted Emissions Measurements . . . . .	3-34
3.4.5.1	Measurement Procedures . . . . .	3-35
3.4.6	Radiated Emission Measurements . . . . .	3-40
3.4.6.1	Determination of Test Radial . . . . .	3-40
3.4.6.2	Radiated Radio Noise Tests . . . . .	3-40
3.4.7	Retesting With System Evolution and Growth . . . . .	3-41
3.4.7.1	System Evolution . . . . .	3-41
3.4.7.2	System Growth . . . . .	3-42
3.5	Measurement Procedures Associated With Immunity . . . . .	3-42
3.5.1	Scope . . . . .	3-42
3.5.2	Measuring Instrumentation . . . . .	3-42
3.5.2.1	Receivers . . . . .	3-42
3.5.2.2	Current Probes . . . . .	3-42
3.5.2.3	Antennas . . . . .	3-42
3.5.2.4	Signal Sources . . . . .	3-43
3.5.3	Test Conditions for EUT . . . . .	3-43
3.5.3.1	Non-Switching Systems . . . . .	3-43
3.5.3.2	Bit Error Rate (BER) . . . . .	3-44
3.5.3.3	Synchronization . . . . .	3-44
3.5.3.4	Voiceband Noise . . . . .	3-44
3.5.4	Data Reporting Format . . . . .	3-45
3.5.5	Radiated Immunity Measurements . . . . .	3-46
3.5.5.1	Shielded Enclosures . . . . .	3-46
3.5.5.2	Subsystem Testing . . . . .	3-46
3.5.5.3	Measurement Procedures . . . . .	3-46
3.5.6	Conducted Immunity Measurements . . . . .	3-52
3.5.6.1	Test Signal Modulation . . . . .	3-53
3.5.6.2	Frequency Scanning and Test Selection . . . . .	3-53
3.5.6.3	Calibration of Test Signal . . . . .	3-53
3.5.6.4	AC and DC Leads (Common-Mode Injection) . . . . .	3-53
3.5.6.5	Telecommunications Ports - Voiceband, Telecommunications and Signal Leads (Common-Mode Injection) . . . . .	3-54

## 4 Lightning and AC Power Fault

4.1	Overview . . . . .	4-1
4.2	Electrical Protection on Paired-Conductor Systems . . . . .	4-1
4.2.1	Voltage-Limiting Protectors . . . . .	4-2
4.2.2	Current-Limiting Protectors . . . . .	4-2
4.2.3	Fuse Links . . . . .	4-2
4.3	Lightning on Paired-Conductor Cables . . . . .	4-3
4.3.1	Longitudinal Surges . . . . .	4-3
4.3.2	Metallic Surges . . . . .	4-3
4.4	AC Power Fault on Paired-Conductor Cables . . . . .	4-4
4.4.1	Power Contact to Telecommunications OSP . . . . .	4-4
4.4.2	Fault Induction From Electric Power Lines . . . . .	4-4
4.5	Characterization of Test Generators . . . . .	4-4
4.6	Criteria for Equipment Interfacing With Telecommunications Ports . . . . .	4-9
4.6.1	First-Level and Second-Level Criteria . . . . .	4-9
4.6.2	Testing Conditions of Telecommunications Ports . . . . .	4-10

- 4.6.2.1 Lightning Surge and AC Power Fault Test Connections (Telecommunications Port) . . . . . 4-11
- 4.6.2.2 EUT Grounding . . . . . 4-13
- 4.6.2.3 DC Return . . . . . 4-13
- 4.6.2.4 Test Setup for Equipment Providing or Receiving Remote Power 4-13
- 4.6.3 Number of Samples To Be Tested . . . . . 4-21
- 4.6.4 Fire Hazard Indicator for Second-Level Criteria . . . . . 4-21
- 4.6.5 Short-Circuit Tests (Telecommunications Type 1, 3, and 5 Ports) . . . 4-22
- 4.6.6 First-Level Lightning Surge Tests (Telecommunications Type 1, 3, and 5 Ports) . . . . . 4-22
  - 4.6.6.1 Equipment Ports With Secondary Protection . . . . . 4-24
- 4.6.7 First-Level Lightning Protection Tests (Telecommunications Type 1, 3, and 5 Ports) . . . . . 4-26
- 4.6.8 Second-Level Lightning Surge Tests (Telecommunications Type 1, 3, and 5 Ports) . . . . . 4-28
  - 4.6.8.1 Equipment Ports With Secondary Protection . . . . . 4-29
- 4.6.9 First-Level Intra-Building Lightning Surge Tests (Telecommunications Type 2 and 4 Ports) . . . . . 4-30
  - 4.6.9.1 Ports Connected to Unshielded Cables . . . . . 4-31
  - 4.6.9.2 Ports Connected to Shielded Cables . . . . . 4-34
- 4.6.10 First-Level AC Power Fault Tests (Telecommunications Type 1, 3, and 5 Ports) . . . . . 4-36
  - 4.6.10.1 Equipment Ports With Secondary Protection . . . . . 4-36
- 4.6.11 Current-Limiting Protector Tests for Equipment To Be Located at Network Facilities (Type 1 Telecommunications Port) . . . . . 4-39
  - 4.6.11.1 Test Procedure . . . . . 4-40
- 4.6.12 Second-Level AC Power Fault Tests for Equipment To Be Located at Network Facilities (Type 1 Telecommunications Port) . . . . . 4-45
  - 4.6.12.1 Equipment Ports With Secondary Protection . . . . . 4-46
- 4.6.13 Second-Level AC Power Fault Tests for Series-Type Equipment To Be Located at Network Facilities (Type 1 Telecommunications Port) . . . . . 4-48
- 4.6.14 Fusing Coordination Tests for Equipment To Be Located on Customer Premises and OSP Facilities (Type 3 and 5 Telecommunications Ports) . . . . . 4-49
  - 4.6.14.1 Test Procedure . . . . . 4-49
- 4.6.15 Second-Level AC Power Fault Tests for Equipment To Be Located on Customer Premises and OSP Facilities (Type 3 and 5 Telecommunications Ports) . . . . . 4-51
  - 4.6.15.1 Equipment Ports With Secondary Protection . . . . . 4-53
  - 4.6.15.2 Tests for Ungrounded Exposed Conductive Surfaces . . . . . 4-55
- 4.6.16 Second-Level AC Power Fault Tests for Series-Type Equipment To Be Located on Customer Premises and OSP Facilities (Type 3 and 5 Telecommunications Ports) . . . . . 4-56
- 4.6.17 Second-Level Intra-Building AC Power Fault Tests for Equipment To Be Located on Customer Premises (Type 4 Telecommunications Port) 4-57
- 4.7 Lightning Protection Tests for Equipment To Be Located in High-Exposure Customer Premises and OSP Facilities (Type 3 and 5 Telecommunications Ports) . . . . . 4-58
- 4.8 Criteria for Equipment Interfacing With Agreed Primary Protection . . . . . 4-60



4.9	Criteria for Equipment With Integrated Primary Protection . . . . .	4-64
4.9.1	Equipment Classification . . . . .	4-66
4.9.2	Protector Requirements . . . . .	4-68
4.9.3	Lightning Surge and Power Fault Tests for Protected Circuits . . . . .	4-69
4.9.3.1	Overcurrent Protection Coordination Test for Protected Circuits . . . . .	4-71
4.9.4	Fusing Coordination for Unprotected Circuits . . . . .	4-71
4.9.4.1	Fusing Coordination for Circuits Suitable for Fusing . . . . .	4-72
4.9.4.2	Fusing Coordination Test for Circuits Not Acting as Fuse Links . . . . .	4-74
4.9.5	Dielectric Withstand . . . . .	4-75
4.9.6	Stub Cable Requirements . . . . .	4-76
4.9.7	AC Power Fault Immunity . . . . .	4-76
4.9.8	Lightning Surge Tests . . . . .	4-77
4.9.8.1	Lightning Surge Tests for Severe Climatic Conditions . . . . .	4-78
4.10	Criteria for Equipment Interfacing With Coaxial Cable Ports . . . . .	4-78
4.10.1	Number of Samples To Be Tested . . . . .	4-80
4.10.2	Short-Circuit Tests . . . . .	4-80
4.10.3	Broadband Communications Equipment Intended for Use Without External Protectors . . . . .	4-80
4.10.3.1	First-Level Lightning and Power Fault Tests . . . . .	4-81
4.10.3.2	Second-Level Lightning and Power Fault Tests . . . . .	4-82
4.10.4	Broadband Communications Equipment Intended for Use With an External Protector . . . . .	4-84
4.10.4.1	First-Level Lightning and Power Fault Tests . . . . .	4-84
4.10.4.2	Second-Level Lightning and Power Fault Tests . . . . .	4-85
4.10.5	First-Level Intrabuilding Surge Tests . . . . .	4-87
4.10.6	Additional Criteria for Equipment Intended for the OSP . . . . .	4-88
4.11	Lightning Criteria for Equipment Interfacing With Antennas . . . . .	4-89
4.12	Lightning Criteria for Equipment Interfacing With AC Power Port(s) . . . . .	4-90
4.12.1	Equipment Used in Facilities With an External SPD . . . . .	4-91
4.12.2	Equipment Used in Facilities Without an External SPD . . . . .	4-92
4.13	Lightning Criteria for Equipment Interfacing With DC Power Port(s) . . . . .	4-93
4.13.1	Tests Directly on DC Power Port . . . . .	4-93

## 5 Steady-State Power Induction

5.1	Overview . . . . .	5-1
5.2	Longitudinal Induction Criteria for Long (> 20 kft) Loops . . . . .	5-1
5.2.1	Longitudinal Induction Test Circuit for Long (> 20 kft) Loops . . . . .	5-2
5.2.2	Calibration Procedure . . . . .	5-5
5.2.3	Test Procedures . . . . .	5-5
5.2.3.1	Test Procedure for a CO Switching System Line Circuit . . . . .	5-5
5.2.4	Performance Criteria . . . . .	5-7
5.2.5	Noise Performance for Voiceband Circuits . . . . .	5-7
5.3	Longitudinal Induction Criteria for Short (< 20 kft) Loops . . . . .	5-8
5.3.1	Longitudinal Induction Test Circuit for Short (< 20 kft) Loops . . . . .	5-8
5.3.2	Calibration Procedure . . . . .	5-11
5.3.3	Test Procedures . . . . .	5-11
5.3.3.1	Test Procedure for ISDN Technology . . . . .	5-11
5.3.3.2	Test Procedure for DSL Technologies . . . . .	5-12
5.3.3.3	Test Procedure for RT Line Circuits of a DLC System . . . . .	5-12

- 5.3.4 Performance Criteria . . . . . 5-13
- 5.3.5 Noise Performance for Voiceband Circuits . . . . . 5-13
- 5.4 Longitudinal Induction Criteria for Analog Trunks . . . . . 5-16
  - 5.4.1 Longitudinal Induction Test Circuit for Trunks . . . . . 5-17
  - 5.4.2 Calibration Procedure . . . . . 5-20
  - 5.4.3 Test Procedure . . . . . 5-20
    - 5.4.3.1 Test Procedure for Analog Trunk Circuits . . . . . 5-20
    - 5.4.3.2 Test Procedure for DLC System Interfaces Between RT and COT . . . . . 5-21
  - 5.4.4 Performance Criteria . . . . . 5-22
  - 5.4.5 Noise Performance for Voiceband Circuits . . . . . 5-22
- 5.5 Longitudinal Induction Criteria for Coaxial Cables . . . . . 5-23
  - 5.5.1 Longitudinal Induction Test Circuit for Coaxial Cables . . . . . 5-23
  - 5.5.2 Test Procedure . . . . . 5-24
  - 5.5.3 Performance Criteria . . . . . 5-25

**6 DC Potential Difference**

**7 Electrical Safety Criteria**

- 7.1 Overview . . . . . 7-1
- 7.2 Listing Requirements . . . . . 7-1
- 7.3 Classification of Voltages . . . . . 7-2
  - 7.3.1 Continuous Voltage and Current Limits . . . . . 7-2
    - 7.3.1.1 Class A1 Voltage Limits . . . . . 7-4
    - 7.3.1.2 Class A2 Voltage Limits . . . . . 7-7
    - 7.3.1.3 Class A3 Voltage Limits . . . . . 7-10
    - 7.3.1.4 Class AB Voltage Limits . . . . . 7-13
    - 7.3.1.5 Class B Voltage Limits . . . . . 7-13
    - 7.3.1.6 Class C Voltage Limits . . . . . 7-13
- 7.4 Continuous Source Requirements . . . . . 7-13
  - 7.4.1 Class A1 Voltage Accessibility Requirements . . . . . 7-16
  - 7.4.2 Class A2 Voltage Accessibility Requirements . . . . . 7-16
  - 7.4.3 Class A3 Voltage Accessibility Requirements . . . . . 7-16
  - 7.4.4 Class AB Voltage Accessibility Requirements . . . . . 7-17
  - 7.4.5 Class B Voltage Accessibility Requirements . . . . . 7-17
  - 7.4.6 Class C Voltage Accessibility Requirements . . . . . 7-17
- 7.5 Duration-Limited Source Requirements . . . . . 7-17
  - 7.5.1 Interrupted/Tripped Sources . . . . . 7-17
    - 7.5.1.1 Ring-Trip Test Procedure . . . . . 7-18
  - 7.5.2 Transient Sources . . . . . 7-19
- 7.6 Power Limitation Requirement . . . . . 7-20
- 7.7 Leakage Currents From Exposed Surfaces . . . . . 7-21
  - 7.7.1 General Considerations . . . . . 7-21
  - 7.7.2 Leakage Current Requirements . . . . . 7-22
    - 7.7.2.1 Leakage Current Requirements for Large Area Contact . . . . . 7-22
    - 7.7.2.2 Leakage Current Requirements for Small Area Contact . . . . . 7-22
    - 7.7.2.3 Leakage Current Between Surfaces of Equipment . . . . . 7-22

## 8 Corrosion

- 8.1 Polarity of DC Voltages Applied to OSP Cabling . . . . . 8-1
- 8.2 Magnitude of DC Voltages Applied to OSP Cabling . . . . . 8-1

## 9 Bonding and Grounding

- 9.1 Scope . . . . . 9-1
- 9.2 General Requirements Principles . . . . . 9-1
- 9.3 Equipment Grounding Systems . . . . . 9-2
  - 9.3.1 Common Bonding Network (CBN) . . . . . 9-3
  - 9.3.2 Isolated Bonding Network (IBN) . . . . . 9-3
- 9.4 AC Equipment Grounding . . . . . 9-4
- 9.5 Communication Equipment Grounding . . . . . 9-4
  - 9.5.1 Network Telecommunication Facilities . . . . . 9-5
  - 9.5.2 Locations Where the NEC Applies . . . . . 9-5
  - 9.5.3 Outside Plant . . . . . 9-6
- 9.6 Equipment Unit Bonding and Grounding . . . . . 9-6
- 9.7 Provisions for Equipment Unit Assembly Bonding and Grounding . . . . . 9-7
  - 9.7.1 Connectors and Connection Methods for Equipment Unit Assemblies . . . . . 9-8
  - 9.7.2 Bonding of Circuit Packs . . . . . 9-8
- 9.8 DC Power System Grounding . . . . . 9-9
  - 9.8.1 Centralized Power Sources . . . . . 9-9
  - 9.8.2 Embedded Power Sources . . . . . 9-9
  - 9.8.3 Bonding of Battery Return (BR) Input Terminals . . . . . 9-12
- 9.9 Bonding and Grounding Conductor and Connection Requirements . . . . . 9-12
  - 9.9.1 Bonding and Grounding Conductors . . . . . 9-13
  - 9.9.2 Connections . . . . . 9-13
  - 9.9.3 Connectors . . . . . 9-14
- 9.10 Short-Circuit Tests . . . . . 9-14
  - 9.10.1 DC Power Sources . . . . . 9-14
  - 9.10.2 AC Power Sources . . . . . 9-17
- 9.11 Other Grounding Considerations . . . . . 9-18
- 9.12 Compatibility of Former IBN Equipment With CBN Currents . . . . . 9-18
  - 9.12.1 Test Conditions for EUT . . . . . 9-18
    - 9.12.1.1 Conditioning of the EUT . . . . . 9-18
    - 9.12.1.2 Interfacing Units and Simulators . . . . . 9-18
    - 9.12.1.3 DC Power Leads . . . . . 9-19
    - 9.12.1.4 Bonding Conductors . . . . . 9-19
    - 9.12.1.5 Shelf-Mounted EUT . . . . . 9-20
    - 9.12.1.6 Reference Plane . . . . . 9-20
    - 9.12.1.7 Test Environment . . . . . 9-20
  - 9.12.2 Identification of Test Points . . . . . 9-20
  - 9.12.3 DC Fault Test . . . . . 9-21
  - 9.12.4 Frame EFT Test . . . . . 9-22
    - 9.12.4.1 Laboratory Arrangement of the EUT . . . . . 9-23
    - 9.12.4.2 In-Situ Arrangement of the EUT . . . . . 9-24
  - 9.12.5 Frame Surge Test . . . . . 9-24
    - 9.12.5.1 Laboratory Arrangement of the EUT . . . . . 9-25
    - 9.12.5.2 In-Situ Arrangement of the EUT . . . . . 9-25
  - 9.12.6 AC Fault Test . . . . . 9-26

9.13 Grounding Connector for Equipment With Integrated Primary Protection . . . 9–28  
9.13.1 Grounding Conductors in the EIPP . . . . . 9–29

**10 Criteria for DC Power Port of Telecommunications Load Equipment**

10.1 Input DC Voltage . . . . . 10–1  
10.2 Minimum Operating Voltage . . . . . 10–1  
10.3 Undervoltage Transient . . . . . 10–2  
10.4 Overvoltage Transient . . . . . 10–3  
10.5 Impulse Transient . . . . . 10–4  
10.6 Single Transient . . . . . 10–4  
10.7 Noise Returned by the Network Equipment (Noise Emission) . . . . . 10–5  
10.7.1 Voice Frequency Noise Emission . . . . . 10–5  
10.7.2 Wideband Frequency Noise Emission . . . . . 10–5  
10.7.3 Broadband Noise Emission . . . . . 10–5  
10.8 Power Input Noise Immunity . . . . . 10–6  
10.8.1 Voice Frequency Noise Immunity . . . . . 10–6  
10.8.2 Wideband Frequency Noise Immunity . . . . . 10–6  
10.8.3 Broadband Noise Immunity . . . . . 10–6

**Appendix A: Definition of Double-Exponential Impulse Waveform**

**Appendix B: Application Guidelines**

**Appendix C: References**

**Appendix D: Definitions**

**Appendix E: Acronyms**

**Requirement-Object Index**

## List of Figures

Figure 3-1	<b>R3-2 [8]</b> Requirement and <b>O3-3 [9]</b> Objective Limits for Class-A Electric Field Emissions at 3-Meter and 10-Meter Distances . . . . .	3-7
Figure 3-2	<b>R3-4 [9]</b> Requirement Limits for Electric Field Emissions at 3-Meter and 10-Meter Distances . . . . .	3-9
Figure 3-3	Conducted Emissions Limits on Signal Leads . . . . .	3-13
Figure 3-4	Analog Voiceband Leads Conducted Emission Limits (Metallic) . . . . .	3-16
Figure 3-5	Analog Voiceband Leads Conducted Emission Limits (Longitudinal) . . . . .	3-17
Figure 3-6	Termination Networks for Conducted Measurements of Analog Voiceband Leads (Metallic and Longitudinal) . . . . .	3-25
Figure 3-7	Balun Termination (Metallic and Longitudinal), 12 kHz to 6 MHz . . . . .	3-26
Figure 3-8	Test Setup for Conducted Emission Tests on AC and DC Power Ports (Current) . . . . .	3-38
Figure 3-9	Test Setup for Conducted Emission Tests on Signal and Telecommunications Leads . . . . .	3-39
Figure 3-10	Test Configuration for Measuring Conducted Emissions From Analog Voiceband Leads . . . . .	3-39
Figure 3-11	Synchronization Test Configuration . . . . .	3-45
Figure 3-12	Cable Arrangement for EUTs With Overhead Cables . . . . .	3-50
Figure 3-13	Injection Probe Calibration Setup . . . . .	3-55
Figure 3-14	Test Setup for Conducted Immunity Tests on AC and DC Power Ports . . . . .	3-56
Figure 3-15	Test Setup for Conducted Immunity Tests for Telecommunications Ports (Voiceband, Signal, and Telecommunications Leads) . . . . .	3-57
Figure 4-1	Typical Lightning or AC Power Test Generator . . . . .	4-8
Figure 4-2	Application of Lightning and AC Power Fault Test Voltages . . . . .	4-12
Figure 4-3	Example Test Circuit for Longitudinal Lightning Surge Test — Two-Wire Interface Configuration A5 . . . . .	4-15
Figure 4-4	Example Test Circuit for Metallic Lightning Surge Test — Two-Wire Interface Configuration A1 or A2 . . . . .	4-16
Figure 4-5	Example Test Circuit for Longitudinal Lightning Surge Test — Four-Wire Interface Configuration A5 or A6 . . . . .	4-17
Figure 4-6	Example Test Circuit for Metallic Lightning Surge Test — Four-Wire Interface Configuration A1, A2, A3, or A4 . . . . .	4-18
Figure 4-7	Example Test Circuit for Longitudinal Lightning Surge Test — Two-Wire Interface Configuration A5 . . . . .	4-19
Figure 4-8	Example Test Circuit for Metallic Lightning Surge Test — Two-Wire Interface Configuration A1 or A2 . . . . .	4-20
Figure 4-9	Test Arrangement for Determining Protection Coordination . . . . .	4-28
Figure 4-10	Test Circuit for Multi-Pair Ports — Metallic Test (Applies to One Conductor at a Time) . . . . .	4-34
Figure 4-11	Test Circuit for Multi-Pair Ports — Longitudinal Test . . . . .	4-34
Figure 4-12	Test Circuit for Paired-Conductor Ports Providing a Connection Means for the Shielded Cable . . . . .	4-36
Figure 4-13	High-Impedance Inductive Source Test Circuit . . . . .	4-39
Figure 4-14	Upper Limit of Time-Current Characteristic of External Current-Limiter Indicator/Wiring Simulator . . . . .	4-42

Figure 4-15	Second-Level AC Power Fault Test Arrangement Using External Current-Limiter Indicator/Wiring Simulator . . . . .	4-43
Figure 4-16	Second-Level AC Power Fault Pair-to-Pair Test Arrangement for Four-Wire Interfaces Using External Current-Limiter Indicator/Wiring Simulator . . . . .	4-44
Figure 4-17	Longitudinal Test Circuit for Equipment To Be Located on High-Exposure Customer Premises and OSP Facilities . . . . .	4-60
Figure 4-18	Illustration of Components and Circuits in EIPP . . . . .	4-66
Figure 4-19	Test Circuit for Coaxial Cable Ports Providing a Connection Means for the Shielded Cable . . . . .	4-88
Figure 4-20	Test Circuit for Lightning Test on DC Power Port . . . . .	4-94
Figure 5-1	Longitudinal Induction Test Circuit for Long (> 20 kft) Loops . . . . .	5-3
Figure 5-2	Line Circuit Test Arrangement . . . . .	5-6
Figure 5-3	Longitudinal Induction Test Circuit for Short (< 20 kft) Loops . . . . .	5-9
Figure 5-4	Example of Test Circuit Used for Testing ISDN for Longitudinal Induction Immunity Criteria . . . . .	5-14
Figure 5-5	Digital Subscriber Line (DSL) Test Arrangement . . . . .	5-15
Figure 5-6	Digital Loop Carrier (DLC) System, Between Remote Terminal (RT) and Customer End, Test Arrangement . . . . .	5-16
Figure 5-7	Longitudinal Induction Test Circuit for Trunk Circuits . . . . .	5-18
Figure 5-8	Analog Trunk Circuit Test Arrangement . . . . .	5-21
Figure 5-9	DLC System, Between RT and COT, Test Arrangement . . . . .	5-23
Figure 5-10	Longitudinal Induction Test Circuit for Cables . . . . .	5-24
Figure 5-11	Test Arrangement for Equipment Intended for Coaxial Cables . . . . .	5-25
Figure 7-1	Class A1 Voltage Limits (Sheet 1 of 2) . . . . .	7-5
Figure 7-2	Class A2 Voltage Limits (Sheet 1 of 2) . . . . .	7-8
Figure 7-3	Class A3 Voltage Limits (Sheet 1 of 2) . . . . .	7-11
Figure 7-4	Test Finger . . . . .	7-15
Figure 7-5	Interrupted/Tripped Criterion Defining the Duration for Which a Current of a Given Magnitude Is Allowed to Persist . . . . .	7-20
Figure 7-6	Test Circuit for Determining Volt-Amperes Characteristics . . . . .	7-21
Figure 9-1	Illustration of Three Options for Grounding an Output of Embedded DC Power Source . . . . .	9-11
Figure 9-2	Configuration of the DC Fault Test . . . . .	9-22
Figure 9-3	Configuration of the Proposed EFT Frame Test . . . . .	9-23
Figure 9-4	An Alternative Configuration for the EFT Test . . . . .	9-24
Figure 9-5	Laboratory Configuration for the Frame Surge Test . . . . .	9-25
Figure 9-6	In-Situ Configuration for the Frame Surge Test . . . . .	9-26
Figure 9-7	Laboratory Configuration of the EUT for the AC Fault Test . . . . .	9-27
Figure 9-8	In-Situ Configuration of the EUT for the AC Fault Test . . . . .	9-28
Figure A-1	Impulse Waveform . . . . .	A-1

## List of Tables

Table 3-1	Radiated Emission Requirement and Objective for Electric Fields . . . . .	3-5
Table 3-2	Radiated Emission Requirement for Electric Fields (Doors and Covers Open) . . . . .	3-8
Table 3-3	Conducted Emission Limits for AC Power Ports for Class A Equipment . . . . .	3-11
Table 3-4	Conducted Emission Limits for AC Power Ports for Class B Equipment . . . . .	3-11
Table 3-5	Conducted Emission Requirements for AC and DC Power Ports — Current . . . . .	3-12
Table 3-6	Conducted Emission Requirements for Signal Ports — Current . . . . .	3-12
Table 3-7	Metallic Voltage Limit on Analog Voiceband Leads . . . . .	3-14
Table 3-8	Longitudinal Voltage Limit on Analog Voiceband Leads . . . . .	3-14
Table 3-9	Longitudinal RMS Current Limits on Telecommunications Leads . . . . .	3-15
Table 3-10	Longitudinal Peak Current Limits on Telecommunications Leads . . . . .	3-15
Table 3-11	Conducted Immunity Requirements for Power Ports . . . . .	3-19
Table 3-12	Conducted Immunity Objectives for Voiceband and Telecommunications Leads . . . . .	3-20
Table 3-13	Instrumentation Bandwidths . . . . .	3-22
Table 3-14	1 to 10 GHz Immunity Scan Rate and Step Size . . . . .	3-51
Table 3-15	Frequencies of Key Interest . . . . .	3-52
Table 4-1	Test Connections of Telecommunications Port . . . . .	4-11
Table 4-2	First-Level Lightning Surge (Telecommunications Port) . . . . .	4-25
Table 4-3	Protection Test Criteria (Telecommunications Port) . . . . .	4-27
Table 4-4	Second-Level Lightning Surge (Telecommunications Port) . . . . .	4-30
Table 4-5	First-Level Intra-Building Lightning Surge for One- and Two-Pair Ports (Telecommunications Port) . . . . .	4-32
Table 4-6	First-Level Intra-Building Lightning Surge for Multi-Pair Ports (Telecommunications Port) . . . . .	4-33
Table 4-7	First-Level AC Power Fault (Telecommunications Port) . . . . .	4-38
Table 4-8	Second-Level AC Power Fault (Telecommunications Port) . . . . .	4-46
Table 4-9	Second-Level AC Power Fault for Equipment Ports With Secondary Protection (Telecommunications Port) . . . . .	4-48
Table 4-10	Second-Level AC Power Fault (Telecommunications Port) . . . . .	4-53
Table 4-11	Second-Level AC Power Fault for Equipment Ports With Secondary Protection (Telecommunications Port) . . . . .	4-55
Table 4-12	Protection Test Criteria for Equipment To Be Located on High-Exposure Customer Premises and OSP Facilities . . . . .	4-60
Table 4-13	Parameter Values Used for Equipment Intended for Agreed Primary Protection . . . . .	4-62
Table 4-14	Applicability of EIPP Requirements . . . . .	4-67
Table 4-15	Parameter Values Used for Equipment With Integrated Primary Protection . . . . .	4-69
Table 4-16	Fusing Coordination for Unprotected Circuits Suitable for Fusing . . . . .	4-73
Table 4-17	Fusing Coordination for Unprotected Circuits Not Acting as Fuse Links . . . . .	4-75
Table 4-18	AC Power Fault Immunity . . . . .	4-77
Table 4-19	Lightning Surges for Severe Climatic Conditions . . . . .	4-78



Table 4-20	Lightning Surges for Severe Climatic Conditions . . . . .	4-78
Table 4-21	First-Level Lightning Surge Test for Equipment Intended for Use Without an External Protector . . . . .	4-81
Table 4-22	First-Level AC Power Fault Test for Equipment Intended for Use Without an External Protector . . . . .	4-82
Table 4-23	Second-Level Lightning Surge Test for Equipment Intended for Use Without an External Protector . . . . .	4-83
Table 4-24	Second-Level AC Power Fault Test for Equipment Intended for Use Without an External Protector . . . . .	4-84
Table 4-25	First-Level Lightning Surge Test for Equipment Intended for Use With an External Protector . . . . .	4-85
Table 4-26	First-Level AC Power Fault Test for Equipment Intended for Use With an External Protector . . . . .	4-85
Table 4-27	Second-Level Lightning Surge Test for Equipment Intended for Use With an External Protector . . . . .	4-86
Table 4-28	Second-Level AC Power Fault Test for Equipment Intended for Use With an External Protector . . . . .	4-87
Table 4-29	First-Level Lightning Surge (Antenna Port) . . . . .	4-90
Table 4-30	First-Level Lightning Surge (AC Power Port) . . . . .	4-91
Table 4-31	Second-Level Lightning Surge (AC Power Port) . . . . .	4-91
Table 4-32	First-Level Lightning Surge (AC Power Port) . . . . .	4-92
Table 5-1	Longitudinal Induction Test Circuit Criteria for Long (> 20 kft) Loops . . . . .	5-4
Table 5-2	Longitudinal Induction Test Circuit Criteria for Short (< 20 kft) Loops . . . . .	5-10
Table 5-3	Longitudinal Induction Test Circuit Criteria for Trunks . . . . .	5-19
Table 5-4	Longitudinal Induction Test Circuit Criteria for Coaxial Cables . . . . .	5-24
Table 7-1	Values of Maximum Test Resistance . . . . .	7-4
Table 7-2	Accessibility to Continuous Class-A Voltages . . . . .	7-14
Table 9-1	Test Overcurrent Device Selection . . . . .	9-22
Table 9-2	Grounding Conductor Size for Fuse-Less Protector Block in the EUT . . . . .	9-29
Table 9-3	Grounding Conductor Size for Fused Protector Block in the EUT . . . . .	9-29
Table 10-1	Undervoltage Transient Waveform Characteristics (Figure 4 of ANSI T1.315-2001) . . . . .	10-3
Table 10-2	Overvoltage Transient Waveform Characteristics (Figure 3 of ANSI T1.315-2001) . . . . .	10-3
Table 10-3	Impulse Transient Waveform Characteristics (Figure 2 of ANSI T1.315-2001) . . . . .	10-4
Table A-1	Waveform Tolerances . . . . .	A-2
Table B-1	Applicable Criteria Set A for Network Equipment . . . . .	B-1
Table B-2	Applicable Criteria Set B for Network Equipment Ports . . . . .	B-1
Table B-3	Application Chart for Equipment Ports . . . . .	B-4



## Preface

### The Telcordia Technologies GR Process

Generic Requirements documents (GRs) provide the Telcordia Technologies view of proposed generic criteria for telecommunications equipment, systems, or services, and involve a wide variety of factors, including interoperability, network integrity, the expressed needs of industry members who have paid a fee to participate in the development of specific GRs, and other input.

The Telcordia GR process implements Telecommunications Act of 1996 directives relative to the development of industry-wide generic requirements relating to telecommunications equipment, including integral software and customer premises equipment. Pursuant to that Act, Telcordia invites members of the industry to participate in the development of GRs. Invitations to participate and the participation fees are published monthly in the *Telcordia Digest of Technical Information*, and posted on the Web, at <http://www.telcordia.com/digest>.

At the conclusion of the GR development process, Telcordia publishes the GR, which is available for license. The license fee entitles the licensee to receive that issue of the GR (GR-CORE) along with any Issues List Report (GR-ILR) and revisions, if any are released under that GR project. ILRs contain any technical issues that arise during GR development that Telcordia and the other participants would like further industry interaction on. The ILR may present issues for discussion, with or without proposed resolutions, and may describe proposed resolutions that lead to changes to the GR. Significant changes or additional material may be released as a revision to the GR-CORE.

Telcordia may also solicit general industry nonproprietary input regarding such GR material at the time of its publication, or through a special Industry Interaction Notice appearing in the *Telcordia Digest of Technical Information*. While unsolicited comments are welcome, any subsequent work by Telcordia regarding such comments will depend on participation in such GR work. Telcordia will acknowledge receipt of comments and will provide a status to the submitting company.

### About GR-1089-CORE

Issue 4 of GR-1089-CORE was developed jointly by Telcordia, telecommunications service providers, equipment manufacturers, and testing organizations. The participants for this reissue are as follows:

**Table 1** Participants of GR-1089 (Sheet 1 of 2)

<b>Company Participants</b>	<b>Company Representatives</b>	<b>Company Web Sites</b>
Adtran	Jim Wiese Dan Cassidy Jeff Whitmire Doug Parker, NCE Paul Stover, NCE	www.adtran.com
Alcatel	Tim Pantalis Charles Young Mike Shalla Stephane De Francesco Mamadou Kane Vito Scaringi Thong Vothang Lourdes Gasser Burr Wilson	www.alcatel.com
AT&T Services	Bon Pipkin Don Murray Mahmoud Elkenaney John Messina	https://ebiznet.sbc.com/ sbcnebs/
Bourns, Inc.	Michael Maytum	www.bourns.com
Calix Networks	Ted Lord	www.calix.com
Cisco Systems	John Krahnert Mark King Chuck Smith Chris Barsotti Greg Nix David A. Case	www.cisco.com
Commscope Solutions	Megan Heim	www.commscope.com
Fujitsu Network Communications	Corey Dayton	www.fujitsu.com/us
Fultec Semiconductor	Richard Harris Paul Wiener	www.fultec.com
Juniper Networks	Subbu Tallak John Lockwood	www.juniper.net
Littelfuse	Phillip B. Havens	www.littelfuse.com

**Table 1** Participants of GR-1089 (Sheet 2 of 2)

<b>Company Participants</b>	<b>Company Representatives</b>	<b>Company Web Sites</b>
Lucent Technologies	Hernan R. Noguchi William K. Hagmann Dheena Moongilan Joe Bordonaro Michael J. Downey Majid Safavi Raymond J. Johnson William H. Scofield Joseph Weisner Theodore M. Lach	www.lucent.com
National Technical Systems	Jim Press Steve Halme	www.ntscorp.com
Sun Microsystems	Lew Kurtz Jesus Olmedo	www.sun.com
Tellabs	Wes Atchison John Wise Danny Kinmbrough Todd Herman William Wong Sam Zurzolo	www.tellabs.com
Tyco Electronics	Al Martin Boris Golubovic Paul Becker	www.tycoelectronics.com
UTStarcom	Bill Stamos Mark Kohler Terrel Jones Scot Salzman Russ Panzarella Craig Mitchell	www.utstarcom.com
Verizon Services	James Giacchi L. C. Graff	www.verizonnebs.com
Verizon Wireless	John F. Lichtig, NCE Dan McMenamin	www.verizonwireless.com

## Relative Maturity Level, Status, and Plans

Telcordia considers this GR a mature document. Telcordia intends to maintain these criteria and update them as necessary.

## To Submit Comments

When submitting comments, please include the GR document number, and cite any pertinent section and requirement number. In responding to an ILR, please identify the pertinent Issue ID number. Please provide the name and address of the contact person in your company for further discussion.

Send comments to:

**Chrysanthos Chrysanthou**

Telcordia  
One Telcordia Drive, Room RRC-4D644  
Piscataway, NJ 08854-4182  
Phone: + 1.732.699.3357  
E-mail: cchrysan@telcordia.com

## To Request Telcordia Testing Services

Send requests for Telcordia Testing Services to:

**Richard Kluge, NEBS Director**

Telcordia  
One Telcordia Drive, Room RRC-4D660  
Piscataway, NJ 08854-4182  
Phone: + 1.732.699.5490  
E-mail: rkluge@telcordia.com

# 1 Introduction

## 1.1 Purpose and Scope

This Generic Requirements document (GR) presents the Telcordia and participating industry representatives view of proposed generic criteria covering Electromagnetic Compatibility (EMC) and electrical safety necessary for equipment to perform reliably and safely in a network environment of a typical telecommunication service provider. It places in a single reference document, EMC and electrical safety criteria for equipment used at COs; equipment placed in the Outside Plant (OSP) at such locations as Controlled Environmental Vaults (CEVs), Electronic Equipment Enclosures (EEEs), and huts; equipment located in uncontrolled structures, such as cabinets; and network equipment located at the customer premises.

Telecommunications equipment, by nature of its application in the telecommunications network, may be exposed to one or more sources of electromagnetic energy. The system-level generic criteria for EMC presented in the following sections are intended to help avoid equipment damage and malfunction because of lightning, 60-Hz commercial power fault conditions, Electrostatic Discharge (ESD), Electrical Fast Transient (EFT), Electromagnetic Interference (EMI), operation in the presence of a dc potential difference, and operation in a steady-state induced voltage environment. This document also presents other criteria intended to help establish that equipment will not become a fire or electrical safety hazard in the presence of severe lightning or 60-Hz commercial power fault conditions. Safe voltage levels for intentionally applied sources, electrochemical corrosion effects, grounding, and DC powering are considered as well.

This standard applies to wireless systems that provide fixed and/or mobile services that are installed in locations with telecommunications network equipment or information technology networking equipment and whose antennas are mounted outside the facility either on the roof or on an antenna mast. This standard is not applicable for evaluation of systems where the installation of the antenna is inside the facility or for portable handheld devices.

**NOTE:** The introduction of any wireless equipment to a network environment may require an on-site EMC assessment before installation of the wireless equipment in the network environment.

The following apply to specific interface ports of the network telecommunications equipment:

- EFT (Section 2)
- Conducted Emission and Immunity Criteria (Section 3)
- Lightning and AC Power Fault (Section 4)
- Steady-State Power Induction (Section 5)
- DC Potential Difference (Section 6)
- Corrosion (Section 8)
- DC Power Port of Telecommunications Load Equipment (Section 10).

Such interface ports are telecommunications, signal, coaxial cable, antenna, and power. Appendix B is to be used to determine the applicable criteria in these sections based on the equipment's intended physical location within the network (e.g., Central Office [COs]) remote sites, customer premises), its connection to the telecommunications network (e.g., OSP, intra-building), and the intended function of the interface ports. However, the

- Introduction (Section 1)
- ESD (Section 2)
- Radiated Emission and Immunity Criteria (Section 3)
- Electrical Safety Criteria (Section 7)
- Bonding and Grounding (Section 9)

apply to all network telecommunications equipment regardless of port type(s) that may be used in telecommunications facilities, as described above.

Other Telcordia GRs (e.g., Network Interface Devices [NIDs]) that may cover network equipment being investigated should be consulted for determining the applicable EMC and electrical safety criteria.

## 1.2 Items Not Covered in This GR

This document does not cover

- EMC and electrical safety criteria for transmission media (wire, cable, optical fiber cable, etc.), except insofar as they affect the EMC performance of the Equipment Under Test (EUT).
- Ancillary hardware used for electrical protection (carbon or gas tube surge protectors, ac surge protective devices, etc.).
- Equipment used in the specialized high-voltage environment of power stations and substations.
- Isolated ground planes (also known as an Isolated Bonding Network or IBN) are not covered. The criteria for Isolated Ground Planes are in GR-295-CORE, *Mesh and Isolated Bonding Networks: Definition and Applications to Telephone Central Offices*.<sup>[1]</sup>
- On-hook leakage resistance, loop dc resistance, loop input capacitance, and off-hook loop input impedance criteria that are covered in Sections 6 and 7 of FR-64, *LATA Switching Systems Generic Requirements (LSSGR)*.<sup>[2]</sup>

## 1.3 Requirements Terminology

The following requirements terminology is used throughout this document:

- **Requirement** — Feature or function that, in the view of Telcordia, is *necessary* to satisfy the needs of a typical client company. Failure to meet a requirement may cause application restrictions, result in improper functioning of the

product, or hinder operations. A Requirement contains the words *shall* or *must* and is flagged by the letter “**R**.”

- **Conditional Requirement** — Feature or function that, in the view of Telcordia, is *necessary in specific applications*. If a client company identifies a Conditional Requirement as necessary, it shall be treated as a requirement for the application(s). Conditions that may cause the Conditional Requirement to apply include, but are not limited to, certain client companies’ application environments, elements, or other requirements, etc. A Conditional Requirement is flagged by the letters “**CR**.”
- **Objective** — Feature or function that, in the view of Telcordia, is *desirable* and may be required by a client company. An Objective represents a goal to be achieved. An Objective may be reclassified as a Requirement at a specified date. An objective is flagged by the letter “**O**” and includes the words *it is desirable* or *it is an objective*.
- **Conditional Objective** — Feature or function that, in the view of Telcordia, is *desirable in specific applications* and may be required by a client company. It represents a goal to be achieved in the specified Condition(s). If a client company identifies a Conditional Objective as necessary, it shall be treated as a requirement for the application(s). A Conditional Objective is flagged by the letters “**CO**.”
- **Condition** — The circumstances that, in the view of Telcordia, will cause a Conditional Requirement or Conditional Objective to apply. A Condition is flagged by the letters “**Cn**.”

## 1.4 Requirement Labeling Conventions

As part of the Telcordia GR Process, proposed requirements and objectives are labeled using conventions that are explained in the following two sections.

### 1.4.1 Numbering of Requirement and Related Objects

Each Requirement, Objective, Condition, Conditional Requirement, and Conditional Objective object is identified by both a local and an absolute number. The local number consists of the object's document section number and its sequence number in the section (e.g., **R3-1** is the first Requirement in Section 3). The local number appears in the margin to the left of the Requirement. A Requirement object's local number may change in subsequent issues of a document if other Requirements are added to the section or deleted.

The absolute number is a permanently assigned number that will remain for the life of the Requirement; it will not change with new issues of the document. The absolute number is presented in brackets (e.g., [**2**]) at the beginning of the requirement text.

Neither the local nor the absolute number of a Conditional Requirement or Conditional Objective depends on the number of the related Condition(s). If there is any ambiguity about which Conditions apply, the specific Condition(s) will be referred to by number in the text of the Conditional Requirement or Conditional Objective.

References to Requirements, Objectives, or Conditions published in other Generic Requirements documents will include both the document number and the Requirement object's absolute number. For example, **R2345-12** refers to Requirement [12] in GR-2345-CORE.

#### 1.4.2 Requirement, Conditional Requirement, and Objective Identification

A Requirement object may have numerous elements (paragraphs, lists, tables, equations, etc.). To aid the reader in identifying each part of the requirement, rules are used above and below requirement content.

Introductory information.

---

---

Content of Requirement object(s).

---

---

### 1.5 Organization

Exclusive of the Introduction, this document consists of nine additional sections (Sections 2 through 10), each covering a separate aspect of EMC, electrical safety, and corrosion. There are also five appendixes. The sections and appendixes are:

- Section 2, *System-Level Electrostatic Discharge (ESD) and Electrical Fast Transient (EFT)*, discusses system-level ESD and EFT immunity criteria, as well as their test methods.
- Section 3, *Electromagnetic Interference*, presents EMI immunity and emissions criteria for equipment located in telecommunications facilities, as well as network equipment located at customers' premises.
- Section 4, *Lightning and AC Power Fault*, discusses voltages and currents that may occur in a telecommunications network as a result of the effects of lightning and ac power faults. Criteria intended to establish equipment immunity to damage and malfunction from lightning and ac power faults are presented. This section also contains criteria intended to establish that equipment will not become a fire or electrical safety hazard under severe lightning or ac power fault conditions.
- Section 5, *Steady-State Power Induction*, contains criteria intended to ensure that equipment will function in the presence of steady-state ac power induction that may be encountered in a telecommunications network.
- Section 6, *DC Potential Difference*, characterizes the dc potential difference that may exist between equipment locations, such as between a CO and a remote terminal. Equipment is expected to perform properly in the presence of differences in dc potential.



- Section 7, *Electrical Safety Criteria*, is concerned with the safety of personnel who must access the equipment, either in normal use or for maintenance and repair. Criteria for intentionally applied continuous source voltage, duration-limited voltages such as ringing, and leakage currents from exposed surfaces of the equipment are contained in this section. Considerations for listing network equipment by a Nationally Recognized Testing Laboratory (NRTL) are also included.
- Section 8, *Corrosion*, is concerned with minimizing corrosion of the OSP by specifying the polarity and magnitude of continuous DC voltages applied by network equipment.
- Section 9, *Bonding and Grounding*, describes the requirements for bonding and grounding systems and defines Isolated Bonding Network (IBN) and Common Bonding Network (CBN) configurations. It presents bonding and grounding criteria for dc power systems, ac-powered equipment, and telecommunications equipment. Criteria for bonding and grounding conductors and connectors are also covered. Short-circuit tests are described. Additional criteria are presented to establish the compatibility of equipment traditionally installed in an IBN, but now intended for installation with multiple intentional or incidental connections to the CBN.
- Section 10, *DC Power Port of Telecommunications Load Equipment*, provides criteria for the dc power port of telecommunications equipment that is powered from a shared dc power plant.
- Appendix A defines a double-exponential impulse waveform of duration A/B seconds.
- Appendix B serves as a guide to aid the reader in the application of the tests contained herein to the various port types of telecommunications equipment covered.
- Appendix C provides the references used in this document.
- Appendix D provides definitions of terms used in this document.
- Appendix E provides definitions of acronyms.
- A Requirement-Object Index (ROI) lists the requirements and their associated page numbers throughout this GR.

## 1.6 Reasons for GR-1089-CORE, Issue 4

### CAUTION

**CAUTION!** This issue of GR contains new criteria, extensive structural revisions and clarifications in test procedures. Readers are urged to review this GR carefully.

The following changes have occurred in GR-1089-CORE since Issue 3 was last published by Telcordia in October 2002:

- Included appropriate criteria for wireless systems
- Added a new appendix that provides definitions of terms used in this document
- Clarified performance criteria and test procedures where necessary.

- Section 1, *Introduction*
  - Included guidelines on equipment evaluation
  - Added generic criteria on equipment documentation including root cause analysis.
- Section 2, *System-Level Electrostatic Discharge (ESD)*
  - Extended date on which ESD installation and repair objective becomes a requirement
  - Revised the requirements on ESD Warning Labels
  - Established date on which EFT objectives become requirements.
- Section 3, *Electromagnetic Interference*
  - Adopted the new FCC Part 15 requirements on emission for ac power lines
  - Revised the conducted emissions and immunity criteria for dc power ports
  - Revised the conducted emissions and immunity criteria for broadband leads including the test procedure.
- Section 4, *Lightning and AC Power Fault Resistibility*
  - Clarified procedures for calibration of generators
  - Revised test conditions for equipment with 4-wire and multi-wire interfaces
  - Modified the number of samples to be tested for second-level tests
  - Added intra-building criteria for equipment with multi-wire interfaces
  - Added intra-building criteria for equipment connected to shielded cables, communications and coaxial
  - Revised second-level tests as applied to equipment with secondary protection
  - Added surge testing methods for equipment that delivers power over communications wiring, to be performed under normal operation
  - Revised the protection coordination tests
  - Established new equipment port for equipment located at remote sites and specified the appropriate criteria
  - Added a new subsection that provides appropriate criteria for equipment with agreed primary protection
  - Added a new subsection that provides appropriate criteria for equipment with integrated primary protection
  - Revised lightning criteria for equipment with ac power ports
  - Added surge criteria for dc power ports for equipment located at OSP facilities.
- Section 7, *Electrical Safety Criteria*
  - Revised test procedure for classifying the source limits

- Revised the powering limitation criteria to include new methods for powering network equipment remotely.
- Section 9, *Bonding and Grounding*
  - Revised the grounding requirements of embedded power sources greater than 150 VA for specific applications.
- Added a new Section 10, *DC Power Port of Telecommunications Load Equipment*, that provides criteria on dc power ports of telecommunications equipment, which are powered from a shared dc power plant.

The new requirements for Issue 4 begin at the number [153]. This document completely replaces all previous issues of this GR.

### 1.6.1 Reasons for GR-1089-CORE, Issue 3

The main reasons for GR-1089-CORE, Issue 3, were to:

- Section 2, *System-Level Electrostatic Discharge (ESD)*
  - Harmonize with the most recent revisions to the international test criteria and methods of IEC 61000-4-2,<sup>[7]</sup> the definitive standard for system-level ESD immunity of electronic equipment.
  - Add *Electrical Fast Transients (EFT)* criteria on telecommunications and power ports of equipment in accordance with IEC 61000-4-4.<sup>[10]</sup>
- Section 3, *Electromagnetic Interference*
  - Add conducted emissions and immunity criteria at broadband frequencies.
  - Address the new FCC Part 15 requirements on emission for ac power lines.
- Section 4, *Lightning and AC Power Fault Resistibility*
  - Add a conditional requirement and objective to address the application of external current limiters in high-speed digital networks.
  - Add an objective to address coordination of secondary protection of equipment with the primary protection.
  - Convert first-level power fault tests 6, 7, 8, and 9 from objectives to requirements.
  - Define a procedure for determining the proper voltages and currents to be applied to equipment containing secondary protectors during the lightning and ac power fault tests.
  - Clarify the number of samples to be tested to each test, and for multi-port equipment, the number of ports to be tested.
  - Modify the test procedure for current-limiting protector tests.
  - Revise the criteria for second-level power fault tests for equipment located at customer premises.
  - Clarify the test procedure for first-level tests.
  - Relocate all listing requirements to Section 7.

- Section 5, *Steady-State Power Induction*
  - Add criteria for coaxial port immunity to steady-state power induction.
- Section 7, *Electrical Safety Criteria*
  - Harmonize, where possible, electrical safety terminology with international and North American telecommunications safety standards.
- Section 9, *Bonding and Grounding*
  - Provide guidance on the application of the criteria to various types of network equipment.
  - Add criteria for bonding of parts and circuit packs.
  - Modify the short-circuit tests.
- Clarify the number of samples required to be tested in each section.
- Provide test procedures related to non-switching systems where necessary.
- Clarify test procedures where necessary.
- Provide clarification and editorial changes to resolve comments from the industry.
- Re-arrange paragraphs for a clearer flow. Where applicable, the criteria for telecommunications ports, coaxial ports and power ports are addressed separately.

## 1.7 Application of This Document

The manufacturer shall, at a minimum, meet its own design standards and design engineering requirements, and all requirements imposed by law. Manufacturing requirements, manufacturing and workmanship standards, and the use of accepted commercial practices supplement the manufacturer's design and engineering criteria, and shall also be met when relevant to product integrity, performance, and reliability.

Product integrity shall be maintained, and there shall be no deviations from physical criteria that may or will adversely affect the product with respect to safety, reliability, interchangeability, life, performance and operation, quality, protective chemical sprays, maintenance, or aesthetics. The manufacturer shall make any proposal to the telecommunications company that will improve the product with respect to safety, reliability, interchangeability, life, performance and operation, quality, protective chemical sprays, maintenance, or aesthetics.

Acceptance of nonconforming products is not the subject of this document. Such decisions are made by the telecommunications company or its designated representative. The manufacturer shall propose to the telecommunications company any alternatives, deviations, or modifications to its product necessitated by site-specific conditions or other factors.

Products shall be manufactured in accordance with the applicable requirements identified by:

- Federal Communications Commission (FCC)

- National Electrical Code (NEC)
- National Electrical Safety Code (NESC)
- Department of Labor—Occupational Safety and Health Administration (OSHA)
- All other applicable federal, state, and local requirements including, but not limited to, statutes, rules, regulations, orders, or ordinances, or as otherwise imposed by law.

Where requirements are not stated in this document, in contractual technical requirements, or in other applicable documents, the manufacturer's requirements consistent with industry standards shall be met.

Because of the complexity and variety of technologies used in network telecommunications equipment, the criteria of this document cover a wide range of application conditions. Engineering investigation or evaluation of a particular type of equipment may indicate that the specific technology causes certain tests to be unnecessary. In addition, network telecommunications equipment should be performing its design-intended functions, when determining conformance to performance criteria. For example, switching systems may be tested to operating states such as on-hook, off-hook and ringing while digital systems may be tested to bit error rate. The performance criteria shall be in accordance with applicable Telcordia Generic Requirements, national and international standards. The decision of applicable tests to be performed and functions for determining performance criteria shall be mutually agreed to between manufacturer and telecommunications company, or representatives of telecommunications companies. These decisions would be incorporated in a test plan mutually agreed to between manufacturer and telecommunications company or testing laboratory.

## 1.8 Guidelines for Equipment Evaluation

In general, newly-designed systems and associated subassemblies shall be evaluated against the criteria of this issue. Existing systems and subassemblies (legacy) that have been evaluated and conform to a previous issue of GR-1089-CORE and that have supporting evidence of such evaluations, do not need to be re-evaluated for this reissue. Modified or new subassemblies (e.g, line cards, circuit packs, etc.) intended for systems evaluated using criteria from an earlier issue of GR-1089-CORE shall be evaluated using the criteria of this issue and shall conform to the requirements of GR-209-CORE, *Generic Requirements for Product Change Notices (PCNs)*.<sup>[3]</sup>

Where the legacy system does not meet a requirement in this reissue of GR-1089-CORE, it may not be possible to evaluate the conformance of the modified or new subassembly against the current requirement. In this case, it shall be demonstrated that the new equipment installed in the legacy system does not prevent the system from meeting the original level of conformance.

## 1.9 Documentation

### 1.9.1 General

- R1-1** [153] The test report for each section **shall** clearly identify the type of each equipment port evaluated in accordance with [Appendix B](#).
- R1-2** [154] Cautions, Warnings and other pertinent information specified in the following criteria of this GR **shall** be contained in the EUT's test report:  
**R2-5** [5], **R2-6** [6], **R2-7** [7], **R4-13** [31], **R4-20** [34], **R4-36** [41], **R7-16** [63], **R9-3** [76], **R9-10** [79], **R4-78** [107], **R4-83** [112], **CR4-21** [135], **R9-16** [151], **R1-3** [155], **R3-1** [159], **R4-16** [171], **CO4-37** [178], **R4-39** [180], **R4-40** [181], **R4-42** [183], **R4-49** [190], **R4-50** [191], **R4-85** [208], **R4-88** [209], **R4-89** [210], **R9-6** [213], **O10-2** [219].
- R1-3** [155] Cautions, Warnings and other pertinent information specified in criteria in this GR **shall** be contained in the installation and maintenance documentation and **shall** be provided in printed form with the equipment. CDs, DVDs, URLs, and other electronic media are not acceptable for disseminating the documentation requirements contained in this GR; however, they may be included in addition to the printed information.
- R1-4** [156] If it is evident from the design and construction of the equipment that a particular test is not applicable, the test is not required to be performed. The report **shall** include a clear explanation of the reasons why the test(s) was not performed.

### 1.9.2 Root Cause Analysis

Compliance to the criteria in this document is critical to evaluating the suitability of equipment for use in the telecommunication network. Hence, the equipment users require that the equipment manufacturers understand and correct known deficiencies.

- R1-5** [157] The equipment manufacturer **shall** be responsible to perform a Root Cause Analysis (RCA) for each failure that occurs during GR-1089 product testing, even if subsequent re-testing is successful.
- R1-6** [158] The resolution to the RCA **shall** be consistent with customers' Reliability/technical Requirements. RCAs **shall** include an explanation of what failed, why it failed (i.e., what caused the failure), and a corrective action description. When available, manufacturing cut-in dates, serial numbers, product ID changes, ordering requirements, availability, etc., for equipment incorporating the corrective action **shall** be included in RCAs.

## 1.10 Number of Samples To Be Tested

One sample of EUT shall be tested in Section 2, Section 3, Section 6, Section 7, Section 8, Section 9, and Section 10. The number of test samples for Sections 4 and 5 are provided in these sections, respectively.

The tests shall be performed on representative samples of equipment with the objective of determining if the equipment, as designed and manufactured, conforms to the criteria of this GR.

## 1.11 Relation to Other Telcordia Documents

This document is related to the following Telcordia generic requirements documents:

- LSSGR — GR-1089-CORE is Section 15 of FR-64,<sup>[2]</sup> *LATA Switching Systems Generic Requirements (LSSGR)*.
- TSGR — GR-1089-CORE is a module of FR-440,<sup>[4]</sup> *Transport Systems Generic Requirements (TSGR)*.
- NEBSFR — GR-1089-CORE is a module of FR-2063,<sup>[5]</sup> *Network Equipment-Building Systems (NEBS™) Family of Requirements (NEBSFR)*.





## 2 System-Level Electrostatic Discharge (ESD) and Electrical Fast Transient (EFT)

### 2.1 System-Level Electrostatic Discharge (ESD)

#### 2.1.1 Overview

Discharge of electrostatic voltages on or near equipment assemblies can be a significant cause of failures or malfunctions. Equipment is susceptible to ESD effects at all stages of storage, installation, testing, operation, adjustment, and maintenance. Failures or malfunctions occur when the effects of ESD

- Extend to the device level and cause device damage
- Alter the system software or firmware, affecting equipment functional performance
- Interfere with stored or transmitted information or data, resulting in malfunction and system errors.

The requirements and objectives for immunity to ESD apply to equipment used in Central Offices (COs), equipment located at remote terminals such as may be found in Electronic Equipment Enclosures (EEEs) or other field installations, and network equipment located on customers' premises.

Circuit packs, as covered in this document, are tested for ESD immunity at the system level only (for example, discharges applied to faceplate and ejector tab of installed packs) as an integral part of the equipment or system under test. Electrostatic discharge immunity criteria for circuit packs, as stand-alone assemblies, are contained in GR-78-CORE, *Generic Requirements for the Physical Design and Manufacture of Telecommunications Products and Equipment*.<sup>[6]</sup>

#### 2.1.2 ESD Immunity Criteria

ESD immunity criteria are presented for normal equipment operation and for installation and maintenance. Under normal operation, discharges are applied to those points and surfaces that are accessible to personnel during the normal operation of the equipment (see [Section 2.1.4.3](#) and [Section 2.1.4.3.1](#)). Under installation and maintenance conditions, discharges are applied to those points and surfaces that are accessible to personnel installing the equipment or performing maintenance operations (see [Section 2.1.4.3](#) and [Section 2.1.4.3.2](#)). The immunity criteria for installation and maintenance are intended to minimize the need for special ESD mitigative procedures by installation and maintenance personnel in uncontrolled environments.

---

**R2-1** [1]The Equipment Under Test (EUT) **shall** be tested using the methods of International Standard IEC 61000-4-2.<sup>[7]</sup>

**R2-2** [2]The EUT **shall** be tested to both the immunity criteria for normal operation and to the immunity criteria for installation and maintenance.

The preferred method of ESD immunity testing is the contact discharge method. Contact discharges are applied to conductive surfaces and to coupling planes; air discharges are applied to insulating surfaces. It is not generally permitted to mix contact and air discharges when testing to conductive surfaces.

#### 2.1.2.1 Immunity Criteria — Normal Operation

**R2-3** [3] The EUT **shall not** be damaged and **shall** continue to operate without service-affecting responses or need for manual intervention, as defined in [Section 2.1.3](#), when subjected to 10 discharges of each polarity, both positive and negative, at Test Level 2 (4 kV) and Test Level 4 (15 kV) for air discharges, **or** at Test Level 4 (8 kV) for contact discharges, of IEC 61000-4-2, Clause 5. A total of 40 air discharges or 20 contact discharges **shall** be applied to each test point selected in accordance with [Section 2.1.4.3](#) and [Section 2.1.4.3.1](#). The test procedure of IEC 61000-4-2, Clause 8 **shall** be used (see [Section 2.1.4](#)).

#### 2.1.2.2 Immunity Criteria — Installation and Maintenance

**O2-4** [4]This objective will become a requirement effective January 1, 2008. The EUT **should not** be damaged and **should** continue to operate without service-affecting responses or need for manual intervention, as defined in [Section 2.1.3](#), when subjected to 10 discharges of each polarity, both positive and negative, at Test Level 2 (4 kV) and Test Level 4 (15 kV) for air discharges, **or** at Test Level 4 (8 kV) for contact discharges, of IEC 61000-4-2, Clause 5. A total of 40 air discharges **or** 20 contact discharges **should** be applied to each test point selected in accordance with [Section 2.1.4.3](#) and [Section 2.1.4.3.2](#). The test procedure of IEC 61000-4-2, Clause 8, **should** be used (see [Section 2.1.4](#)).

#### 2.1.2.3 ESD Warning Label Requirements

**R2-5** [5]Equipment that could be static sensitive **shall** have ESD labeling on the front of the equipment in accordance with EIA-471-1996, *Symbol and Label for Electrostatic Sensitive Devices*.<sup>[8]</sup> If the ESD labeling cannot be located on the front of the equipment, it should be located in another visible location. In addition, the documentation for this type of equipment **shall** indicate ESD sensitivity, and contain cautions that ESD mitigative procedures, such as wearing wriststraps, be used during installation and maintenance.

## 2.1.2.4 Equipment-Specific Requirements

### 2.1.2.4.1 Additional Equipment Requirements

**R2-6** [6] Any additional equipment requirements such as special site preparation, restrictions on the air conditioning, relative humidity control, or the choice of static dissipating materials for furniture or flooring **shall** be specified in the product documentation.

### 2.1.2.4.2 Maintenance Information

**R2-7** [7] Any maintenance information supplied to field personnel **shall** contain explicit warnings concerning any procedures that are to be followed to prevent ESD events when handling the equipment (e.g., use of wriststraps). Any warnings to use only static dissipating materials **shall** appear, as appropriate, in the descriptive documentation.

## 2.1.3 Service-Affecting Responses and Manual Interventions

Services-affecting responses and manual intervention are those events that are considered to noticeably degrade service, cause loss of data, or require manual intervention by service personnel or customers. Examples of service-affecting responses include, but are not limited to, loss of established calls, loss of calls in progress, loss or corruption of stored data, synchronization errors, bit and data errors exceeding a permitted threshold as specified in the EUT performance criteria. The EUT performance criteria for evaluating service-affecting responses are specified in the applicable Telcordia Generic Requirements, national standards and international standards, or in an agreement between the manufacturer and the user. The test report shall

- Specify the performance criteria and its associated documentation
- Record service-affecting responses and manual interventions observed during the sequence of test discharges.

Manual intervention is considered to have occurred when it becomes necessary to physically interact with the equipment to restore normal operation, such as when clearing alarms, resetting circuit breakers, replacing fuses, or typing a command at a control console.

## 2.1.4 ESD Test Methods and Procedures

ESD tests shall be conducted in accordance with International Standard IEC 61000-4-2, Clauses 7 and 8. The test arrangement specified in IEC 61000-4-2, Clause 7, for tests performed in laboratories is the preferred method. Discharges shall be applied in both positive and negative voltage polarities.



#### 2.1.4.1 Test Methods — Normal Operation

Where the EUT contains panels and/or doors, normal operation testing shall first be performed with all the panels in place and the doors closed. Where the EUT contains large nonconductive surfaces such as plastic doors or panels to which the ESD test set will not discharge, discharges are to be applied to the horizontal (where appropriate) and vertical coupling planes, as discussed in IEC 61000-4-2, Clause 8.

Doors shall then be opened to discharge to door edges and inner door surfaces. Also, where the EUT contains removable panels, all of those panels shall be removed and set aside, and discharges shall be applied to the horizontal (where appropriate) and vertical coupling planes as discussed in IEC 61000-4-2, Clause 8. Where user-accessed components, such as control panels and cabinets of tape- and disk-drive units, and wriststrap jacks are present behind doors or panels, they shall be tested when the doors are opened or the panels removed.

Ten (10) discharges of each polarity, both positive and negative, are to be applied to each coupling plane in each of four (4) positions so that the four (4) faces of the EUT are completely illuminated.

#### 2.1.4.2 Test Methods — Installation and Maintenance

When equipment contains panels and/or doors, installation and maintenance testing is performed with all panels removed and doors opened.

#### 2.1.4.3 Selection of Test Points

Examples of test points to which discharges shall be applied include panels, doors, and exposed structural frame areas on equipment assemblies; consoles and terminals; pushbuttons; keyboards; keypads; circuit-pack faceplates and extractor tabs; lamps and light-emitting diodes; circuit breakers; accessible fuses and fuse holders; switches; wriststrap jacks; sockets designed for metallic plugs such as telephone jacks; metallic covers of D-subminiature connectors; and test-plug receptacles.

Sockets, jacks, connectors, and other receptacles identified as test points should be equipped with their mating connectors or cables, if that is the normal mode of operation, and tested by the application of discharges to exposed surfaces. Where sockets, jacks, connectors, and other receptacles are not normally equipped with their mating connectors or cables, the tip of the ESD test gun should not be inserted in holes or recessed areas in an attempt to force a discharge to recessed pins.

Antenna ports, wiring backplanes and any other intentionally exposed wiring on equipment are not expected to meet the ESD immunity criteria. Test points should not be assigned to these items. Additional guidance for selection of test points is provided in IEC 61000-4-2, Clause 8.

#### 2.1.4.3.1 Test Points — Normal Operation

Test points selected shall include all surfaces that may be contacted during the normal operation of the equipment. Test points shall include (but not be limited to) wriststrap jacks, any area near a wriststrap jack that personnel may inadvertently contact while connecting the wriststrap, user-accessed components such as tape and disk drives, outer surfaces of doors and panels enclosing the EUT, edges and inner surfaces of doors (at least 2 inches from the hinge axis), and normally exposed equipment frames and shelves. The test report shall list all test points that are selected for normal operation.

#### 2.1.4.3.2 Test Points — Installation and Maintenance

Test points selected shall include all surfaces that may be contacted during the installation and maintenance of the equipment. See IEC 61000-4-2, Section 8.3.1, for additional guidance on the selection of test points. Test points shall include (but not be limited to) equipment frames and shelves that are behind closed doors or panels, faceplates and extractor tabs of circuit packs, switches, fuses, jacks, and any other surface likely to be touched by installation and maintenance personnel. The test report shall list all test points that are selected for installation and maintenance.

#### 2.1.4.4 EUT Operating Conditions

ESD tests shall be performed on fully operational, suitably configured, and typically loaded production equipment, containing all necessary hardware, software, and firmware, for its intended application. The EUT shall demonstrate its ability to perform its normal operation before, during, and after electrostatic discharges are applied, so that both immunity to malfunction and immunity to damage may be established. The use of special software and firmware is permitted if the EUT demonstrates that it is configured, installed, and operated in a manner that is consistent with its normal operation.

For example, a switching system should be loaded as follows during ESD testing:

- If the EUT principally performs call processing, then traffic should be simulated by the use of “load boxes” with a sufficient number of originating and terminating lines and trunks to generate a nominal traffic load equivalent to 50% of the rated call processing capacity of the EUT. A load box is a device that generates actual physical calls on the line and trunk ports of the EUT, exercising all the resources of the EUT that would be used for live traffic. An appropriate call mix (such as dial pulse and dual-tone multifrequency) as given in GR-517-CORE, *LSSGR Section 17: Traffic Capacity and Environment*,<sup>[9]</sup> is to be carried by the EUT.
- When the EUT is a distributed processing system composed of both central and peripheral processing subsystems, the test load level applies only to the portion of the EUT affected by the particular test. Portions of the EUT that are judged to be unaffected by a particular test may be operated at lower load levels for that test. However, all units should be loaded to some extent.



- For high-capacity processing systems, it may be impractical to bring the load on the EUT up to the prescribed level solely with the use of load boxes. In such cases, it is acceptable to provide additional traffic using internal traffic simulation software or other artificial means to increase the call processing load to the prescribed level. However, a minimum of 6000 calls per hour should be provided by the use of load boxes. The capability to detect and report call processing errors in the artificial traffic must be comparable to that for traffic generated by the use of load boxes.
- Other switching system functions such as data transfer, maintenance routines, and Automatic Message Accounting (AMA) should also be ongoing during the ESD testing.

For systems other than switching systems, the EUT shall be configured, installed, and operated in a manner that is consistent with typical applications.

For example, a disk drive or solid-state memory unit shall be reading, writing, and transferring data, and performing any other normal operation functions during the tests.

The test program or other means of exercising the equipment shall ensure that the various parts of a system are exercised in a manner that permits detection of all system disturbances during ESD testing.

All connections and leads on the EUT that may in normal operation provide a path to ground for static discharge currents shall be appropriately terminated.

#### 2.1.4.5 ESD Test Site

The ESD test site shall be sufficiently large to minimize test variability caused by the proximity of other equipment or structures. A minimum clear-area radius of 1 meter shall be provided between the EUT and other metallic structures and walls. A shielded room used as the test site should be lined with radiation-absorbing material (that is, it should be an anechoic or semi-anechoic chamber), or it should provide a minimum 1-meter clearance between the EUT and conducting surfaces other than the floor. Where ESD tests must be performed in the field and a minimum clear-area radius of 1 meter cannot be maintained, the clear-area radius should be made as large as possible.

## 2.2 Electrical Fast Transient (EFT)

The EFT tests should be conducted in accordance with the international standard IEC 61000-4-4.<sup>[10]</sup>

**02-8 [126]** This objective will become a requirement effective January 1, 2008. The EUT **should** not be damaged and **should** continue to operate without service-affecting responses or the need for manual intervention, as defined in [Section 2.1.3](#), when 5 1-minute EFT/Burst applications of each polarity, positive and negative, are applied with 5-kHz repetition frequency at:

- 0.25 kV for Port Types 1 and 2 as defined in [Appendix B](#)

- 0.5 kV for AC and DC Ports of network equipment to be located in non-customer premises
  - 0.5 kV for Port Types 3 and 4 as defined in [Appendix B](#)
  - 1 kV for AC and DC Ports of equipment to be located in customer premises.
- 

### 2.2.1 EFT Test Methods and Procedures

EFT tests should be conducted in accordance with International Standard IEC 61000-4-4,<sup>[10]</sup> Clauses 6, 7, and 8. The capacitive coupling clamp specified in Clause 6.3 of IEC 61000-4-4<sup>[10]</sup> is the preferred method for EFT testing. The test arrangement specified in IEC 61000-4-4,<sup>[10]</sup> Clause 7, for tests performed in laboratories is the preferred method.

If Bit Error Rate (BER) measuring equipment or other auxiliary equipment is used to verify EUT performance, the measuring or auxiliary equipment must be capable of withstanding the EFT/Burst application.

EFT tests should be performed on fully operational, suitably configured, and typically loaded production equipment, containing all necessary hardware, software, and firmware, for its intended application. The EUT should demonstrate its ability to perform its normal operation before, during, and after the 1-minute EFT/Burst application is applied. The use of special software and firmware is permitted if the EUT demonstrates that is configured, installed, and operated in a manner that is consistent with its normal operation. Tests are applied where the relevant ports exist.





## 3 Electromagnetic Interference

### 3.1 General

#### 3.1.1 Overview

This section provides the Electromagnetic Interference (EMI) generic criteria and the associated measurement procedures for intentional and unintentional radiators, referred to as Equipment Under Test (EUT) throughout this section. These generic criteria for EMI are established so that the following goals may be accomplished:

- An EUT complies with the specifications of Part 15 of the Federal Communications Commission (FCC) Rules<sup>[11]</sup>
- An EUT complies with Part 68 of the Federal Communications Commission (FCC) Rules<sup>[12]</sup> and the technical criteria established in ANSI/TIA-968-A-2002<sup>[13]</sup>, *Telecommunications - Telephone Terminal Equipment - Technical Requirements for Connection of Terminal Equipment to the Telephone Network*
- An EUT has intrasystem Electromagnetic Compatibility (EMC) with other equipment located within the same facility
- Intersystem EMC exists between an EUT and other electronic equipment in the surrounding environment.

Because the latter two goals are beyond the scope of the FCC rules, the criteria contained in this section include limits on radiated and conducted noise emissions from a system, and levels of radiated and conducted noise to which the system should be immune. Methods for measurement of the emission and immunity levels are also covered.

Intentional radiators may have to meet other applicable FCC specifications in addition to those specified in this GR. The EUT shall obtain FCC certification to the applicable FCC parts in 47 CFR (Code of Federal Regulations). The criteria apply to wireless systems that provide fixed and/or mobile services that are installed in locations with telecommunications network equipment or information technology networking equipment and whose antennas are mounted outside the facility either on the roof or on an antenna mast (see Type 6 port in [Appendix B](#)).

#### 3.1.2 Intent of EMI Criteria

The radiated emission criteria provided for intentional and unintentional radiators, and the conducted emission criteria provided for ac power ports are predominantly the radio noise emission limits specified by the FCC for Class-A or Class-B digital devices. The frequency range of the radiated emissions criteria is expanded to avoid interference with nearby telecommunications terminals. Immunity criteria are specified to avoid interference to equipment from intentional transmitters and from unintentional Radio-Frequency (RF) energy sources.

The criteria for immunity are to minimize interference to equipment located near licensed transmitters (within approximately 3 kilometers [km] from high-powered transmitters or in facilities where hand-held transmitters are permitted). The criteria also provide additional margin against interference from noncompliant equipment that may be nearby, and from spurious emissions from portable tools, appliances, welding equipment, etc.

Conducted emission criteria on telecommunications leads are intended to prevent unintended signals transmitted from equipment at frequencies above voiceband from interfering with telecommunications transmission systems or other services that operate at such frequencies.

Compliance with the radiated and conducted emission criteria should be determined in accordance with the appropriate measurement procedures given in [Section 3.4](#). Verification of compliance with the radiated and conducted immunity criteria should be determined in accordance with the appropriate measurement procedures given in [Section 3.5](#).

### 3.1.3 FCC Part 15 Criteria

The FCC specifies limits on radiated and conducted radio noise emissions from digital devices in Subpart B of Part 15 of the FCC Rules.<sup>[11]</sup> A digital device is defined as an *unintentional radiator (device or system) that generates and uses timing signals or pulses at a rate in excess of 9,000 pulses (cycles) per second and uses digital techniques; inclusive of telephone equipment that uses digital techniques or any device or system that generates and uses radio frequency energy for the purpose of performing data processing functions, such as electronic computations, operations, transformations, recording, filing, sorting, storage, retrieval, or transfer.*

The FCC defines a Class-A digital device as one *marketed for use in a commercial, industrial or business environment, exclusive of a device that is marketed for use by the general public or is intended to be used in the home.* Most equipment located in dedicated telephone company premises should be considered to be Class-A digital devices and shall meet all requirements specified by the FCC for such devices. Over the FCC frequency range, the emission limits in this GR are the same as those specified by the FCC. The FCC defines a Class-B digital device as one *marketed for use in a residential environment notwithstanding use in commercial, business and industrial environments.* These include personal computers, calculators, and similar electronic devices for use by the general public.

Because the general public typically has receivers (AM, FM, TV) in close proximity to digital devices, Class B emission limits are more restrictive than Class A. The FCC further notes that *the responsible party may also qualify a device intended to be marketed in a commercial, business or industrial environment as a Class-B device, and in fact is encouraged to do so, provided the device complies with the technical specifications for a Class-B digital device.* If equipment repeatedly causes interference to radio communications, the FCC may classify it as a Class-B digital device, regardless of its intended use. Accordingly, equipment must be classified as either a Class-A or Class-B digital device and shall meet all the requirements specified by the FCC for such a device.

Under Section 15.103(b) of the FCC Rules, *a digital device used exclusively as an electronic control or power system utilized by a public utility or in an industrial plant* is considered exempt from complying with the technical and labeling requirements of the FCC for digital devices. However, *the term public utility includes equipment only to the extent that it is in a dedicated building or large room owned or leased by the utility and does not extend to equipment installed in a subscriber's facility.* The digital device is subject to the general conditions of operation in Sections 15.5 and 15.29 of the FCC Rules.

The FCC also states: *The operator of the exempted device shall be required to stop operating the device upon a finding by the [Federal Communications] Commission or its representative that the device is causing harmful interference. Operation shall not resume until the condition causing harmful interference has been corrected. Although not mandatory, it is strongly recommended that the manufacturer of an exempted device endeavor to have the device meet the specific technical standards in this part.* In view of this strong FCC recommendation, and because telecommunications service providers may be required to mitigate any interference caused by the equipment, in spite of any exemption, Telcordia considers compliance to FCC criteria important. If an exempt system has been properly tested and found to meet the FCC requirements, it should be labeled as compliant in accordance with the FCC labeling specifications.

FCC rules were modified regarding the emission limits that are permitted to be conducted onto AC power lines for Radio Frequency (RF) devices in accordance with the publication of the amendments in the Federal Register, Vol. 67, No. 132, July 10, 2002 (ET Docket 98-80; FCC 02-157). The intent of the rule changes is to harmonize FCC requirements with the international standards developed by the International Electrotechnical Commission (IEC), International Special Committee on Radio Frequency (CISPR).

#### 3.1.4 FCC Part 68 and ACTA Technical Criteria

FCC Part 68.7(b)<sup>[12]</sup> states that the *“technical criteria published by the Administrative Council for Technical Attachments are the presumptively valid technical criteria for the protection of the public switched telephone network from harms caused by the connection of the terminal equipment.”* FCC report and order (CC Docket No. 99-216, FCC 00-400 adopted November 9, 2000, and released December 21, 2000) privatized the process by which technical criteria for the prevention of harm are established for customer premises or terminal equipment that may be connected to the telephone network. The Order directed the industry to establish the Administrative Council on Technical Attachments (ACTA) as the balanced and open body that would assume Commission's Part 68 role for those items privatized by the Order. ANSI/TIA-968-A<sup>[13]</sup> has been established to fulfill the FCC's requirements to produce technical criteria for terminal equipment to protect the telephone network from the harms defined in Part 68.3. Telcordia requires compliance of the equipment to the conducted emissions on voiceband leads as established in ANSI/TIA-968-A.<sup>[13]</sup>

### 3.1.5 Documentation

**R3-1 [159]** The installation or instruction manual **shall** specify any special accessories such as shielded cables or special connectors that are used to achieve compliance for emission and immunity criteria.

**NOTE:** See FCC Part 15.27,<sup>[11]</sup> *Special Accessories*, for more details.

## 3.2 Emission Criteria

This section contains the electromagnetic emission requirements and objectives for an EUT.

The radiated electric field and conducted ac power ports emission criteria of this GR are predominantly the radio noise emission limits specified by the FCC Part 15 for such a device. The frequency range for radiated electric field emissions is extended beyond the FCC range to address telecommunications needs. Compliance with these criteria shall be verified in accordance with the test procedures given in [Section 3.4](#). Reports of FCC Part 15 emission tests will be accepted for the subset frequency ranges of GR-1089-CORE criteria if the tests are performed according to [Section 3.4](#). Radiated emission requirements are given for *magnetic fields*.

Conducted emissions criteria are given for telecommunications ports, all shielded and unshielded leads that interface with the EUT, in three different sets of criteria as follows:

- Analog voiceband leads as specified by ANSI/TIA-968-A.<sup>[13]</sup> These analog voiceband leads apply to equipment ports that provide only voiceband services and are directly connected to the outside telecommunications cable plant in accordance with [Appendix B](#) (e.g., Type 1 port). Reports of ANSI/TIA-968-A for conducted emission tests on voiceband leads will be accepted for the subset frequency ranges of GR-1089-CORE criteria if the tests are performed according to [Section 3.3.3.2](#).
- Telecommunications leads are equipment ports that
  - Provide Digital Subscriber Line (DSL) technologies or other high-speed digital services, and are directly connected to the outside telecommunications cable plant in accordance with [Appendix B](#) (e.g., Type 1 port)
  - Provide power of not greater than 100 VA to remote telecommunications equipment over Outside Plant (OSP) telecommunications circuits in accordance with [Section 7.6](#) (e.g., Type 1 and 3 ports).
- Signal leads are equipment ports that
  - Are not directly connected to outside telecommunications cable plant in accordance with [Appendix B](#) (e.g., Type 2 port)
  - Are directly connected to the outside telecommunications cable plant in accordance with [Appendix B](#) (e.g., Type 1 port), and are not voiceband or telecommunications leads.

Examples of signal leads are leads that connect to equipment not furnished with the EUT (such as personal computers or alarm-system panels). Other examples of signal leads are legacy systems such as a DS1 system and analog carrier technologies.

Conducted emission criteria are also given for ac and dc power ports. The new FCC requirements on conducted emission limits for ac power lines are also included in this section.

Determination of compliance with the conducted emissions criteria should be in accordance with the test procedures given in [Section 3.4](#).

### 3.2.1 Radiated Emission Criteria

#### 3.2.1.1 Electric Fields Radiated Emission Criteria for Unintentional Radiators

Tests should first be performed with any doors and covers opened per Objective **O3-3 [9]**. Doors and covers of the EUT that are not intended to be opened during EUT operation, maintenance, and/or repair need not be opened. If the criteria of Objective **O3-3 [9]** are met, then Requirements **R3-2 [8]** and **R3-4 [10]** are considered met. However, if the criteria of Objective **O3-3 [9]** are not met, as a minimum it will be necessary to retest Requirement **R3-2 [8]** at the frequencies that exceeded the limits with the doors and covers closed. The data collected in **O3-3 [8]** need only be compared to **R3-4 [10]** with the doors and covers opened to determine compliance to **R3-4 [10]**.

The lowest frequency of measurement shall be at least 10% lower than the lowest frequency generated or used by the EUT, but not less than 10 kHz. The lowest frequency of the EUT includes frequencies generated or used in any component/system of the EUT (e.g., switching power supplies, clocks, oscillators, frequency multipliers or dividers).

---

**R3-2 [8]** Radiated emissions from the EUT **shall** not exceed the levels of field strength given in [Table 3-1](#). An average detector **shall** be used for frequencies below 150 kHz and for frequencies above 1 GHz. A quasi-peak detector **shall** be used for frequencies in the range of 150 kHz to 1 GHz. This test **shall** be done with all EUT doors and covers closed. For equipment that does not have doors or covers **R3-2 [8]** **shall** be applied.

---

**Table 3-1.** Radiated Emission Requirement and Objective for Electric Fields (Sheet 1 of 2)

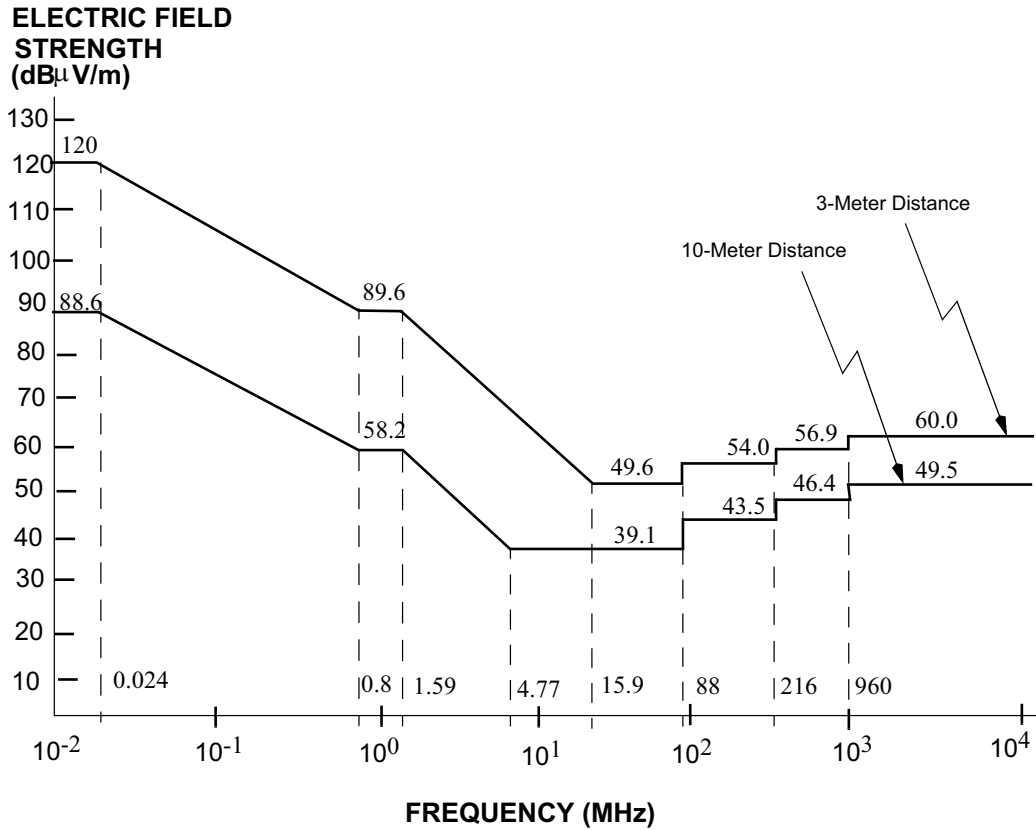
Frequency (MHz)	Field Strength (dB $\mu$ V/m)	
	Class A	Class B
0.01 — 0.024	148.6 – 60 log <sub>10</sub> d	148.6 – 60 log <sub>10</sub> d
0.024 — 0.8	116.2 – 60 log <sub>10</sub> d – 20 log <sub>10</sub> f	116.2 – 60 log <sub>10</sub> d – 20 log <sub>10</sub> f
0.8 — 1.59	118.2 – 60 log <sub>10</sub> d	118.2 – 60 log <sub>10</sub> d
1.59 — (x*/d)	126.2 – 60 log <sub>10</sub> d – 40 log <sub>10</sub> f	126.2 – 60 log <sub>10</sub> d – 40 log <sub>10</sub> f

**Table 3-1.** Radiated Emission Requirement and Objective for Electric Fields (Sheet 2 of 2)

Frequency (MHz)	Field Strength (dB $\mu$ V/m)	
	Class A	Class B
(x*/d) — 88	59.1 – 20 log <sub>10</sub> d	49.5 – 20 log <sub>10</sub> d
88 — 216	63.5 – 20 log <sub>10</sub> d	53.0 – 20 log <sub>10</sub> d
216 — 960	66.4 – 20 log <sub>10</sub> d	55.5 – 20 log <sub>10</sub> d
960 — 10000	69.5 – 20 log <sub>10</sub> d	63.5 – 20 log <sub>10</sub> d
* x is equal to 47.7 for Class A and 60.5 for Class B.		

In **Table 3-1**, **f** is the frequency of the emission under investigation in MHz. The measurement distance, **d** (in meters), is the horizontal distance between the center of the measuring antenna (or where it is closest to the EUT) and the closest point of any part of the system as prescribed in ANSI C63.4-2003.<sup>[14]</sup> This distance should be between 3 meters and 30 meters for frequencies below 1 GHz. At 1 GHz and above, the distance should be at least 1 meter. The stricter field strength limit applies at the edge between two frequency bands. As an illustration of the relationship among the levels for the various frequency bands, the limits for Class-A digital devices are plotted in **Figure 3-1** for 3-meter and 10-meter measurement distances.

**Figure 3-1 R3-2 [8] Requirement and O3-3 [9] Objective Limits for Class-A Electric Field Emissions at 3-Meter and 10-Meter Distances**



**O3-3 [9]** Radiated emissions from the EUT should not exceed the levels of field strength given in **Table 3-1** with all doors and covers open. Doors and covers that are not intended to be opened during operation, maintenance, and/or repair need not be opened.

**R3-4 [10]** Radiated emissions from Class A and B EUTs **shall not** exceed the levels of field strength given in **Table 3-2**. An average detector **shall** be used for frequencies below 150 kHz and for frequencies above 1 GHz. A quasi-peak detector **shall** be used for frequencies in the range of 150 kHz to 1 GHz. This test **shall** be done with all the EUT doors and covers open. Doors and covers that are not intended to be opened during EUT operation, maintenance, and/or repair need not be opened.

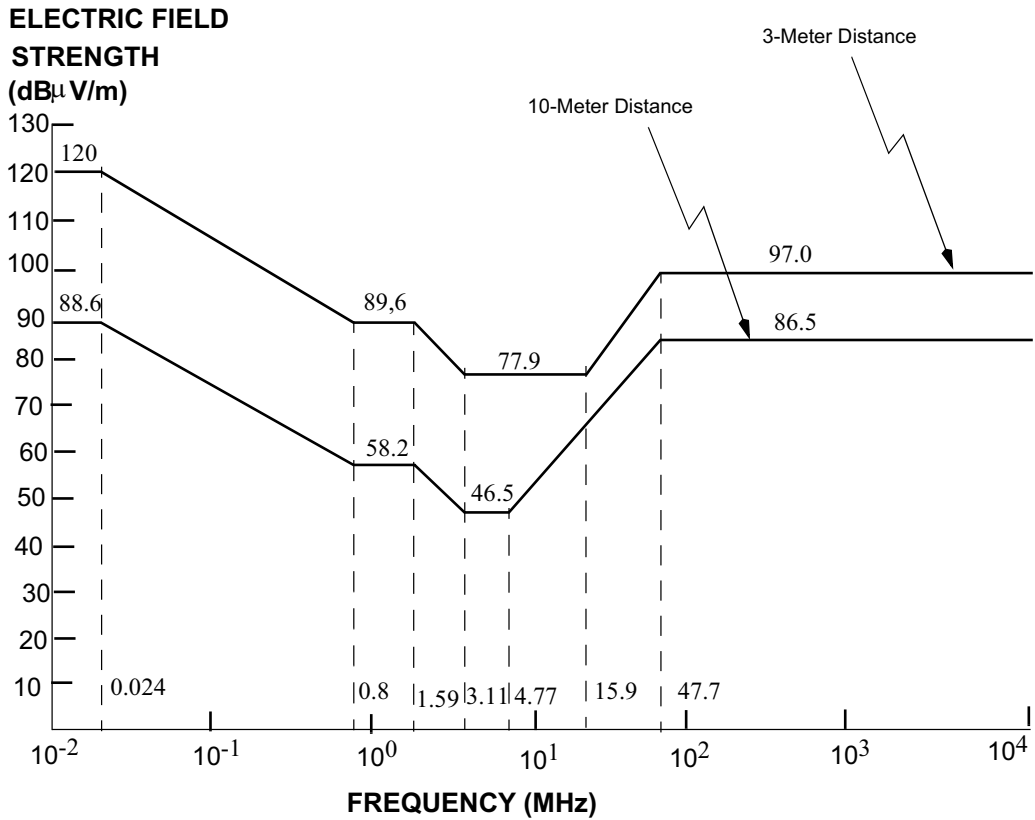
**Table 3-2** Radiated Emission Requirement for Electric Fields (Doors and Covers Open)

Frequency (MHz)	Field Strength (dB $\mu$ V/m)
0.01 to 0.024	148.6 – 60 log <sub>10</sub> d
0.024 to 0.8	116.2 – 60 log <sub>10</sub> d – 20 log <sub>10</sub> f
0.8 to 1.59	118.2 – 60 log <sub>10</sub> d
1.59 to 3.11	126.2 – 60 log <sub>10</sub> d – 40 log <sub>10</sub> f
3.11 to 47.7/d	106.5 – 60 log <sub>10</sub> d
47.7/d to 47.7	39.4 – 20 log <sub>10</sub> d + 40 log <sub>10</sub> f
47.7 to 10000	106.5 – 20 log <sub>10</sub> d

In **Table 3-2**, **f** is the frequency of the emission under investigation in MHz. The measurement distance, **d** (in meters) is the horizontal distance between the center of the measuring antenna (or where it is closest to the EUT) and the closest point of any part of the system as prescribed in ANSI C63.4-2003<sup>[14]</sup>. This distance should be between 3 meters and 30 meters for frequencies below 1 GHz. At 1 GHz and above, the distance should be at least 1 meter. The stricter field strength limit applies at the edge between two frequency bands. As an illustration of the relationship among the levels for the various frequency bands, the limits for Class-A digital devices are plotted in **Figure 3-2** for 3-meter and 10-meter measurement distances.



**Figure 3-2 R3-4 [9] Requirement Limits for Electric Field Emissions at 3-Meter and 10-Meter Distances**



3.2.1.2 Electric Fields Radiated Emission Criteria for Intentional Radiators

See Appendix D for definitions on unwanted emissions and necessary bandwidth.

- R3-5 [160]** The EUT shall be certified to applicable FCC parts in 47 CFR.
- R3-6 [161]** Radiated emissions from the EUT shall not exceed the levels of field strength provided in Table 3-1. The limits apply to the frequencies of unwanted emissions and not the fundamental frequency. An average detector shall be used for frequencies below 150 kHz and for frequencies above 1 GHz. A quasi-peak detector shall be used for frequencies in the range of 150 kHz to 1 GHz. This test shall be done with all EUT doors and covers closed.
- R3-7 [162]** When testing the electric-field radiated emissions of the EUT, the emissions at the fundamental frequency of the EUT shall be measured and provided in a test report.

- O3-8 [163]** Radiated emissions from the EUT should not exceed the levels of field strength given in [Table 3-1](#) for Class A with all doors and covers open. The limits apply to the frequencies of unwanted emissions and not the fundamental frequency. Doors and covers that are not intended to be opened during operation, maintenance, and/or repair need not be opened.

### 3.2.1.3 Magnetic Fields Radiated Emission Requirement

- R3-9 [11]** Radiated emissions from the EUT **shall** not exceed the levels of field strength obtained from the following equation in the frequency range of 60 Hz through 30 MHz.

$$H = E - 51.5$$

In this equation, **E** is the electric-field intensity in dB $\mu$ V/m as obtained from [Table 3-1](#); **H** is the magnetic-field intensity limit in dB $\mu$ A/m; and the constant, 51.5, is the decibel equivalent of the free-space wave impedance of a plane wave. Extrapolation of magnetic-field intensity limits is based on the electric-field intensity obtained from using the equations of [Table 3-1](#) for the particular distance greater than 3 meters. At these low frequencies, the actual free-space wave impedance may not be 377 ohms. For all frequencies below 10 kHz, the value for **E** should be taken as that value obtained from [Table 3-1](#) at 10 kHz.

This test shall be done with all the EUT doors and covers open, and repeated with the doors and covers closed. Doors and covers not intended to be opened during operation, maintenance, and/or repair need not be opened. The tests should first be performed with the doors and covers open. If the criteria are met with the doors and covers open, then the criteria with the doors and covers closed are also considered to have been met. However, if the criteria with the doors and covers open are not met, as a minimum, it will be necessary to retest at the frequencies that exceeded the limits with the doors and covers closed. An average detector shall be used for frequencies below 150 kHz. A quasi-peak detector shall be used for frequencies above 150 kHz. The measurement shall be made with the antenna in the coaxial (loop parallel) and planar (loop perpendicular) orientations.

The lowest frequency of measurement shall be at least 10% lower than the lowest frequency generated or used by the EUT, but shall not be less than 60 Hz. The lowest frequency of the EUT includes frequencies generated or used in any component/system of the EUT (e.g., switching power supplies, clocks, oscillators, frequency multipliers or dividers). If the EUT is ac powered, the fundamental ac power frequency is excluded from the determination of the lowest measurement frequency.

### 3.2.2 Conducted Emission Criteria for Power Ports

This section applies to network equipment powered by ac and dc power systems in the telecommunications environment. This section does not address the interfaces of network equipment that provide power over telecommunications circuits (see [Section 7.6](#)). These interfaces shall meet the criteria discussed in [Section 3.2.3.3](#).

### 3.2.2.1 Conducted Emission Requirements for AC Power Ports

**R3-10 [12]** Conducted emissions from the EUT into low-voltage ac public utility power lines **shall not** exceed the average voltage limits and quasi-peak voltage limits given in [Table 3-3](#) for Class A EUT or [Table 3-4](#) for Class B EUT when using an average and a quasi-peak detector, respectively, and measured in accordance with [Section 3.4.5.1.1](#).

In [Table 3-3](#) and [Table 3-4](#), the frequency is that of the emission under investigation, and the stricter limit applies at the edge between the two frequency bands.

**Table 3-3** Conducted Emission Limits for AC Power Ports for Class A Equipment

Frequency (MHz)	Maximum Radio-Frequency Line Voltage Limits (dB $\mu$ V)	
	Quasi-Peak	Average
0.15 to 0.5	79	66
0.5 to 30	73	60

**Table 3-4** Conducted Emission Limits for AC Power Ports for Class B Equipment

Frequency (MHz)	Maximum Radio-Frequency Line Voltage Limits (dB $\mu$ V)	
	Quasi-Peak	Average
0.15 to 0.5	66 to 56* (-19.1 log <sub>10</sub> f + 50.25)	56 to 46* (-19.1 log <sub>10</sub> f + 40.25)
0.5 to 5	56	46
5 to 30	60	50

\* Decreases linearly with the logarithm of the frequency (f). The frequency under investigation is in MHz.

### 3.2.2.2 Conducted Emission Requirements for AC and DC Power - Current

**R3-11 [13]** Conducted common-mode emissions from the EUT into low-voltage ac public utility power lines and dc power conductors **shall not** exceed the levels given in [Table 3-5](#) measured in accordance with [Section 3.4.5.1.2](#) and [Section 3.4.5.1.3](#). An average detector **shall** be used for frequencies below 150 kHz. A quasi-peak detector **shall** be used for frequencies above 150 kHz.

**Table 3-5** Conducted Emission Requirements for AC and DC Power Ports — Current

Frequency (MHz)	Maximum Line Current (dB $\mu$ A)
0.01 to 0.27	79
0.27 to 0.8	$67.6 - 20 \log_{10} f$
0.8 to 30	69.5

In **Table 3-5**, **f** is the frequency of the emission under investigation in MHz. These limits are plotted in **Figure 3-3**.

The lowest frequency of measurement shall be at least 10% lower than the lowest frequency generated or used by the EUT, but not less than 10 kHz. The lowest frequency of the EUT includes frequencies generated or used in any component/system of the EUT (e.g., switching power supplies, clocks, oscillators, frequency multipliers or dividers).

### 3.2.3 Conducted Emission Criteria for Telecommunications Ports

#### 3.2.3.1 Conducted Emission Requirements for Signal Leads — Current

This section applies to signal leads defined in **Section 3.2** and **Appendix D**.

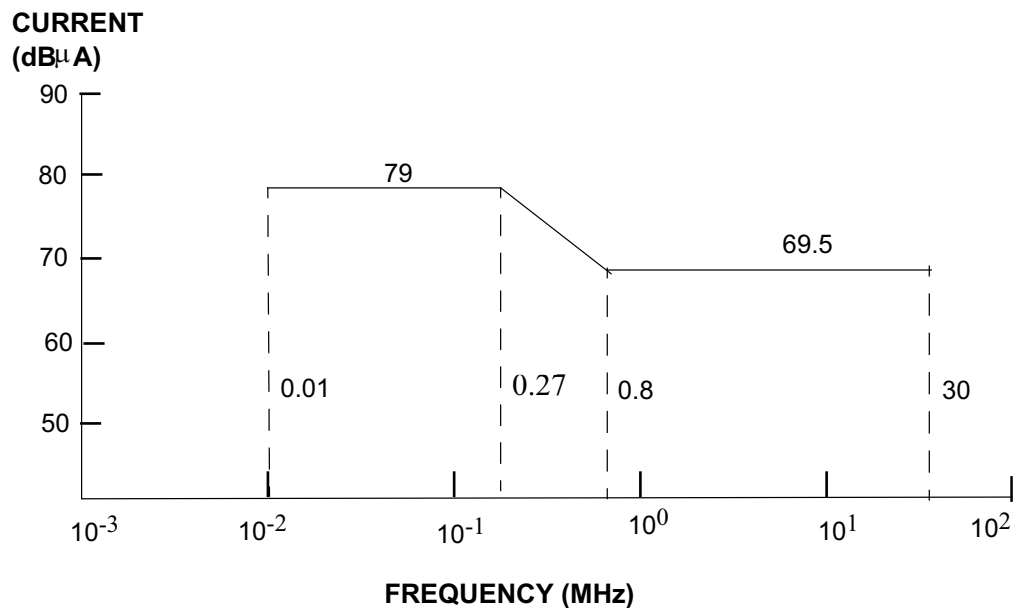
**R3-12 [128]** Conducted common-mode emissions from the EUT into signal leads **shall not** exceed the levels given in **Table 3-6** measured in accordance with **Section 3.4.5.1.4**. An average detector **shall** be used for frequencies below 150 kHz. A quasi-peak detector **shall** be used for frequencies above 150 kHz.

**Table 3-6** Conducted Emission Requirements for Signal Ports — Current

Frequency (MHz)	Maximum Line Current (dB $\mu$ A)
0.01 to 0.15	79
0.27 to 0.8	$67.6 - 20 \log_{10} f$
0.8 to 30	69.5

In **Table 3-6**, **f** is the frequency of the emission under investigation in MHz. These limits are plotted in **Figure 3-3**.

The lowest frequency of measurement shall be at least 10% lower than the lowest frequency generated or used by the EUT, but not less than 10 kHz. The lowest frequency of the EUT includes frequencies generated or used in any component/system of the EUT (e.g., switching power supplies, clocks, oscillators, frequency multipliers or dividers).

**Figure 3-3** Conducted Emissions Limits on Signal Leads

### 3.2.3.2 Conducted Emission Requirements for Analog Voiceband Leads

This section applies to voiceband leads defined in [Section 3.2](#) and [Appendix D](#).

**R3-13 [14]** Unintentional conducted emissions from analog voiceband leads **shall not** exceed the levels given in [Table 3-7](#) for metallic voltage (also known as “differential-mode voltage”) and [Table 3-8](#) for longitudinal voltage (also known as “common-mode voltage”) measured in accordance with [Section 3.4.5.1.6](#). These limits are established to protect the Public Switched Telephone Network.

In [Table 3-7](#) and [Table 3-8](#),  $f$  is the center frequency in kHz, of each of the possible 8-kHz bands beginning at 8 kHz. The maximum voltage is the Root-Mean-Square (RMS [lowercase “rms” is used in equations]) voltage, averaged over 100 milliseconds, measured in all of the possible 8-kHz bands within the indicated frequency range. The RMS value of the voltage components in the frequency range 270 kHz to 6 MHz should be averaged over 2  $\mu$ s.

As illustrations of the relationships among the levels for the various frequency bands, the metallic voltage limits are plotted in [Figure 3-4](#) and the longitudinal voltage limits in [Figure 3-5](#).

**Table 3-7** Metallic Voltage Limit on Analog Voiceband Leads

Center Frequency (f) of 8-kHz Bands (kHz)	Maximum Voltage in All 8-kHz Bands (dBV)	Terminating Impedance	
		Metallic (Ohms)	Longitudinal (Ohms)
8 to 12	$-(6.4 + 12.6 \log_{10} f)$	300	500
12 to 90	$23 - 40 \log_{10} f$	135	90
90 to 270	- 55	135	90
270 to 6000	- 15	135	90

**Table 3-8** Longitudinal Voltage Limit on Analog Voiceband Leads

Center Frequency (f) of 8-kHz Bands (kHz)	Maximum Voltage in All 8-kHz Bands (dBV)	Terminating Impedance	
		Metallic (Ohms)	Longitudinal (Ohms)
8 to 12	$-(18.4 + 20 \log_{10} f)$	300	500
12 to 42	$3 - 40 \log_{10} f$	135	90
42 to 270	- 62	135	90
270 to 6000	- 30	135	90

### 3.2.3.3 Conducted Emission Objectives for Telecommunications Leads

This section applies to telecommunications leads defined in [Section 3.2](#) and [Appendix D](#).

- O3-14 [129]** This objective will become a requirement effective January 1, 2008. Conducted emissions from telecommunications leads **should not** exceed the longitudinal (also known as “common-mode”) rms current limits and peak current limits given in [Table 3-9](#) and [Table 3-10](#) using an rms and a peak detector, respectively, and measured in accordance with [Section 3.4.5.1.6](#). The lower limit applies at the band edges.

In [Table 3-9](#) and [Table 3-10](#), **f** indicates the center frequency in MHz, of each possible measuring bandwidth. The limits can be measured by using different bandwidths less than 10 kHz as described in [Section 3.4.3.5](#) (e.g., 1-kHz, 3-kHz, and 4-kHz bandwidths). In [Table 3-9](#), the maximum current is the rms current, averaged over 2 seconds, measured in all frequencies in the indicated frequency range.

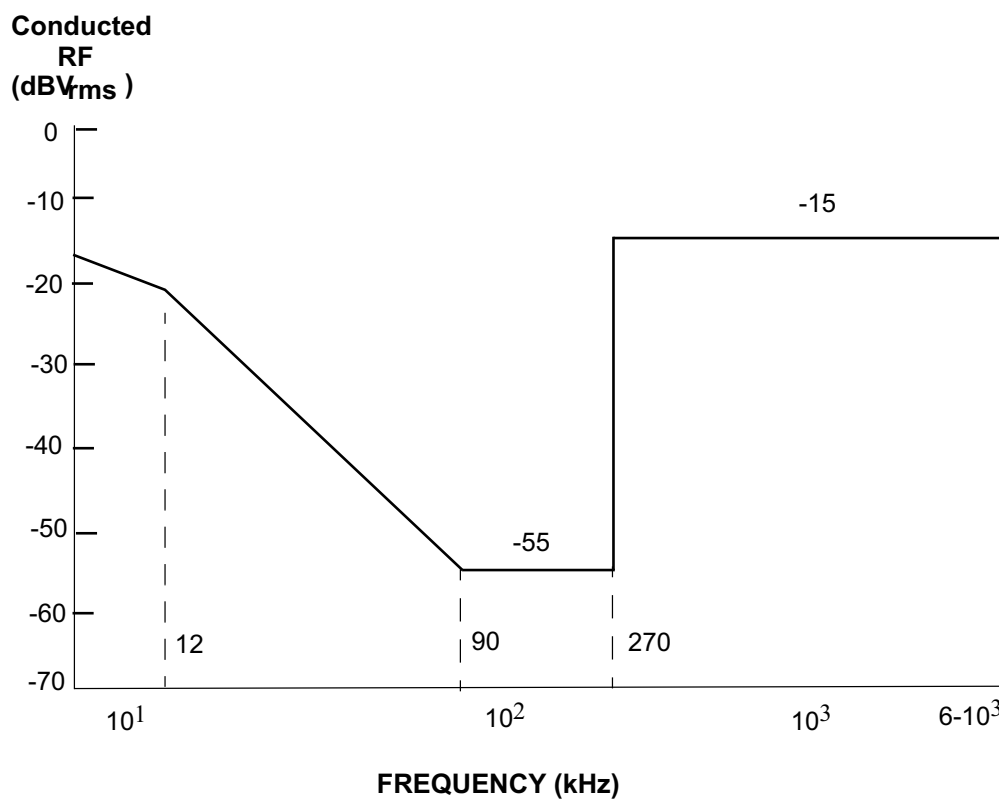
**Table 3-9** Longitudinal RMS Current Limits on Telecommunications Leads

Frequency Range (MHz)	Maximum rms Current in Each Measuring Bandwidth (B) (dB $\mu$ A)
0.004 to 0.15	$30.5+20\log_{10}[\mathbf{B}(\text{kHz})/10]^{0.5*}$
0.15 to 0.5	$30.5+20\log_{10}[\mathbf{B}(\text{kHz})/10]^{0.5}$ to $20.5+20\log_{10}[\mathbf{B}(\text{kHz})/10]^{0.5**}$ ( $-19.1 \log_{10} \mathbf{f} + 14.7+20\log_{10}[\mathbf{B}(\text{kHz})/10]^{0.5}$ )
0.5 to 30	$20.5+20\log_{10}[\mathbf{B}(\text{kHz})/10]^{0.5}$
* <b>B</b> indicates the bandwidth used for the measurement in kHz.	
** Decreases linearly with the logarithm of the frequency ( <b>f</b> ) in MHz.	

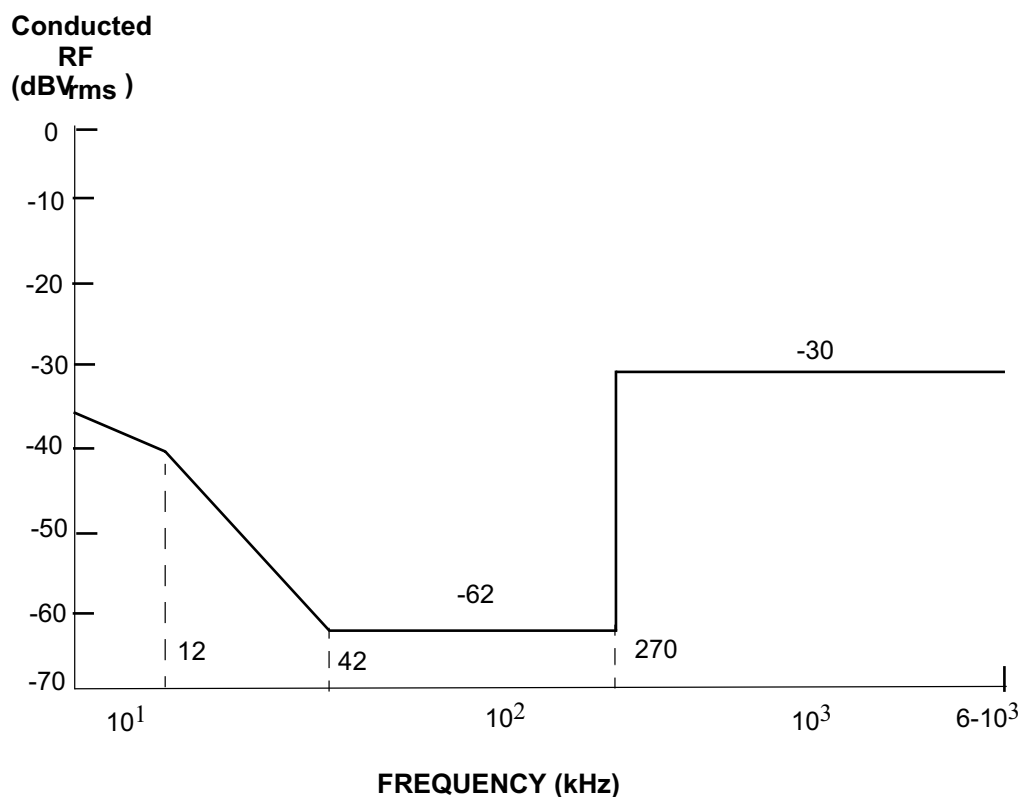
**Table 3-10** Longitudinal Peak Current Limits on Telecommunications Leads

Frequency Range (MHz)	Maximum Peak Current in Each Measuring Bandwidth (B) (dB $\mu$ A)
0.004 to 0.15	$40.5+20\log_{10}[\mathbf{B}(\text{kHz})/10]^{0.5*}$
0.15 to 0.5	$40.5+20\log_{10}[\mathbf{B}(\text{kHz})/10]^{0.5}$ to $30.5+20\log_{10}[\mathbf{B}(\text{kHz})/10]^{0.5**}$ ( $-19.1 \log_{10} \mathbf{f} + 24.7+20\log_{10}[\mathbf{B}(\text{kHz})/10]^{0.5}$ )
0.5 to 30	$30.5+20\log_{10}[\mathbf{B}(\text{kHz})/10]^{0.5}$
* <b>B</b> indicates the bandwidth used for the measurement in kHz.	
** Decreases linearly with the logarithm of the frequency ( <b>f</b> ) in MHz.	

Figure 3-4 Analog Voiceband Leads Conducted Emission Limits (Metallic)





**Figure 3-5** Analog Voiceband Leads Conducted Emission Limits (Longitudinal)

### 3.3 Immunity Criteria

Radiated immunity requirements and conditional requirements are given for electric fields.

Conducted immunity criteria are given for telecommunications ports, all shielded and unshielded leads that interface with the EUT, in three different sets of criteria for:

- Voiceband leads as defined in [Section 3.2](#) and [Appendix D](#)
- Telecommunications leads as defined in [Section 3.2](#) and [Appendix D](#)
- Signal leads as defined in [Section 3.2](#) and [Appendix D](#).

Conducted immunity criteria are also given for ac and dc power ports.

Determination of compliance with these requirements, conditional requirements, and objectives should be in accordance with the test procedures given in [Section 3.5](#).

### 3.3.1 Radiated Immunity Criteria

It is suggested that tests first be performed with doors and covers open. If the criteria are met with the doors and covers open, then the criteria with the doors and covers closed are considered to have been met. However, if the criteria with the doors and covers open are not met, it will be necessary to retest at least the failed frequencies with the doors and covers closed.

#### 3.3.1.1 Electric Fields Radiated Immunity Criteria with Doors and Covers Closed

**R3-15 [15]** This requirement has been deleted.

**R3-16 [16]** The EUT **shall** perform properly when subjected to the calibration electric fields of 138.6 dB $\mu$ V/m (8.5 V/m), RMS value of the unmodulated test signal over the frequency range of 0.01 through 10,000 MHz. During the test, the test signal **shall** be modulated in accordance with [Section 3.5.5.3.6](#). In general, performance criteria are given in the applicable Telcordia Generic Requirements, national and international standards; examples of particular performance criteria are found in [Section 3.5.3](#). This test is to be performed with all the EUT doors and covers closed.

#### 3.3.1.2 Electric Fields Radiated Immunity Criteria with Doors and Covers Open

**R3-17 [17]** This requirement has been deleted.

**R3-18 [18]** The EUT **shall** perform properly when it is subjected to calibration electric field of 138.6 dB $\mu$ V/m (8.5 V/m), RMS value of the unmodulated test signal over the frequency range of 0.01 through 10,000 MHz. During the test, the test signal **shall** be modulated in accordance with [Section 3.5.5.3.6](#). In general, performance criteria are found in the applicable Telcordia Generic Requirements, national and international standards; examples of particular performance criteria are found in [Section 3.5.3](#). This test **shall** be done with all the EUT doors and covers open, except for doors and covers that are not intended to be opened during EUT operation, maintenance, and/or repair, which may remain closed.

### 3.3.2 Conducted Immunity Criteria for AC and DC Power Ports

This section applies to network equipment powered by ac and dc power systems in the telecommunications environment. This section does not address the interfaces of network equipment that provide power over telecommunications circuits (see [Section 7.6](#)). The conducted immunity criteria for these interfaces are discussed in [Section 3.3.3](#).

**R3-19 [19]** This requirement has been deleted.

**R3-20 [130]** The EUT **shall** perform properly when electromagnetic energy is injected longitudinally (common-mode) into each power port of the EUT, one port at a time, at the previously calibrated limits given in [Table 3-11](#). If the EUT fails the pre-calibrated limit of [Table 3-11](#) because of excessive coupling, the injected current into the EUT leads may be adjusted to a level 6 dB above the calibration current of [Table 3-11](#). If the EUT performs properly after the current is adjusted, then the EUT is considered to have met the criteria. In general, performance criteria are found in the applicable Telcordia Generic Requirements, national and international standards; examples of particular performance criteria are found in [Section 3.5.3](#). The lower limit applies at the band edges. In [Table 3-11](#), **f** is the frequency of the injected electromagnetic energy in MHz.

**Table 3-11** Conducted Immunity Requirements for Power Ports

Frequency (MHz)	Minimum Calibration Line Current (dB $\mu$ A <sub>rms</sub> )
0.01 to 0.15	89 to 80.5* (-7.25 log <sub>10</sub> f + 74.5)
0.15 to 30	80.5

\* Decreases linearly with the logarithm of the frequency (**f**).

### 3.3.3 Conducted Immunity Criteria for Telecommunications Ports

#### 3.3.3.1 Conducted Immunity Requirements for Signal Leads

This section applies to signal leads defined in [Section 3.2](#) and [Appendix D](#).

**R3-21 [131]** The EUT **shall** perform properly when electromagnetic energy is injected longitudinally (common-mode) into signal leads associated with each kind of port of the EUT, one kind of port at a time, at the previously calibrated limits given in [Table 3-11](#). At least one of the identical ports in the EUT **shall** be tested. If the EUT fails the pre-calibrated limit of [Table 3-11](#) because of excessive coupling, the injected current into the EUT leads may be adjusted to a level 6 dB above the calibration current of [Table 3-11](#). If the EUT performs properly after the current is adjusted, then the EUT is considered to have met the criteria. In general, performance criteria are found in the applicable Telcordia Generic Requirements, national and international standards; examples of particular performance criteria are found in [Section 3.5.3](#). In [Table 3-11](#), **f** is the frequency of the injected electromagnetic energy in MHz.

#### 3.3.3.2 Conducted Immunity Objectives for Voiceband and Telecommunications Leads

This section applies to voiceband and telecommunications leads defined in [Section 3.2](#) and [Appendix D](#).

**O3-22 [164]** This objective will become a requirement effective January 1, 2008. The EUT **should** perform properly when electromagnetic energy is injected longitudinally

(common-mode) into each port of associated voiceband and telecommunications leads of the EUT, one port at a time, at the previously calibrated limits given in Table 3-12. If the EUT fails the pre-calibrated limit of Table 3-12 because of excessive coupling, the injected current into the EUT leads may be adjusted to a level 6 dB above the calibration current of Table 3-12. If the EUT performs properly after the current is adjusted, then the EUT is considered to have met the criteria. In general, performance criteria are found in the applicable Telcordia Generic Requirements, national and international standards; examples of particular performance criteria are found in Section 3.5.3. In Table 3-12,  $f$  is the frequency of the injected electromagnetic energy in MHz.

**Table 3-12** Conducted Immunity Objectives for Voiceband and Telecommunications Leads

Frequency (MHz)	Minimum Calibration Line Current (dB $\mu$ A <sub>rms</sub> )
0.01 to 30	89

### 3.4 Measurement Procedures Associated with Emissions

#### 3.4.1 Scope

This section gives procedures to be used in measuring conducted and radiated emissions from an EUT for verifying compliance with the emission limits given in Section 3.2. The methods are intended to provide a common basis for analyzing an EUT relative to the emission limits.

#### 3.4.2 Related Standards

Section 3.4 follows procedures of the American National Standard Institute (ANSI) C63.4-2003, *Methods for Measurement of Radio Noise Emission from Low Voltage Electrical and Electronic Equipment in the Range of 9 kHz to 40 GHz*.<sup>[14]</sup>

#### 3.4.3 Measuring Instrumentation

##### 3.4.3.1 General

Radiated and conducted emission measurements should be made with a radio noise meter conforming to ANSI C63.2-1996,<sup>[15]</sup> CISPR 16-1-1,<sup>[16]</sup> or MIL-STD-461E.<sup>[17]</sup> A spectrum analyzer may be used as the measuring instrument, provided that it is used, when necessary, with appropriate accessories to provide sufficient sensitivity and overload protection to ensure accurate, repeatable measurements of all emissions over the specified frequency range. Related equipment needed would

depend on the measurement situation and could include preamplifiers for sensitivity improvement, filters and/or attenuators for overload protection, and additional quasi-peak detection circuitry. Overload is defined as harmonic distortion, intermodulation, or gain compression of spectrum analyzer input signals.

Precautions may have to be taken to ensure that the spectrum analyzer operates linearly before taking final measurements. A verification of linear operation of the test equipment used (EMI receivers and spectrum analyzers) may have to be performed before making final measurements. Other instruments, besides a radio noise meter or spectrum analyzer, may be used for certain restricted and specialized measurements when correlation data has been taken to establish methods of converting data to that achieved with instrumentation described in ANSI C63.2-1996,<sup>[15]</sup> CISPR 16-1-1,<sup>[16]</sup> or MIL-STD-461E.<sup>[17]</sup>

Any current probe capable of measuring to the limits in this section, conforming to CISPR 16-1-2,<sup>[18]</sup> may be used. The probe used should have adequate insulation to prevent direct conduction from the leads under test.

### 3.4.3.2 Analog Voiceband Leads Emissions Measurement Instrumentation

#### 3.4.3.2.1 Frequency-Selective Meter

A frequency-selective meter is used for the measurement frequency range from 4 kHz to 270 kHz for the narrowband measurement procedure and 4 kHz to 6 MHz for the broadband measurement procedure. The frequency-selective meter may consist of a receiver, spectrum analyzer, and frequency-selective voltmeter, or a combination of separate bandpass filter (or high- and low-pass filters in tandem) and a true RMS voltmeter. For metallic measurements, the meter must have a balanced input unless a balanced-to-unbalanced (balun) transformer is used (refer to [Section 3.4.3.2.2](#)). The frequency response of the meter should be flat to 6 MHz.

#### 3.4.3.2.2 Termination Networks

The impedance values of the termination networks are obtained from the ANSI/TIA-968-A.<sup>[13]</sup> [Figure 3-6](#) shows a schematic diagram of the termination networks. The longitudinal conversion loss of the termination network should be greater than 60 dB in the frequency range from 4 kHz to 1 MHz, and greater than 40 dB in the frequency range from 1 MHz to 6 MHz.

A balun transformer can be used to implement the termination network. [Figure 3-7](#) shows examples of the balun termination networks for frequencies above 12 kHz. This type of termination network allows the use of unbalanced frequency-selective meters.

Appropriate corrections must be made to the receiver readings based on the termination network used.

The on-hook state of customer premises equipment is simulated by inserting two matched 5- $\mu$ F ( $\pm 0.5\%$ ) capacitors in series with the input leads of the termination network. The capacitors should not become inductive below 6 MHz. Parasitic inductance may be experienced in the capacitors and they will act as inductors

above their series resonant frequency. Therefore, consideration should be given to the type of capacitor (such as ceramic or mylar) to be used. Good results have been obtained with metallized-polypropylene capacitors. When tests are being conducted in the off-hook state, a single 5- $\mu$ F capacitor placed in the common lead (reference point) of the termination network shown in Figure 3-6 may be necessary to block direct current. To simulate the off-hook state, it may be necessary to insert the two matched 5- $\mu$ f capacitors in series with the input leads of the termination network, and install a 3-k $\Omega$  resistor across tip-and-ring on the EUT side of the 5- $\mu$ f capacitor.

### 3.4.3.3 Telecommunications Leads Emissions Measurement Instrumentation

For rms common-mode current limits, a spectrum analyzer or measuring receiver utilizing an rms detector is used for the measurement frequency range. The rms receiver shall be in accordance with Clause 7 of CISPR 16-1-1<sup>[16]</sup> and shall have a 6-dB bandwidth.

For peak common-mode current limits, a spectrum analyzer or measuring receiver utilizing a peak detector is used for the measurement frequency range. The peak receiver shall be in accordance with Clause 5 of CISPR 16-1-1<sup>[16]</sup> and shall have a 6-dB bandwidth.

### 3.4.3.4 Measuring Instrument Calibration

The calibration of the measuring instrument, including any accessories that may affect such calibration, should be checked frequently enough to ensure its accuracy. Adjustments should be made and correction factors applied to measured data in accordance with the specifications of the specific instrument.

### 3.4.3.5 Detector Function Selection and Bandwidth

For measuring receivers or spectrum analyzers that include weighting circuits, the detector function should be set in accordance with the CISPR 16-1-1.<sup>[16]</sup>

The minimum bandwidths for the instrument used to measure quasi-peak and average conducted and radiated emissions should be the 3-dB bandwidths for frequencies below 10 kHz and the 6-dB bandwidths for frequencies above 10 kHz shown in Table 3-13.

**Table 3-13 Instrumentation Bandwidths**

Frequency	Bandwidth
60 Hz to 1 kHz	10 Hz
1 kHz to 10 kHz	100 Hz
10 kHz to 0.15 MHz	200 Hz
0.15 MHz to 30 MHz	9 kHz
30 MHz to 1 GHz	120 kHz
1 GHz to 10 GHz	1 MHz

The instrument used to measure rms and peak conducted emissions for telecommunications leads should have a 6-dB bandwidth. Bandwidths up to 10 kHz may be used for these measurements.

Alternatively, instruments, receivers, or spectrum analyzers, with a 3-dB bandwidth in accordance with CISPR-16-1-1<sup>[16]</sup> can be used to measure conducted and radiated emissions. However, the measurements shall be within the limits specified in Section 3.2 and without any presumed correction for the difference between 3-dB and 6-dB bandwidths.

These bandwidths have tolerances as prescribed in CISPR 16-1-1.<sup>[16]</sup>

Alternatively, measuring receivers and spectrum analyzers without CISPR weighting circuits may be used, provided measurements are made on a peak basis and recorded as observed (without any presumed correction for the difference between CISPR quasi-peak and peak detector function). Post-detector video filters, if used, should be set 3 times wider than the resolution used to ensure that no averaging is in the measurement.

Data taken with measuring instrumentation using logarithmic Interconnecting Frame (IF) amplifiers when using the average function, represents the average of the logarithm of the voltage level at the output of the detector. If the emission observed is impulsive in nature, the observed values will be materially lower than the true average of voltage. The deviation is dependent on the pulse repetition frequency of the signal to be measured. Instrument overload is likely to occur with linear IF systems if the emission pulse duty cycle is less than that for which the measuring instrumentation is rated.

When measuring impulsive signals, a data correction of the measured peak amplitude is to be performed to address the pulse desensitization. This requires the determination of the duty cycle of the emission. After the pulse desensitization correction factor has been applied, the average value of emissions can be calculated.

#### 3.4.3.6 Antennas

A calibrated, tuned, half-wavelength dipole antenna is preferred for measuring the level of radiated (electric-field) emissions (see ANSI C63.5-2004).<sup>[19]</sup> Other linearly polarized antennas (see the list below) are acceptable provided the results obtained with such antennas can be correlated to those obtained with a tuned dipole. The antenna should be capable of measuring both horizontal and vertical polarizations at frequencies above 30 MHz. For a description of the height and location of the antenna (see Section 8 of ANSI C63.4-2003).<sup>[14]</sup>

The following antenna height information applies for measurement frequencies above 30 MHz. The height of the center of the antenna should be capable of being varied from 1 to 4 meters. Notwithstanding the height range just given, the minimum antenna height for each frequency and polarization should be limited so that no element of the receiving antenna is less than 25 centimeters from any reflecting surface. For electric field measurements below 30 MHz, the antenna is not varied in height but is placed on the ground plane, and the measurements are made only for vertical polarization. For magnetic field measurements, the antenna shall be

positioned in the coaxial (loop parallel) and planar (loop perpendicular) orientations at the specified distance from the EUT. The center of the loop shall be 1 meter above the ground plane.

The following antennas should be used for radiated emission measurements:

1. 60 Hz to 30 MHz

For magnetic-field emission measurements, a loop antenna should be used.

2. 10 kHz to 30 MHz

For electric-field emission measurements, a 41-inch rod antenna with an appropriate matching network should be used. Other linearly polarized, calibrated antennas may also be used, including active antennas. If the antenna has a counterpoise, it should be bonded to the open-area test site ground plane.

3. 30 MHz to 200 MHz

Initial emission measurements should be performed using a biconical antenna. Other linearly polarized, calibrated antennas may also be used. Where it is practical to do so, final measurements of several of the most significant emissions should be performed using a calibrated, tuned, half-wave dipole antenna.

4. 200 MHz to 1 GHz

Initial emission measurements should be performed using a log-periodic antenna. Other linearly polarized, calibrated antennas may also be used. Where it is practical to do so, final measurement of several of the most significant emissions should be performed using a calibrated, tuned, half-wave dipole antenna.

5. 1 GHz to 10 GHz

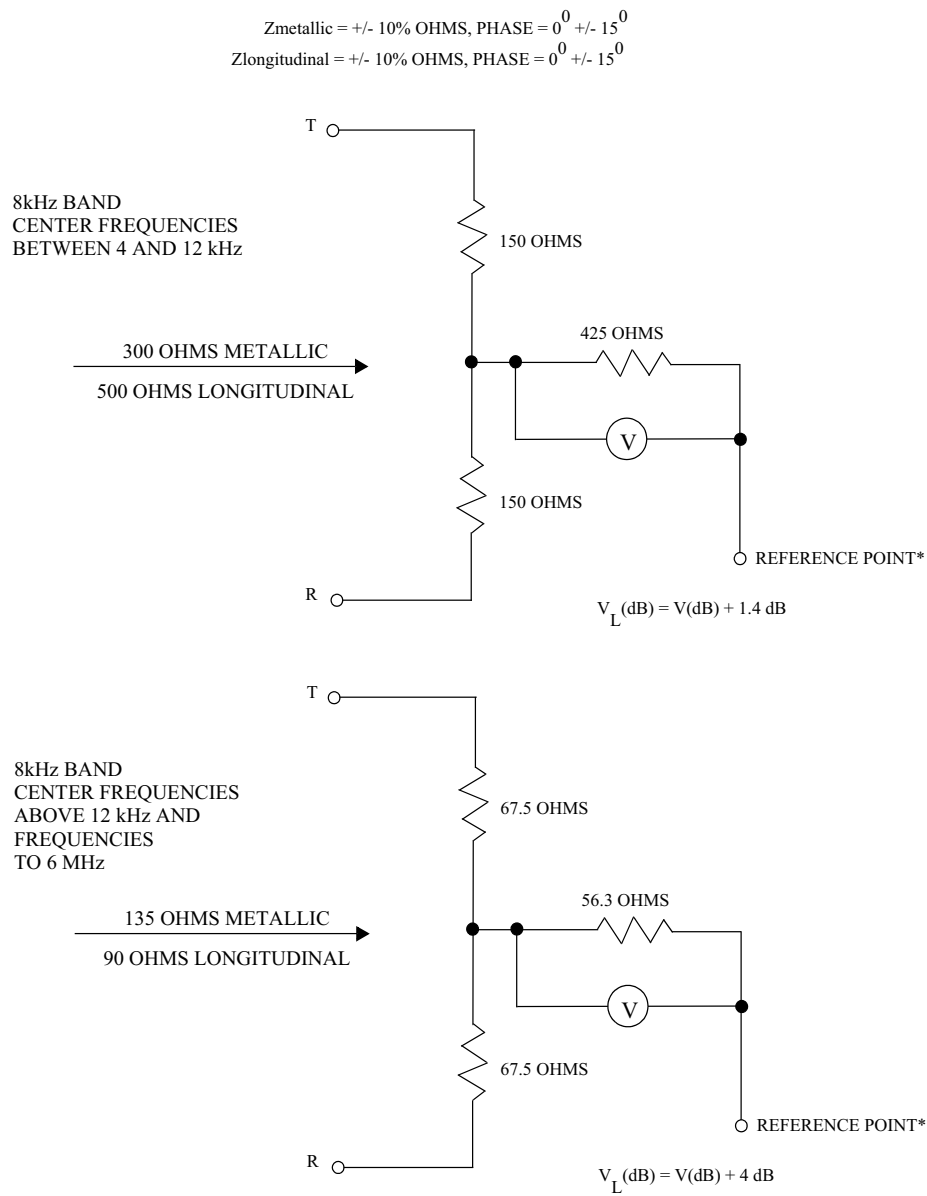
Emission measurements should be performed using a log-periodic or horn (such as a ridged-guide) antenna. Other linearly polarized antennas may also be used.

If active antennas or preamplifiers are used, the following precautions should be followed:

- Ensure the antenna preamplifier does not overload in high signal conditions. This can occur in high ambient environments or when measuring at a close distance to a source. This should be monitored closely during testing to ensure that EUT operating modes or positions relative to the antenna do not cause the antenna to overload.
- Ensure that any active antenna is calibrated at the internal gain and frequency settings, and measurement distance as intended in use.
- Ensure the coaxial cables connected to the antennas do not influence the test measurement. This may require treatment of the outer shield with ferrite absorbers.

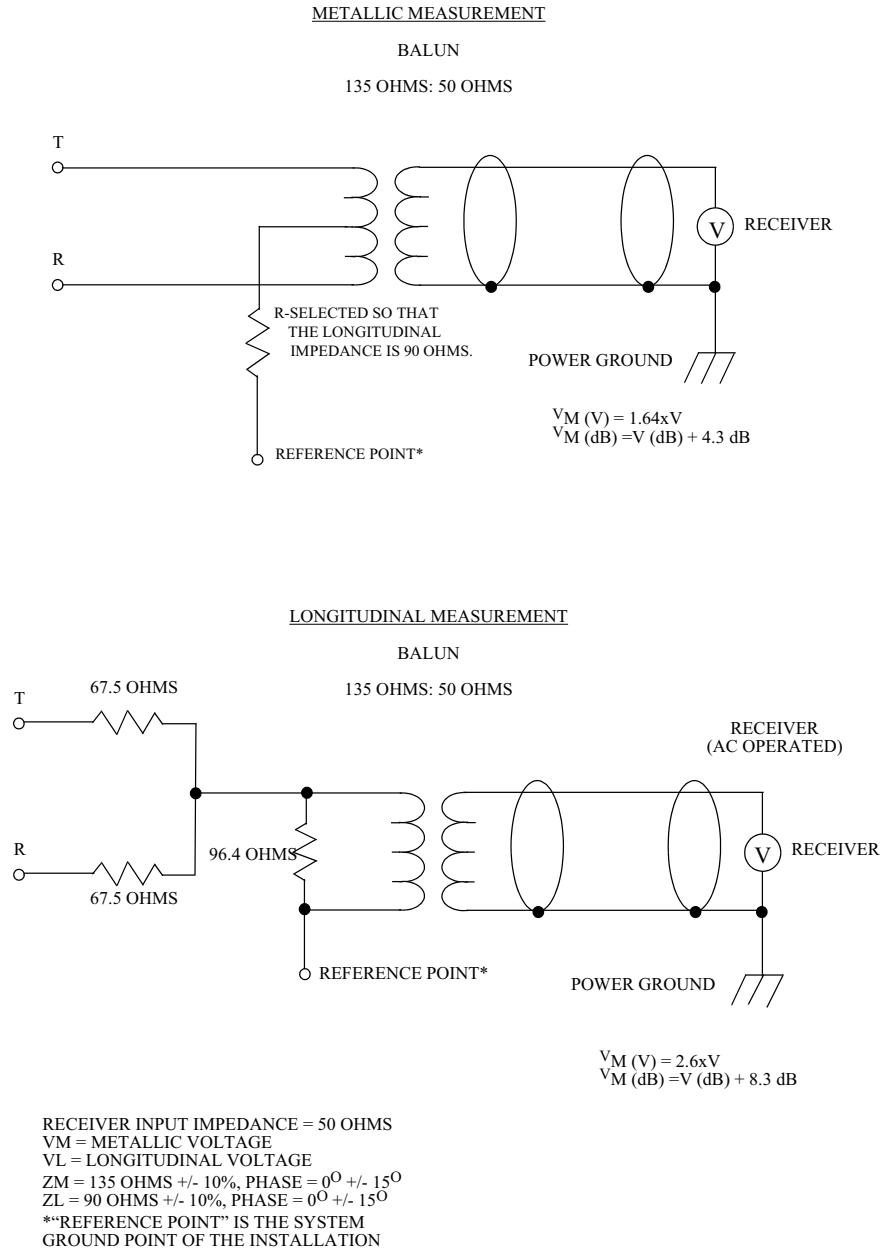


**Figure 3-6 Termination Networks for Conducted Measurements of Analog Voiceband Leads (Metallic and Longitudinal)**



\* "REFERENCE POINT" IS THE SYSTEM GROUND POINT OF THE INSTALLATION

**Figure 3-7 Balun Termination (Metallic and Longitudinal), 12 kHz to 6 MHz**



### 3.4.4 General Test Conditions

#### 3.4.4.1 Emission Measurement Uncertainty

In performing emission measurements, it is important to minimize measurement uncertainties and obtain reliable, repeatable results. Selection of appropriate procedures, instrumentation, and test location is significant in accomplishing these goals. Nevertheless, some uncertainties will remain. To account for them, it is important to allow adequate margin when using the measured data. For example, the measurement errors possible in a shielded enclosure should be accounted for when using measured data obtained in the enclosure. Because spectrum analyzers do not necessarily conform to a recognized standard, care should be exercised when using different analyzers and comparing measurements made with them. On the other hand, the margin allowed should be realistic, since a substantial amount of unnecessary margin results in costly over-design.

#### 3.4.4.2 Testing at an Open-Area Test Site (OATS)

Measurements of radiated radio noise should be made in an open, flat area characteristic of cleared, level terrain that meets the criteria of ANSI C63.4-2003,<sup>[14]</sup> ANSI C63.7-1992,<sup>[20]</sup> and ANSI C63.6-1996.<sup>[21]</sup> Other considerations being equal, the representative systems selected should be the largest available (that is, those with the greatest number of lines and/or trunks) and/or those configured in such a manner that one would expect greater emission levels from them than from other configurations. For example, if system A is slightly smaller than system B, but is composed of many more subsystems known to emit relatively higher levels of signal compared to other types of subsystems, then system A should be selected. If an OATS cannot accommodate a large EUT, the measurement procedure of ANSI C63.4-2003,<sup>[14]</sup> Section 8.1, may be used.

#### 3.4.4.3 Testing at User's Installation (On-Premises Testing)

Testing of a large system may be performed at the end user's premises. However, the test results are typically difficult to interpret, because signals from other nearby RF sources might be confused as emissions from the EUT. The system itself or both the system and its premises in combination may be considered as the EUT. In cases where many similar systems are to be installed, three representative samples of such systems should be tested, each at its end user's premises.

##### 3.4.4.3.1 System Premises

The boundaries of the system premises may be taken as the outside boundaries of the room or building containing the equipment. A Line Impedance Stabilization Network (LISN) should not be used on power ports during radiated emissions testing on-premises so the measured radio noise represents the specific site.

### 3.4.4.3.2 Number of Systems To Be Tested

Three representative samples of a class of systems should normally be tested. If, for all systems tested, no radiated or conducted emission is found to exceed the appropriate limit, all systems within the class similar to the sample tested should be considered to meet the emission limits.

### 3.4.4.3.3 Selection of Systems for Test

#### A. Previously Existing Classes of Systems

For previously existing classes of systems, where many systems are typically available for selection, the factors to be considered in selecting the representative systems for test should include similarity to current manufacturing, measurement accessibility, building construction, system configuration, and size (such as number of lines and/or trunks), and ambient RF environment.

*Similarity to current manufacturing* — The systems selected should represent the systems currently being manufactured. Typically, this means selecting systems that have recently been installed.

*Measurement accessibility* — The systems selected should be accessible for measurement with adjacent structures far enough away to permit testing at an adequate number of radials at the equipment elevation.

*Building construction* — If the measurements are to be made in such a manner that the building containing the system is considered part of the EUT, the systems selected should be such that the buildings housing the systems are representative of the various types of construction that are typically used. If, as a result of other considerations, it is only possible to select systems housed in buildings of construction believed to offer significantly more RF attenuation than the average, then the acceptable level of radiated emissions from those representative samples should be appropriately lowered from the limit. The rationale by which the appropriate limit is reached should be added as part of the data.

*System configuration and size* — Other considerations being equal, the representative systems selected should be the largest available (that is, those with the greatest number of lines and/or trunks) and/or those configured in such a manner that one would expect greater emission levels from them than from other configurations. For example, if system A is slightly smaller than system B, but is composed of many more subsystems known to emit relatively higher levels of signal compared to other types of subsystems, then system A should be selected. For frame- or bay-based equipment, the EUT should consist of the smallest number of fully loaded units necessary for exercising all functions. The pack fill should be selected based on the worst representative combinations of packs required to fulfill the functional specifications.

*Ambient RF environment* — Representative systems should preferably be selected at sites where the RF ambient is expected to be relatively quiet.

## B. New Classes of Systems

For new classes of systems, the first three systems installed are typically selected for on-site testing. This may not always be practical, for example, if one or more of the first three systems is installed on upper floors of office buildings. Where on-premises testing of the first system to be installed is impractical, supporting evidence (that is, measured data taken on subsystems) should be provided to indicate that, in accordance with good engineering judgment, the system to be installed is expected to comply with the emission limits. When this supporting evidence is available, the system may be installed and operated. If, at a later date, it becomes practical to test the system on-premises, it should be tested within a reasonable time following that date, provided a sufficient number of similar systems have not already been tested on-premises for the purpose of verifying compliance of similar systems of its class.

## C. Modified Systems

Systems that were previously tested and are later modified may need to be retested. The conditions for retesting such a system are described in [Section 3.4.7](#).

### 3.4.4.4 Testing in a Shielded Enclosure

Radiated emission measurements made in a shielded enclosure not containing absorber lining may be useful for determining the frequency characteristics of a subsystem and for determining the relative emission levels between similar subsystems. They are not suitable for determining the actual level of the emission because these enclosures may have anomalies that can lead to significant errors.<sup>[14]</sup> Conducted radio noise measurements made in a shielded enclosure are acceptable.

An absorber-lined shielded enclosure may be used to measure radiated emissions above 30 MHz, provided the alternate site meets the site attenuation of ANSI C63.4-2003.<sup>[14]</sup> In cases of disagreement, final radiated emissions tests performed at an open-area test site meeting the requirements of ANSI C63.4-2003<sup>[14]</sup> take precedence. Below 30 MHz, absorber-lined shielded enclosures may be used to measure radiated emissions if it can be shown that the results of tests made in the enclosure can be correlated to those made at an open-area test site.

### 3.4.4.5 Subsystem Emission Limits Allocation

In acquiring supporting evidence of system compliance, as mentioned in [Section 3.4.4.2](#) and [Section 3.4.4.3](#), it may be desirable to test subsystems. To ensure the complete system complies when subsequently tested, the total system radiated emission limits should be allocated among the subsystems. These allocation procedures should be engineered on a system basis (ANSI C63.12).<sup>[22]</sup> Coordination should be maintained across all subsystems so that the occurrence of two or more strong spectral lines within the same 100-kHz bandwidth will be detected and handled appropriately.

#### 3.4.4.6 Units of Measurement

Measurements of radiated emissions may be recorded in terms of microvolts per meter or decibels with respect to 1 microvolt per meter ( $\text{dB}\mu\text{V}/\text{m}$ ) at a specified distance. The indicated readings on the radio-noise meter or the spectrum analyzer should be converted to microvolts per meter or  $\text{dB}\mu\text{V}/\text{m}$  by use of the appropriate conversion factors. Measurements of conducted emissions should be reported in terms of the applicable limit units: decibels with respect to 1 volt; microvolts; decibels with respect to 1 microvolt; microamperes; decibels with respect to 1 microampere.

#### 3.4.4.7 Data Reporting Format

All radiated and conducted emissions above the limits and within 6 dB of the limits shall be reported. If any indicated peaks appear while scanning, readings should be taken at the frequencies where they occur. The scan rate should be such that noise signals from the EUT above the radio-noise meter sensitivity threshold are not omitted from detection.

The measurement results expressed in accordance with [Section 3.4.4.6](#), and specific limits where applicable, shall be presented in tabular or graphic form, or alternatively as recorder charts or photographs of a spectrum analyzer display, showing level versus frequency. Test data shall identify the mode of operation and methods used. Instrumentation (along with calibration dates), instrument attenuator and bandwidth settings, detector function, EUT arrangements, antenna factors, coaxial cable loss between antenna and receiver, sample calculation with all conversion factors, and all other pertinent details should be included along with the measurement results. A photograph of the test setup and the EUT arrangement should be provided for repeatability purposes in the case of retest. The rationale for selecting a particular EUT configuration and load as tending to produce maximized emissions must be documented in the test report. The test report shall also show precisely how all cabling is finally arranged when the measurements are made and shall indicate if any special accessories such as shielded cables or special connectors are used during tests to achieve compliance. The test report must include a detailed list identifying the EUT printed circuit boards tested.

#### 3.4.4.8 Test Conditions for EUT

The EUT should be fully operational, suitably configured, and should be typically loaded production equipment, including hardware, software, and firmware, for application in the networks of the telecommunications service providers. For the purpose of this section, this means that the equipment shall be configured and operated in a manner that tends to maximize its emissions characteristics. Test conditions of the EUT are described in [Section 3.5.3](#).

#### 3.4.4.8.1 EUT Installation

EUTs that are typically mounted in a frame should be installed in a telecommunications equipment frame as shown in [Figure 3-12](#) and described in [Section 3.5.5.3.3](#) during the EMI testing.

If special accessories such as shielded cables or special connectors are used during tests to achieve compliance, a note shall be included in the installation or instruction manual advising of the need to use such accessories as indicated in [R3-1 \[159\]](#).

Leads that penetrate the test chamber should be properly filtered at the bulkhead to reduce leakage into or out of the test enclosure, thereby compromising the integrity of the enclosure and test measurement data. The filter frequency response should not distort relevant signals being used for communication between the EUT and equipment outside the test enclosure. The filter(s) should provide a low-impedance to ground for common-mode signals (at least on the EUT side of the bulkhead) that may flow on the penetrating leads in the frequency range 10 kHz to 10 GHz. Cables used for monitoring or setup purposes (i.e., cables not normally attached to the EUT in a typical installation and operation, as defined in the user manual) are addressed like all other cables with regards to the use of ferrites. For shielded cables, the shield of the cable that exits the chamber shall be bonded to the chamber bulkhead panel (outer wall if more than one wall exists), providing an adequate path to ground.

The use of ferrites must be avoided, except if all of the following conditions are satisfied:

1. Ferrites shall not be used inside the test area, unless the ferrites are a permanent part/component of the EUT. The test area is defined as the area within the faraday cage boundary of the test chamber, or the area within the ellipse of an Open-Area Test Site (OATS). For other test setups, the ferrites shall be located as close as practicable to the auxiliary and/or support equipment.
2. If commercial filters are not available, no additional restrictions apply, provided that there are cables, without ferrites, attached to similar ports of the EUT and passing traffic. Hence, to use this clause, the equipment must have multiple ports of a similar type, using loop-backs (or another EUT) loaded with cables and passing data. At least one of these cables has to be properly routed per [Figure 3-12](#) and not have any ferrites attached. The daisy chain data is ultimately monitored by equipment outside the chamber that may use ferrites on the cable penetrating the chamber.
3. If Item 2 cannot be met and ferrites must be used outside the test area as defined in Item 1, a justification shall be included in the test report explaining the impact of the use of ferrites.

#### 3.4.4.8.2 Conditioning of the EUT

The EUT should be operated for a sufficient period of time before testing to approximate normal operating conditions.

### 3.4.4.8.3 Interfacing Units and Simulators

In case the EUT is required to interact functionally with other units, the actual interfacing units should be used. Alternatively, simulators may be used to provide representative operating conditions, provided the effects of the simulator can be isolated or identified. It is important that any simulator used in lieu of an actual interfacing unit properly represents the electrical, and in some cases the mechanical, characteristics of the interfacing unit. For example, a switching system should be loaded as follows for EMI testing.

- If the EUT principally performs call processing, traffic should be simulated by the use of “load boxes” with a sufficient number of originating and terminating lines and trunks to generate a nominal traffic load equivalent to 50% of the rated call processing capacity of the EUT. A load box is a device that generates actual physical calls on the line and trunk ports of the EUT, exercising all the resources of the EUT that would be used for live traffic. An appropriate call mix (such as dial pulse and dual-tone multifrequency) as given in GR-517-CORE<sup>[9]</sup> is to be carried by the EUT.
- When the EUT is a distributed processing system composed of both central and peripheral processing subsystems, the test load level applies only to the portion of the EUT affected by the particular test. Portions of the EUT that the tester judges to be unaffected by a particular test may be operated at lower load levels for that test. However, all units should be loaded to some extent.
- For high-capacity processing systems, it may be impractical to bring the load on the EUT up to the prescribed level solely with the use of load boxes. In such cases, it is acceptable to provide additional traffic using internal traffic simulation software or other artificial means to increase the call processing load to the prescribed level. However, a minimum of 6000 calls per hour should be provided by the use of load boxes. The capability to detect and report call processing errors in the artificial traffic must be comparable to that for traffic generated by the use of load boxes.
- Other switching system functions such as data transfer, maintenance routines, and AMA should also be on-going during the EMI testing.

As another example, a disk drive or solid-state memory unit shall be reading, writing, and transferring data, and performing any other design-intended functions during the tests.

For systems other than switching systems, the EUT shall be configured, installed and operated in a manner that is consistent with typical applications. Interface cables/loads/devices shall be connected to at least one of each type of interface port of the EUT. All cables including those used for initial installation, setup, or configuration shall be connected. Where practical, each cable shall be terminated in a device typical of actual usage.

All interface cable lengths shall approximate as closely as possible the lengths used in typical installations.

The test program or other means of exercising the equipment shall ensure that the various parts of a system are exercised in a manner that permits detection of all system disturbances during immunity and emissions testing.



#### 3.4.4.8.4 EUT Grounding

The EUT should be grounded in a manner consistent with typical installation of the equipment as declared in [Section 9.3](#) (e.g., as part of an IBN or CBN).

#### 3.4.4.8.5 DC Return

The dc return configuration should be as specified by manufacturer. See [Section 9.8.3](#).

#### 3.4.4.9 Test Environment

The environment at the test site should satisfy the following conditions.

##### 1. Ambient Radio-Noise and Signals

It is desirable that the conducted and radiated ambient radio-noise and signal levels, measured at the test site with the EUT de-energized, be at least 6 dB below the allowable limit of the applicable limit or standard. However, if the measured levels of ambient plus EUT radio noise emissions are not above the applicable limit, the EUT should be considered to be in compliance with the limit.

Where the combined ambient noise and EUT emissions exceed the specified limit at frequencies that the EUT is known to emit, as determined from other measurements (that is, those made in shielded enclosures), any one or more of the four actions listed below may be used to decrease the ambient noise relative to the EUT emissions. When this is done, it shall be demonstrated that, at any measurement frequency, the following two conditions are met:

- a. The ambient noise level is at least 6 dB below the EUT emission plus ambient conditions.
- b. The ambient noise level is at least 4.8 dB below the specified limit, with the limit extrapolated, if necessary, to the actual distance.

Methods listed below may be used to show compliance when testing is done in the presence of high levels of ambient noise.

- Perform measurements at distances closer than required, and extrapolate the results to the required compliance test distance using an inverse distance linear attenuation factor.
- Insert line filters between the power source and the LISN or between the power source and the EUT as appropriate.
- Perform measurements of critical frequency bands during off hours when broadcast stations may be off the air and industrial ambient fields are lower.
- Perform measurements using bandwidths narrower than required and extrapolate the results to the specified bandwidth.

## 2. Temperature

The EUT and the measuring equipment should be within their normal operating temperature ranges. Evidence should be given so that the calibrations of the measuring instruments used are accurate for the temperatures at which they are used.

### 3.4.4.10 Arrangements of EUT

For an EUT located at the user's premises, distances should be measured from the nearest point of the boundary defined by an imaginary straight-line periphery describing a simple geometric boundary that encompasses all EUT components or from the equipment itself, or from the outside of the building if the building is considered part of the EUT. All significant EUT components and interconnecting cabling should be within this boundary. Measurements may be made at the limit distance or at lesser distances and appropriately extrapolated to the limit distance.

### 3.4.4.11 Arrangements of Intentional Radiators

The following arrangements shall be considered during the testing of intentional radiators:

- The EUT shall be tested with the antenna in place or with a termination load that exhibits its characteristic impedance (e.g., 50 ohms) or simulator(s) in place of the antenna.
- The EUT shall be configured to operate at maximum rated RF power.
- The frequency channel of the EUT with the highest output power shall be selected as listed in the FCC test report for this testing.
- The EUT shall be configured to use the modulation type(s) certified in the applicable FCC test report that produces the worst-case radiated spurious emissions.
- The EUT shall be configured to operate in a mode that allows selecting the longest transmitter duty cycle, if applicable.
- The EUT should be arranged similar to unintentional radiators described in this document. If additional guidance on EUT arrangement is required, refer to ANSI C63.4.<sup>[14]</sup>

## 3.4.5 Conducted Emissions Measurements

Testing for conducted emissions may be done at the open-area test site or the user's installation site described in Section 3.4.4. Individual units that directly connect to a commercial ac power line or a dc power line should independently comply with the conducted emission limits.

Measurements of conducted emissions should be made using the measuring instrumentation described in Section 3.4.3. Consistent with Section 3.4.4, the EUT should be set up and operated in a manner typical of actual use.

If the EUT is normally operated with shielded or armored leads, the tests should be made using such leads. Equipment normally used with unshielded power leads should be connected to the LISN and tested with unshielded leads.

### 3.4.5.1 Measurement Procedures

#### 3.4.5.1.1 AC Power Ports (Voltage)

Refer to test set up of Clause 9 in CISPR 22<sup>[23]</sup> using for measurement the appropriate Artificial Mains Networks (AMNs) specified in Clause 4.1 of CISPR 16-1-2.<sup>[18]</sup>

Alternatively, refer to test set up of Clause 7 in C63.4-2003<sup>[14]</sup> using for measurement the appropriate Line Impedance Stabilization Network (LISN) specified in Clause 4.1.2 of C63.4-2003.<sup>[14]</sup> Figure 2 of C63.4-2003<sup>[14]</sup> specifies a LISN for the frequency range from 150 kHz to 30 MHz.

#### 3.4.5.1.2 AC Power Ports (Current)

The phase and neutral leads of the ac power port should be connected as shown in Figure 3-8 using a LISN having an impedance characteristic within the limits shown in Figure 1 in C63.4-2003.<sup>[14]</sup> A current probe with sufficient frequency response should be placed around the phase lead and neutral lead simultaneously, with the output of the current probe fed into the measuring instrument. The current probe should be located approximately 1 meter from the EUT. At very low frequencies, it may be necessary to turn off the EUT to determine the source of significant emissions. Measurements of conducted current emissions should be reported in terms of microamperes or decibels with respect to 1 microampere.

#### 3.4.5.1.3 DC Power Ports (Current)

The supply and return leads of the dc power input cables and, if applicable, dc power output cables should each be connected as shown in Figure 3-8 using a LISN having an impedance characteristic within the limits shown in Figure 1 in C63.4-2003.<sup>[14]</sup> Both supply and return leads should be connected to a LISN that presents the appropriate impedance for the 10 kHz to 30 MHz measurement range. A current probe with sufficient frequency response should be placed around both the supply and return leads simultaneously with the output of the current probe fed into the measuring instrument. The current probe should be located approximately 1 meter from the EUT.

#### 3.4.5.1.4 Telecommunications Ports - Signal Leads

The signal leads of the EUT should be connected to their actual terminations if possible as shown in [Figure 3-9](#). Alternatively, simulated terminations with the same RF characteristics may be used. A current probe with sufficient frequency response should be placed around the signal leads associated with each kind of port of the EUT, with the output of the current probe fed into the measuring instrument. Each kind of port shall be tested individually. Where the EUT has one or more identical ports, at least one of each kind of port shall be tested.

If the EUT is normally operated with shielded or armored leads, the current probe should be placed around the entire shielded cable. The current probe should be located approximately 1 meter from the EUT.

#### 3.4.5.1.5 Telecommunications Ports - Analog Voiceband Leads

Voiceband circuits should be tested using the measuring instrumentation described in [Section 3.4.3.2](#).

Following are two procedures to measure conducted emissions on analog voiceband leads. The first procedure (narrowband measurement procedure) is the more accurate procedure; it should be used to determine if the requirement limits are met when the second procedure (broadband measurement procedure) indicates that the levels are close to the limit. The broadband measurement procedure may be used to acquire preliminary data; it requires less time than the narrowband measurement procedure. When the emissions are below the most restrictive limit specified for the particular frequency range when measured with the broadband measurement procedure, the signal levels in each of the 8-kHz bands in that frequency range will be lower than the specified requirement. However, the narrowband procedure should be used when the limit is not met when measured with the broadband measurement procedure. The EUT might then meet the limit, because the signal level in each 8-kHz band may be acceptable.

The measurement should be performed with the termination network simulating the on-hook and off-hook states of customer premises equipment. The on-hook state is simulated by inserting two capacitors in series with the input leads of the termination network. See [Section 3.4.3.2.2](#).

When using a frequency-selective meter that measures in discrete bands, rather than a true swept measurement, the following procedure should be used.

Total the voltages that are within 6 dB of the specified limit in any two consecutive bands. If the sum of these voltages fails the limit, then recheck the measurement at a frequency centered over the band with the failure.

The total RMS voltage can be calculated using the expression

$$V_t = \sqrt{V_1^2 + V_2^2}$$

where  $V_t$  is the total RMS voltage, and  $V_1$  and  $V_2$  are the voltages within 6 dB of the specified limit in two consecutive bands.

If a spectrum analyzer is used and it does not have an 8-kHz bandwidth, a 10-kHz bandwidth may be used. Application of correction factor, additional measurements, or both may be required to compensate for the wider bandwidth.

If a 10-kHz bandwidth is used, and a failure condition is noted, it may be necessary to check that reading, using a higher resolution, if the spectral content has an uneven distribution.

The total RMS voltage over an 8-kHz band can be calculated using the expression

$$V_t = \sqrt{V_1^2 + V_2^2 + V_3^2 + \dots V_n^2}$$

where  $V_t$  is the total RMS voltage over any 8-kHz band and  $V_1, V_2, V_3, \dots V_n$  are the spectral components within that band that are within 20 dB of the limit band in question.

If the spectral content of a band is evenly distributed, then the equivalent RMS power in an 8-kHz band can be found by subtracting 1 dB from the measured power using a 10-kHz bandwidth.

#### A. Narrowband Measurement Procedure

Connect the analog voiceband leads of the EUT to the appropriate termination network for each test as shown in [Figure 3-10](#).

- 4 kHz to 270 kHz

With the frequency-selective meter, measure the power of each of the 8-kHz bands in the frequency range from 4 kHz to 270 kHz. Record the highest emissions in each frequency band of the limit (4 to 16 kHz, 8 to 94 kHz, and 86 to 270 kHz for metallic measurements, and 4 to 16 kHz, 8 to 46 kHz, and 38 to 270 kHz for longitudinal measurements).

- 270 kHz to 6 MHz

Insert the bandpass filter (270 kHz to 6 MHz) between the termination network and the frequency-selective meter (see [Figure 3-10](#)). Set the meter to measure broadband power in the frequency range 270 kHz to 6 MHz. Measure and record the emission level in dBVrms.

#### B. Broadband Measurement Procedure

Connect the analog voiceband leads of the EUT to the appropriate termination network for each test as shown in [Figure 3-10](#).

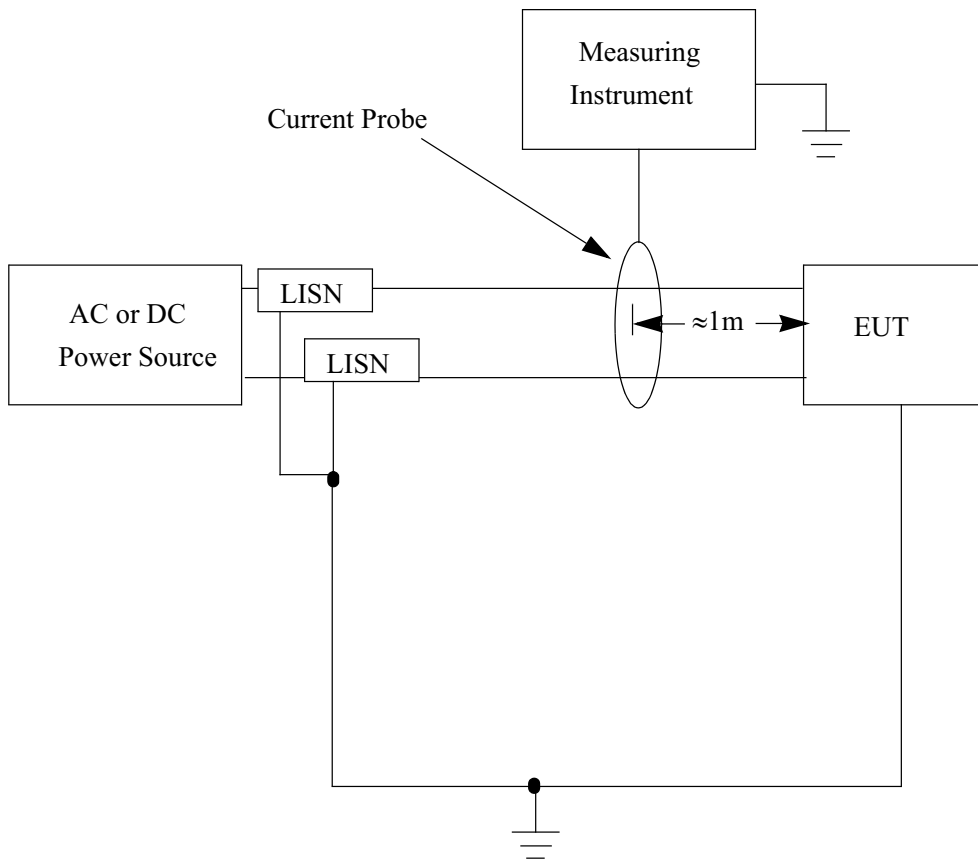
Set the passband of the bandpass filter to measure broadband power in each of the bands of interest (4 to 16 kHz, 8 to 94 kHz, 86 to 270 kHz, and 270 kHz to 6 MHz for metallic measurements, and 4 to 16 kHz, 8 to 46 kHz, 38 to 270 kHz, and 270 kHz to 6 MHz for longitudinal measurements). Record the highest emission in each frequency band of the limit. If all test results meet the criteria over each frequency range, then no further test is required. If the limits are not met, then employ the narrowband procedure for a partial or complete retest.

### 3.4.5.1.6 Telecommunications Ports - Telecommunications Leads

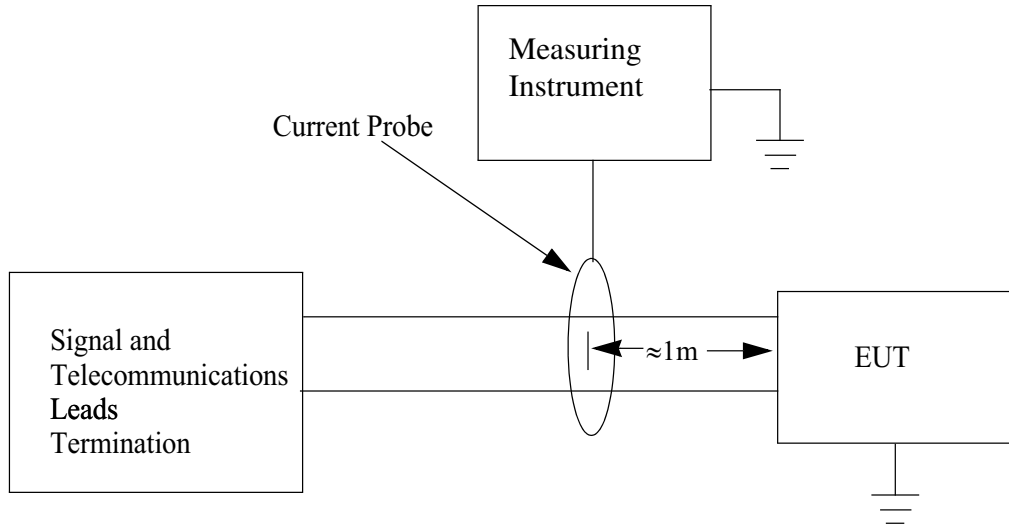
Telecommunications circuits should be tested using the measuring instrumentation described in Section 3.4.3.3.

The telecommunications leads of the EUT should be connected to their actual terminations as shown in Figure 3-9. A current probe with sufficient frequency response should be placed around the entire shielded cable of telecommunications leads, with the output of the current probe fed into the measuring instrument. The current probe should be located approximately 1 meter from the EUT as shown in the test setup of Figure 3-9.

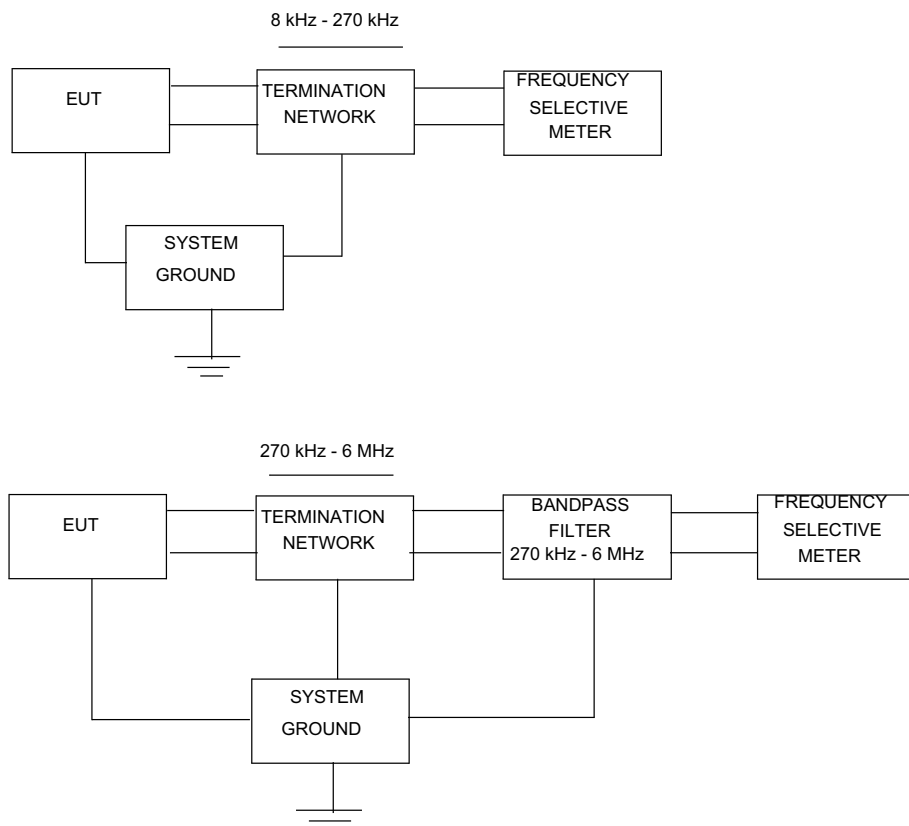
**Figure 3-8** Test Setup for Conducted Emission Tests on AC and DC Power Ports (Current)



**Figure 3-9** Test Setup for Conducted Emission Tests on Signal and Telecommunications Leads



**Figure 3-10** Test Configuration for Measuring Conducted Emissions From Analog Voiceband Leads



### 3.4.6 Radiated Emission Measurements

Measurements of radiated emissions should be made using the measuring instrumentation and antennas described in Section 3.4.3. Radiation from the EUT including all cabling shall be measured. Consistent with Section 3.4.4, the EUT should be set up and operated in a manner typical of actual use.

#### 3.4.6.1 Determination of Test Radial

If there is no *a priori* knowledge concerning the directional nature of the radio noise emissions from the EUT, a radiated emissions prescan of the EUT shall be made. Frequency scans of the EUT radiated emissions should be made at as many azimuth angles as is necessary and practical at the installation site in characterizing the EUT emanation profile. For radiated emissions prescans, the EUT shall be rotated 360 degrees so that emissions from all sides of the EUT are recorded. If the turntable is stepped instead of continuously rotated the maximum step size shall be 45 degrees. antenna heights of 1 and 2 meters shall be used during the radiated emissions prescan procedure. Emissions prescans shall be made in both horizontal and vertical polarizations from 30 MHz to 10 GHz. However, if the directional noise patterns are known (such as from measurements made on similar systems in similar buildings or azimuth information is available from the prescan), then it is acceptable to examine only a small number of radials in the vicinity of the known significant directions. The measuring instrument and test antenna should be moved around the EUT (or rotate the EUT) to determine the direction of maximum field strength for each predominant emission. At each azimuth, the antenna should be raised as indicated in Section 3.4.3.6. Measurements should be made at the azimuth so that the maximum radiation levels are detected in both the horizontal and vertical planes of polarization.

#### 3.4.6.2 Radiated Radio Noise Tests

An EUT subjected to a radiated limit at 10 meters may be measured at a different distance provided the results are appropriately extrapolated and documented along with the rationale used. If possible, measurements should be made at a distance at least as great as the largest dimension of the EUT. For electric field measurements above 30 MHz, the center of the antenna should be varied in height between 1 and 4 meters above the EUT floor elevation to determine the maximum level of emission. Notwithstanding the height range just given, the minimum antenna height for each frequency and polarization should be limited so that no element of the receiving antenna is less than 25 centimeters from any reflecting surface. At sites other than open-area test sites, it is permissible to replace continuous variation of antenna height with setting the antenna at one or more fixed heights provided that it can be shown that equivalent results are obtained. For magnetic field measurements, the antenna shall be positioned in the coaxial (loop parallel) and planar (loop perpendicular) orientations at the specified distance from the EUT. The center of the loop shall be 1 meter above the ground plane.



Both horizontal and vertical polarization of the search antenna should be used and all emissions within 6 dB of the appropriate limit shall be recorded. The LISN, if installed for the power line conducted radio-noise measurements, may be left in place for the radiated emission tests unless the emissions measurement is made at the user's installation. A LISN should not be used on power leads during radiated emissions testing on-premises so the measured radio noise represents the specific site.

### 3.4.7 Retesting With System Evolution and Growth

If a system or class of systems previously tested and found to be in compliance is modified either by changing existing equipment or adding new equipment such that the possibility for significantly increased radiated and/or conducted emissions and decreased radiated and/or conducted immunity exists, retesting may be necessary as determined in the following text.

#### 3.4.7.1 System Evolution

For changes to a system or class of systems that, in accordance with good engineering judgment, are not considered likely to increase the emissions above the applicable limit or decrease the system immunity, retesting is unnecessary. However, some changes to subsystems may require retesting as follows.

##### 1. New Subsystems

If a new subsystem (that is, one not similar to any other existing subsystem) is to be installed as part of an existing system, the new subsystem with its associated cabling and terminations should be tested individually for radio-noise emissions and immunity before it is placed in service. If, in accordance with good engineering judgment, the addition of the new subsystem is considered as possibly increasing the emissions or decreasing the immunity of the system significantly, the resultant system should be retested for compliance with the radio-noise emission and immunity limits.

##### 2. Existing Subsystems

For changes to a system or class of systems that are considered as possibly increasing the emissions or decreasing the immunity significantly, the modified system or a representative sample of the modified class of systems should be retested or, alternatively, it is acceptable to analyze only the particular subsystem that was modified. The radiated emission and immunity analyses may be accomplished by comparing the emissions and immunity from the modified subsystem with those from the unmodified subsystem. If the emissions and immunity from the modified subsystem are less than or equal to those of the unmodified subsystem or greater than those of the unmodified subsystem by amounts that when added to the original system emissions do not exceed the emission limits, the overall modified system or class of systems can be considered as compliant.

### 3.4.7.2 System Growth

This section applies to subsystems that are to be added to a system and that may add significant emissions or reduce immunity to the overall system. If a number of subsystems are to be added to a system that already contains some number of similar subsystems, an analytical rationale may be used to verify that the final system complies with the emission and immunity limits. The analytical rationale should be documented along with the data used. If the analytical rationale shows that the altered system may exceed the compliance limits, the final system should be tested or retested for compliance with the radiated and conducted emission and immunity limits.

## 3.5 Measurement Procedures Associated With Immunity

### 3.5.1 Scope

This section sets forth measurement procedures to be used for determining whether an EUT meets the immunity criteria in [Section 3.3](#). The methods are intended to provide a common basis for evaluating an EUT relative to the immunity criteria.

### 3.5.2 Measuring Instrumentation

#### 3.5.2.1 Receivers

The measuring instrument, its calibration, and its detector function should be as required in [Section 3.4.3](#) for the applicable frequency ranges.

#### 3.5.2.2 Current Probes

Any current probe capable of measuring to the limits in this section, conforming to CISPR Publication 16-1,<sup>[18]</sup> may be used. The probe used should have adequate insulation to prevent direct conduction from the leads under test.

#### 3.5.2.3 Antennas

The following antennas should be used for radiated immunity measurements.

1. 10 kHz to 20 MHz

Fields for immunity measurements should be radiated using a parallel line radiator, terminated loop E-field-generating antenna, or Transverse Electromagnetic (TEM, or Crawford) cell. Other antennas that can generate the test signal may be used.

## 2. 20 MHz to 200 MHz

Fields for immunity measurements should be radiated using a biconical antenna. Other linearly polarized antennas as well as a TEM cell may be used.

## 3. 200 MHz to 1 GHz

Fields for immunity measurements should be radiated using a log-periodic antenna or other linearly polarized antenna. A conical logarithmic spiral antenna may be used provided that the horizontal and vertical components of the fields radiated reach magnitudes at least equal to the limits.

## 4. 1 GHz to 10 GHz

Immunity measurements should be performed using a log-periodic or horn (such as a ridged-guide) antenna. Other linearly polarized antennas may also be used. Additionally, a conical logarithmic spiral antenna may be used, provided that the horizontal and vertical components of the fields reach magnitudes at least equal to the limits.

### 3.5.2.4 Signal Sources

Any commercially available signal sources, amplifiers, and/or oscillators/synthesizers capable of developing the required test signal levels may be used, provided their frequency accuracy is within 1% and their harmonic and spurious outputs do not exceed a level of 15 dB below the power of the fundamental frequency.

### 3.5.3 Test Conditions for EUT

Test conditions of the EUT should be as required in [Section 3.4.4.8](#). The traffic loading equipment and monitoring equipment must be immune to the test signals.

If a degradation in performance occurs during the immunity sweep, the frequencies where the degradation occurred shall be recorded. An additional test shall be performed at each recorded frequency with 1-minute dwell time. If a degradation occurs over a continuous band of frequencies, it is acceptable to perform the 1-minute dwell at both ends of the band and the most susceptible frequency in the band. If no performance degradation occurs during the dwell at each frequency, the EUT has met the criteria at that frequency.

The parameters in [Sections 3.5.3.2, 3.5.3.3, and 3.5.3.4](#) should be monitored during the immunity testing of switching systems and other EUTs where applicable.

#### 3.5.3.1 Non-Switching Systems

For systems other than switching systems, the EUT shall be configured, installed and operated in a manner that is consistent with typical applications. Interface cables/loads/devices shall be connected to at least one of each type of interface port of the EUT. Where practical, each cable shall be terminated in a device typical of actual usage.

The test program or other means of exercising the equipment shall ensure that the various parts of a system are exercised in a manner that permits detection of all system disturbances during immunity testing.

### 3.5.3.2 Bit Error Rate (BER)

During the immunity testing, the Bit Error Rate (BER) should be tested for digital systems. The performance criteria are given in the applicable Telcordia Generic Requirements, national and international standards. For example, one DS1 (1.544 Mb/s) line should be tested for BER limits as specified in GR-507-CORE, *LSSGR: Transmission, Section 7*.<sup>[24]</sup> Monitoring of the BER should be performed by testing a looped back (outgoing line connected to incoming line) DS1 (1.544 Mb/s) line for BER.

### 3.5.3.3 Synchronization

During immunity testing, the synchronization of the EUT should be tested. [Figure 3-11](#) illustrates the test configuration that can be used to calculate the synchronization accuracy of a DS1 (1.544 Mb/s) signal, by comparing its extracted timing signal against, preferably, a local cesium primary frequency standard (other appropriate high-accuracy primary frequency standards may be used). This test measures the relative phase accumulation between the input and output signals. Therefore, it is equally valid to use a high-quality frequency standard source that meets the EUT clock specifications. The EUT is synchronized to the same local cesium primary frequency standard. The clock extractor in [Figure 3-11](#) is used to extract an all-ones unipolar 1.544 MHz clock signal from the DS1 (1.544 Mb/s) signal being tested. This clock signal is connected to channel 1 of the oscilloscope. The cesium standard is used to reference a frequency synthesizer, which in turn generates an all-ones unipolar 1.544-MHz clock signal. This signal is connected to channel 2 of the oscilloscope. Phase variations between the two 1.544-MHz signals are recorded on the storage oscilloscope.

The Maximum Time Interval Error (MTIE) objective is 100 nanoseconds during any single immunity signal sweep of less than 30 minutes duration (observation period). See GR-1244-CORE, *Clocks for the Synchronized Network: Common Generic Criteria*.<sup>[25]</sup>

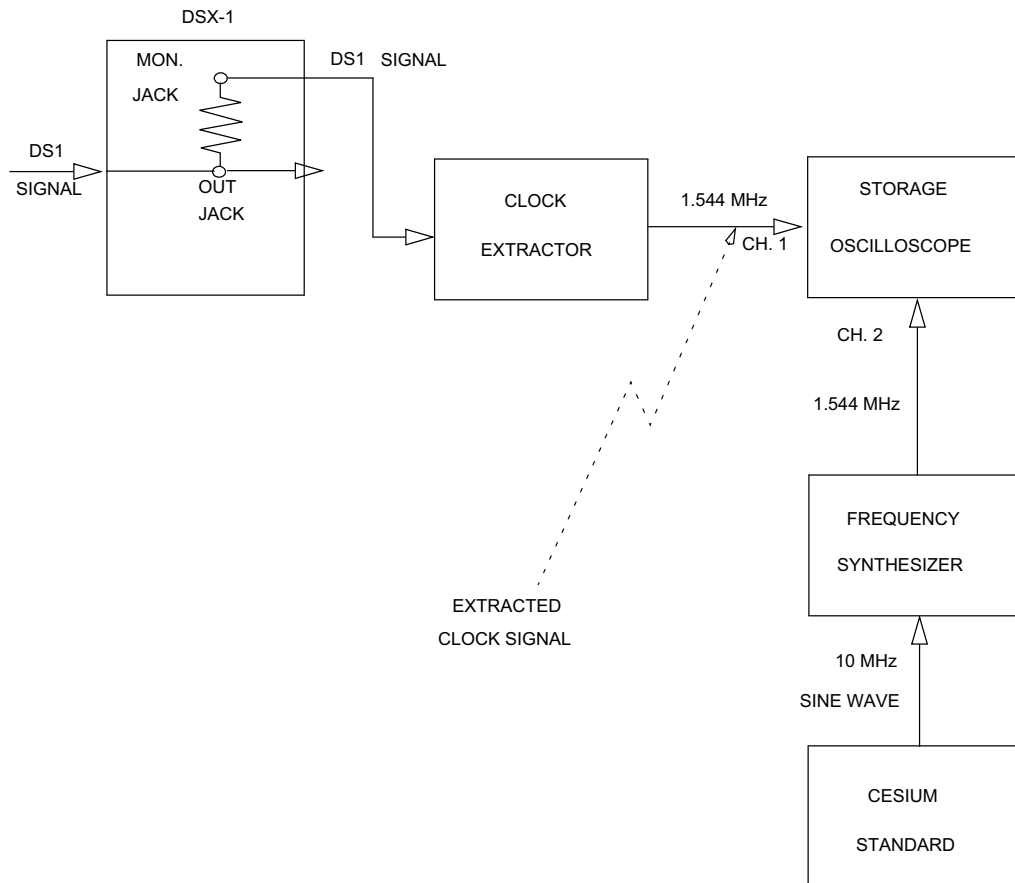
During immunity testing, the test-signal generator should be synchronized to the same local cesium primary frequency standard as that used for synchronizing the EUT.

### 3.5.3.4 Voiceband Noise

During immunity testing, the C-message-weighted noise on tip and ring should be monitored with a transmission test set. All types of voiceband circuit cards should be monitored, including trunk circuits.

A maximum of 20 dBrnC is the requirement for idle-channel noise level, and 16 dBrnC is the objective idle-channel noise level for voiceband circuits as specified in GR-507-CORE<sup>[24]</sup> when measured into a quiet termination. Idle-channel noise levels for other connections are also specified in GR-507-CORE.<sup>[24]</sup>

**Figure 3-11 Synchronization Test Configuration**



### 3.5.4 Data Reporting Format

The format for reporting test data should be in accordance with that given in Section 3.4.4.7. Also, the report shall include the immunity threshold level (that is, field strength or current level) presented in a matrix whose columns designate the alarms and malfunctions and whose rows designate the frequency at which they occurred.

## 3.5.5 Radiated Immunity Measurements

### 3.5.5.1 Shielded Enclosures

Radiated immunity testing should be performed in a shielded enclosure. Otherwise, the fields developed may be strong enough to interfere with other electronic equipment in the vicinity. Furthermore, in the U.S., approval by the FCC would be required to generate fields of the levels required for testing if the measurements were performed at or in test facilities that were not adequately shielded. Depending on the size of the EUT and the frequency range being considered, the shielded enclosure used may be either an absorber-lined shielded room or a TEM (Crawford) cell, see [Section 3.5.5.3.1](#).

### 3.5.5.2 Subsystem Testing

The large size of a switching system may preclude testing the entire system in a shielded enclosure. Additionally, generation of a uniform field over the volume of an entire system may be difficult to accomplish. As such, radiated immunity testing may be done on a subsystem basis with each subsystem having the entire system criteria as its own. Only one representative system need be tested for compliance with the limits.

### 3.5.5.3 Measurement Procedures

#### 3.5.5.3.1 EUT and Antenna Positioning

##### A. Absorber-Lined Shielded Room

The distance between the absorber material and the closest point of the EUT or any element of the field-generating antenna should not be less than approximately 1 meter. If possible, the field-generating antenna should be located at a distance from the EUT at least as great as the largest dimension of the EUT, but no less than 1 meter in any case. The center of the antenna should be aligned with the approximate center of the face of the EUT. When a large EUT is to be immersed in a field, the transmitting antenna shall be placed at a sufficient distance to allow the entire EUT to fall within the 3-dB beamwidth of the transmitted field. If this is not feasible because of difficulty in generating the required field at the greater distance, or because of the nature of the antenna radiation characteristics, the EUT may be tested in segments. Each segment should be equal in dimension to the 3-dB beamwidth of the antenna radiation characteristic. When a linearly polarized antenna is used, it should be positioned so as to generate vertical and horizontal fields in separate tests. The electromagnetic field in the volume of space that the EUT will occupy should be measured (with the EUT removed) to verify that it is reasonably homogeneous. The field homogeneity determination procedure of IEC 61000-4-3<sup>[26]</sup> may be used.

## B. TEM Cell

While either the upper or lower half of the cell may be used, the EUT should normally be placed in the lower half of the cell so that the floor rather than the septum (center conductor) supports the EUT. Within the lower half of the cell, the EUT should typically be placed in one of two locations. The first location is such that the center of the EUT is at the center of the space within the lower half of the cell. Dielectric material with a dielectric constant as close as possible to that of air should be used to support the EUT. The second location for the EUT is on the floor of the cell and centered with respect to the cell floor. The EUT should be insulated from the cell floor. The field needs to be corrected near the cell floor as a result of the field gradient that occurs away from the center of the test volume. In either location, the EUT should be oriented as it would be during normal operation. If practical, testing should also be done with the EUT rotated 90 degrees about its axes so as to effect changes of polarization in three planes.<sup>[27]</sup>

### 3.5.5.3.2 Calibration of Generated Fields

Following are two procedures to calibrate the generated field. The first procedure consists of placing a monitoring antenna at the intended EUT location and recording the power or voltage driving the field-generating antenna to obtain the field strength desired. Additional antenna locations can be selected to determine field variations in the test volume. When the monitoring antenna is replaced by the EUT, the same voltage or power is used to drive the field-generating antenna.

The second procedure consists of placing one or more small field probes near the face of the EUT. The output of the field probe, or the minimum output if more than one probe is used, can then be used to monitor the generated field. Power amplifier output adjustments can then be made to obtain the desired field strength. If this procedure is used, care should be exercised in interpreting the results, since the field is being monitored at only a small portion of the test volume and measurements are being made in the near field of the scattered field from the EUT. The strength of this field at the probe can be greater than that generated by the test antenna, which could then lead to incorrect results.

Alternatively, the field homogeneity procedure called out in IEC 61000-4-3<sup>[26]</sup> from 80 MHz to 6000 MHz may be used for the frequencies between 80 MHz and 6000 MHz. For the frequencies outside this range, use one of the above procedures for calibrating the electric field.

### 3.5.5.3.3 EUT Leads

The EUT power and telecommunications leads should be, as nearly as possible, of the same length, orientation, and termination as they are in their normal operational configuration. If special accessories such as shielded cables or special connectors are used during tests to achieve compliance, a note shall be included in the installation or instruction manual advising the need to use such accessories.

All leads, including performance monitoring leads that are not transparent to the generated field, should be carefully routed inside the shielded enclosure to obtain reliable, repeatable results. EUTs that use overhead cable trays or suspended ceilings to route cables should be tested with cables above and to the sides of the EUT, as shown in [Figure 3-12](#), to simulate a typical installation. The trays or ceiling used during the testing should be typical of an installation. Leads that are not present during normal operation of the EUT should be shielded and routed along areas of low field strength (usually the ground plane), since they may cause erroneous indications of immunity conditions or provide a direct path to sensitive circuits. The shields should be in electrical contact with the enclosure walls and should be routed to the EUT as close to a ground plane as possible. They should not contact the case of the EUT unless a common ground between the EUT and test chamber is desired. If at all possible, optical fiber techniques should be used. The EUT and all cables shall be insulated from the ground plane by up to 12 mm of insulating material as shown in [Figure 3-12](#).

Leads that penetrate the test chamber should be properly filtered at the bulkhead to reduce leakage into or out of the test enclosure, thereby compromising the integrity of the enclosure and test measurement data. The filter frequency response should not distort relevant signals being used for communication between the EUT and equipment outside the test enclosure. The filter(s) should provide a low-impedance to ground for common-mode signals (at least on the EUT side of the bulkhead) that may flow on the penetrating leads in the frequency range 10 kHz to 10 GHz. Cables used for monitoring or setup purposes (i.e., cables not normally attached to the EUT in a typical installation and operation, as defined in the user manual) are addressed like all other cables with regards to the use of ferrites. For shielded cables, the shield of the cable that exits the chamber shall be bonded to the chamber bulkhead panel (outer wall if more than one wall exists), providing an adequate path to ground.

The use of ferrites must be avoided, except if all of the following conditions are satisfied:

1. Ferrites shall not be used inside the test area, unless the ferrites are a permanent part/component of the EUT. The test area is defined as the area within the faraday cage boundary of the test chamber, or the area within the ellipse of an OATS. For other test setups, the ferrites shall be located as close as practicable to the auxiliary and/or support equipment.
2. If commercial filters are not available, no additional restrictions apply, provided that there are cables, without ferrites, attached to similar ports of the EUT and passing traffic. Hence, to use this clause, the equipment must have multiple ports of a similar type, using loop-backs (or another EUT) loaded with cables and passing data. At least one of these cables has to be properly routed per [Figure 3-12](#) and not have any ferrites attached. The daisy-chain data is ultimately



monitored by equipment outside the chamber that may use ferrites on the cable penetrating the chamber.

3. If Item 2 cannot be met and ferrites must be used outside the test area as defined in Item 1, a justification shall be included in the test report explaining the impact of the use of ferrites.

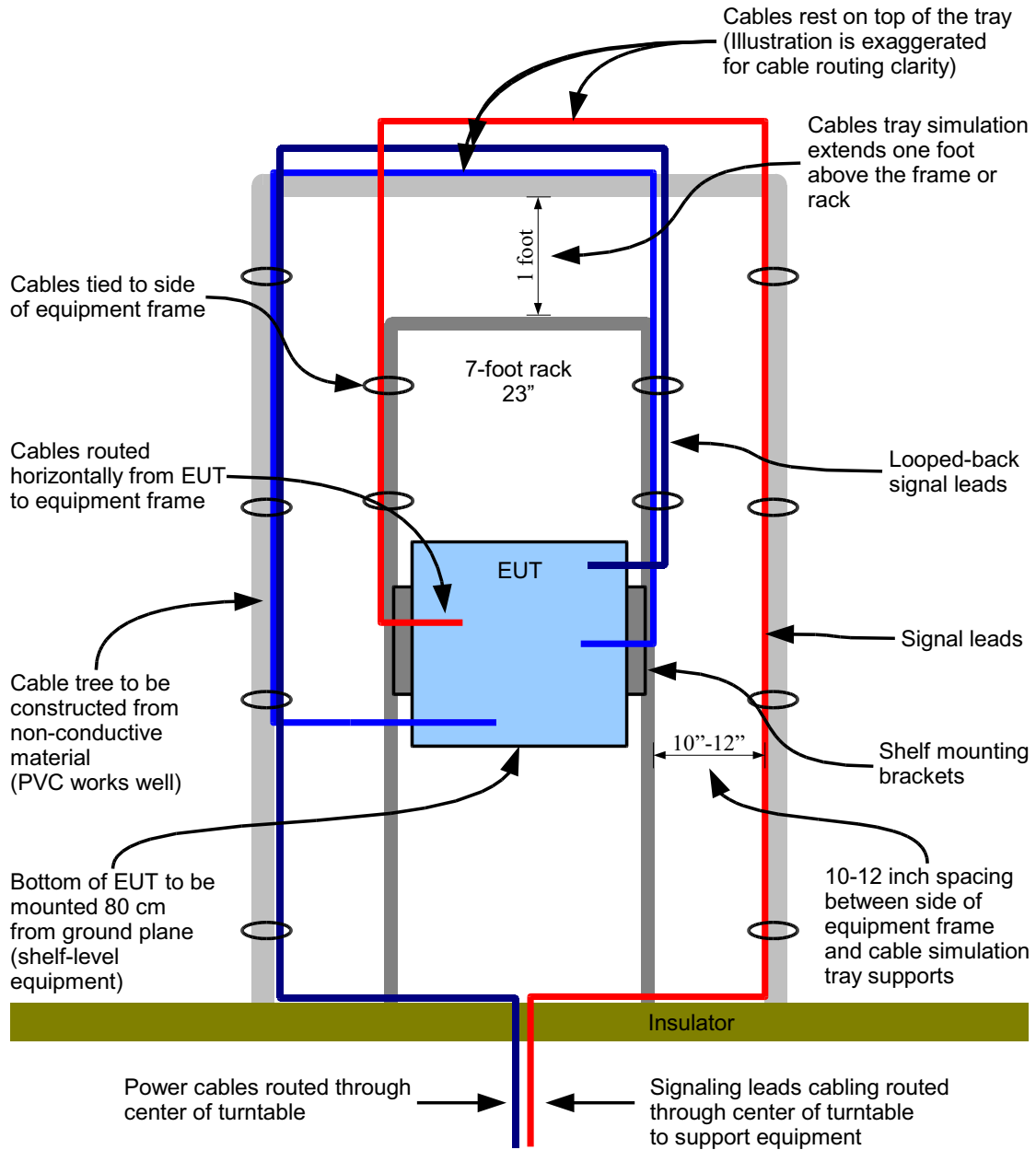
#### *3.5.5.3.4 EUT Grounding*

The EUT should be grounded in a manner consistent with typical installation of the equipment as described in [Section 9.3](#) (e.g., as part of an IBN or CBN).

#### *3.5.5.3.5 DC Return*

The dc return configuration should be as specified by manufacturer. See [Section 9.8.3](#).

**Figure 3-12** Cable Arrangement for EUTs With Overhead Cables



### 3.5.5.3.6 Test Signal Modulation

The calibration levels in Section 3.3.1 are the value of the unmodulated test signal over the frequency range of 0.01 through 10,000 MHz. During the test, the test signal should be modulated, and as a general guideline, it should be modulated to represent the signal in the environment that is most likely to interfere with the EUT. Systems are typically most susceptible to interfering signals of the same modulation. For digital equipment, a pulse modulated test signal that simulates the EUT clock signals should be an effective interfering signal. For the case where AM radio stations are expected to be the primary concern, the test signal should be 80% amplitude modulated with a 1-kHz tone.

In general, for frequencies in the range of 10 kHz to 1 GHz, the test signal should be 80% amplitude modulated with a 1-kHz tone. For the frequency range of 1 GHz to 10 GHz, the test signal should be pulse modulated with the modulating signal having a 0.1- $\mu$ s pulse rise time, a 1- $\mu$ s pulse width, and a 1-kHz pulse repetition rate.

### 3.5.5.3.7 Frequencies and Amplitudes To Be Measured

The entire specified frequency range for each applicable immunity test should be scanned. For analog scan frequencies from 10 kHz to 1 GHz, the IEC 61000-4-3<sup>[26]</sup> ( $1.5 \times 10^{-3}$  decade/s or slower) should be used. For stepped scan frequencies from 10 kHz to 1 GHz, the IEC 61000-4-3 1% step size should be used. For scan frequency from 1 to 10 GHz, frequency scan rates and frequency step sizes of signal sources should not exceed the values listed in Table 3-14. The rates and step sizes are specified in terms of a multiplier of the tuned frequency ( $f_o$ ) of the signal source. Analog scans refer to signal sources that are continuously tuned. Stepped scans refer to signal sources that are sequentially tuned to discrete frequencies. Stepped scans should dwell at each tuned frequency for a minimum of 1 second. Scan rates and step sizes should be decreased when necessary to permit observation of a response.

**Table 3-14** 1 to 10 GHz Immunity Scan Rate and Step Size

Frequency Range	Analog Scans Maximum Scan Rates	Stepped Scans Maximum Step Size
1-8 GHz	$0.002 f_o/\text{sec}$	$0.001 f_o$
8-10 GHz	$0.001 f_o/\text{sec}$	$0.0005 f_o$

A suggested procedure for covering the amplitudes and frequencies to be measured is given in the following text.

The test level should initially be set at the criteria limit. In a frequency range where the limit varies with frequency, the smallest value of test signal strength in that frequency range should be selected as the test level for the initial frequency sweep. Larger values of test signal strength, up to the maximum criteria limit in the frequency range being considered, should be successively tried to decrease the probability that the EUT will be damaged before the test signal can be removed. The frequency should be swept until the performance monitor indicates that the EUT is

no longer performing properly or until the end of the frequency range to be scanned has been reached. When a frequency is encountered at which the EUT no longer performs properly, the frequency scan should be stopped and the applied test signal reduced to zero. The test signal should then be slowly brought up manually, allowing sufficient time for the EUT to respond, until the EUT once again fails to perform properly. The indicated strength of the test signal (immunity threshold) and corresponding frequency should be recorded. If the immunity threshold is significantly different from the strength of the applied test signal during the preceding frequency scan, the rate at which the frequency is being swept may be too fast and the test should be repeated at a slower sweep rate. All pertinent test data should be recorded in accordance with Section 3.5.4, along with a description of the performance degradation observed.

The test signal level should then be set back to the level being applied before frequency scanning was stopped. The frequency of the test signal should be offset slightly in the direction in which the frequency was swept and frequency sweeping should be resumed. For each case where the EUT fails to perform properly, the frequency, immunity threshold, and description of the performance degradation observed should be recorded. Also, the EUT should be tested at the discrete frequencies shown in Table 3-15 for a period of at least 1 minute at each frequency.

**Table 3-15** Frequencies of Key Interest

Service Band	Frequency (MHz)
LORAN C	0.1
AM Broadcast	0.772, 1.54
Amateur Radio	4, 14.2
Citizens Band (CB)	27
Television Channel 2	55.25
FM Broadcast	100
Police and Fire Radio	155.52
Television Channel 11	199.25
Business	466.55
Television Channel 52	699.25
Cellular Telephone	825
PCS	914, 1800
ISM, Bluetooth	2450
ISM, Spread Spectrum	5800
Public Service (Common Carrier)	6197.2
EUT Clock Frequencies	Frequencies depend on particular equipment

### 3.5.6 Conducted Immunity Measurements

Individual units that connect directly to a commercial ac power line or a dc power line should independently comply with the conducted immunity requirements.

The following measurement procedures should be used for testing conducted immunity of telecommunications ports and ac and dc power ports.

### 3.5.6.1 Test Signal Modulation

During the conducted immunity test, the test signal should be modulated in accordance with [Section 3.5.5.3.6](#).

### 3.5.6.2 Frequency Scanning and Test Selection

During the conducted immunity test, the entire frequency range should be scanned in accordance with [Section 3.5.5.3.7](#). In addition to the scanning, the EUT clock frequencies should be tested in accordance with [Table 3-15](#) of [Section 3.5.5.3.7](#).

### 3.5.6.3 Calibration of Test Signal

Configure the equipment as shown in [Figure 3-13](#) to calibrate the injection probe. The calibration fixture consists of a coaxial transmission line with 50 ohm characteristic impedance, coaxial connections on both ends, and space for an injection probe around the center conductor. Place the injection probe around the center conductor of the calibration fixture. Terminate one end of the calibration fixture with a 50 ohm load and terminate the other end with an attenuator connected to a measurement receiver/oscilloscope. Set the signal generator to 10 kHz. Increase the applied signal until the measurement receiver/oscilloscope indicates the specified current level in the center conductor of the calibration fixture. Record the “forward power” to the injection probe. Scan the frequency band from 10 kHz to 30 MHz and record the forward power needed to maintain the required current amplitude.

**NOTE:** If additional information on calibration is necessary refer to MIL-STD-461E,<sup>[17]</sup> CS114; or IEC 61000-4-6.<sup>[28]</sup>

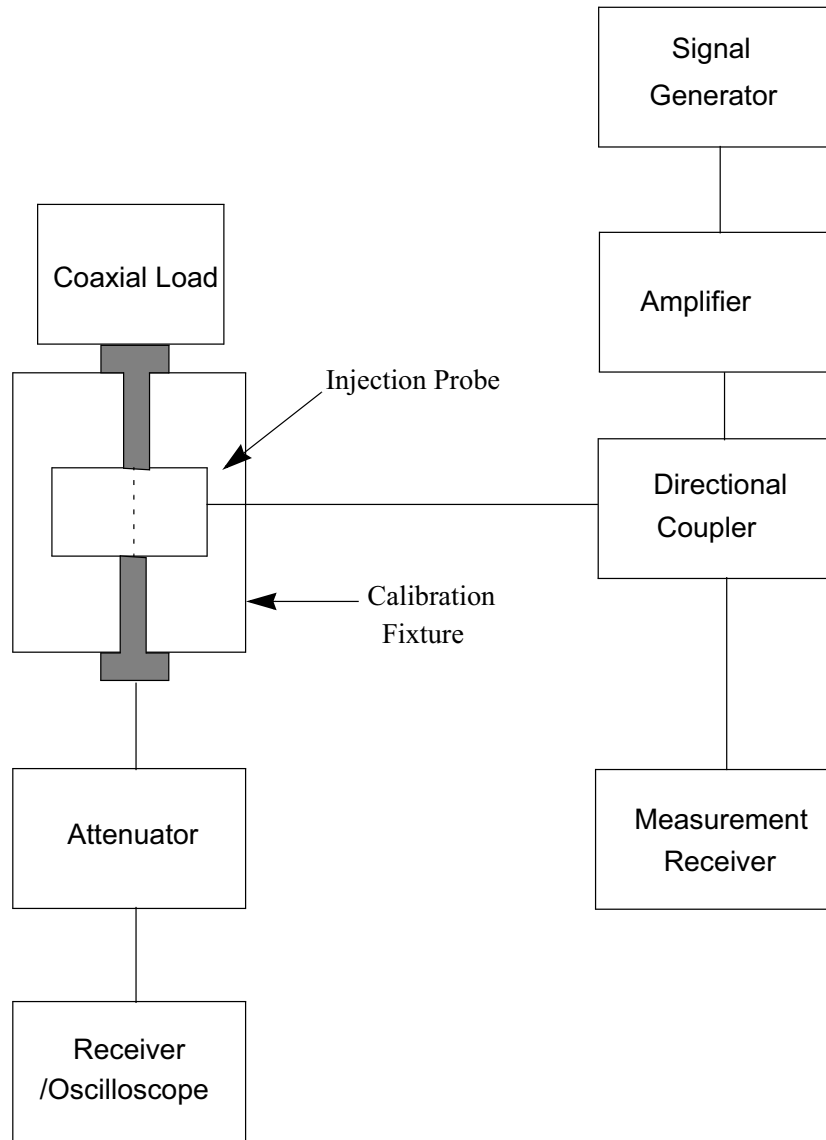
### 3.5.6.4 AC and DC Leads (Common-Mode Injection)

The test setup shown in [Figure 3-14](#) should be used with the measuring instruments described in [Section 3.5.2](#). The receiver connection port of both LISNs must be terminated with 50 ohm terminations. The monitoring current probe should be connected as close as possible (less than 5 cm) to the EUT. The injection current probe should be installed between 10 cm and 30 cm away from the EUT. Note that the monitoring probe is not necessary for the test, but it provides information on the coupled signals. The forward power level determined in [Section 3.5.6.3](#) is applied to the injection current probe while monitoring the induced current. The frequency range is then scanned from 10 kHz to 30 MHz. The applicable conducted immunity tests may be performed as suggested in [Section 3.5.5.3](#).

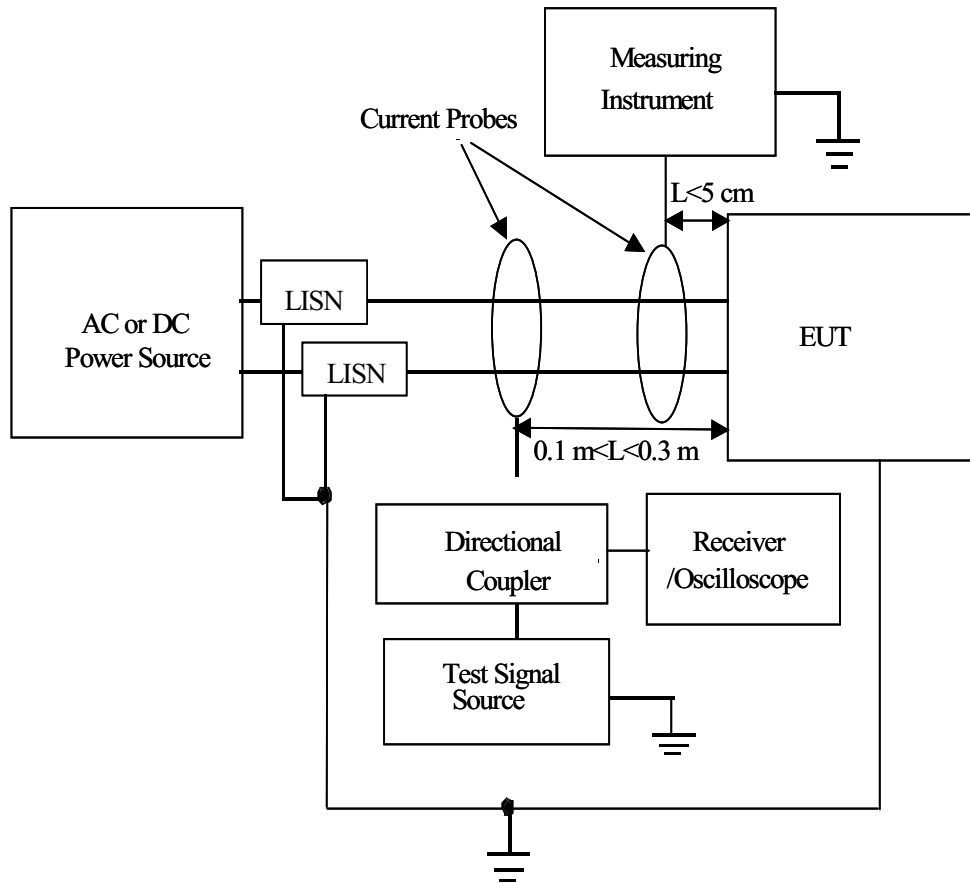
### 3.5.6.5 Telecommunications Ports - Voiceband, Telecommunications and Signal Leads (Common-Mode Injection)

The test setup shown in [Figure 3-15](#) should be used with the measuring instruments described in [Section 3.5.2](#). The voiceband, telecommunications or signal leads of the EUT should be connected to their actual terminations if possible. Alternatively, simulated terminations with the same RF characteristics may be used. The monitoring current probe should be connected as close as possible (less than 5 cm) to the EUT. The injection current probe should be installed between 10 cm and 30 cm away from the EUT. Note that the monitoring probe is not necessary for the test, but it provides information on the coupled signals. The forward power level determined in [Section 3.5.6.3](#) is applied to the injection current probe while monitoring the induced current. The frequency range is then scanned from 10 kHz to 30 MHz. The applicable conducted immunity measurement procedures should be performed as suggested in [Section 3.5.5.3](#).

**Figure 3-13** Injection Probe Calibration Setup

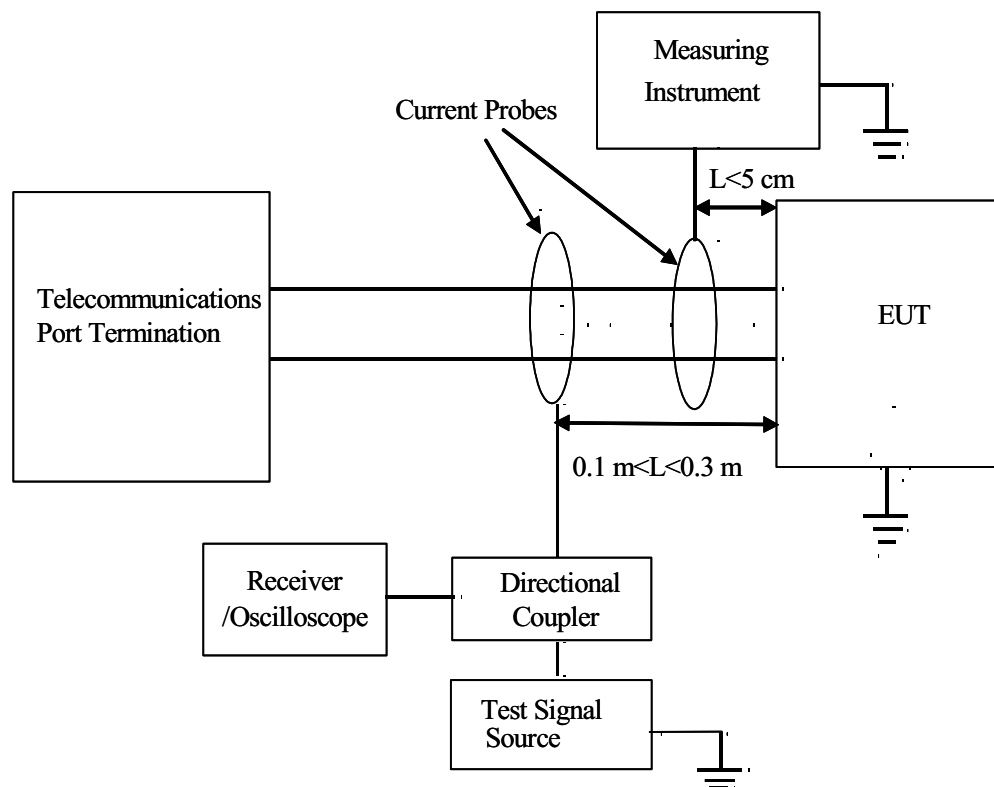


**Figure 3-14** Test Setup for Conducted Immunity Tests on AC and DC Power Ports





**Figure 3-15** Test Setup for Conducted Immunity Tests for Telecommunications Ports (Voiceband, Signal, and Telecommunications Leads)





## 4 Lightning and AC Power Fault

### 4.1 Overview

Metallic conductors, such as cable or wire pairs serving telecommunications equipment, may be exposed to electrical surges resulting from lightning and commercial power system disturbances. Despite the presence of surge protective devices in the telecommunications network that limit the effects of lightning and power surges, a portion of these disturbances is impressed on network equipment.

This section discusses voltages and currents that may occur at terminations of the network because of lightning, and fault conditions on commercial power systems. Generic criteria are provided that are intended to establish that equipment will not be damaged under normal stress, and will fail in a safe manner under less frequently encountered severe stress.

The lightning surge and ac power fault criteria include:

- Lightning surge and ac power fault tests to be applied to telecommunications ports of EUT as described in [Section 4.6](#)
- Protection tests to be applied to telecommunications ports of EUT intended to be located in high-exposure customer premises and OSP facilities as described in [Section 4.7](#)
- Lightning surge and ac power fault tests to be applied to telecommunications ports of EUT protected by agreed primary protection as described in [Section 4.8](#)
- Lightning surge and ac power fault tests to be applied to telecommunications ports of EUT with integrated primary protection as described in [Section 4.9](#)
- Lightning surge and ac power fault tests to be applied to coaxial cable ports of EUT as described in [Section 4.10](#)
- Lightning surge tests to be applied to antenna ports of EUT as described in [Section 4.11](#)
- Lightning surge tests to be applied to ac power ports of EUT as described in [Section 4.12](#)
- Lightning surge tests to be applied to dc power ports of EUT as described in [Section 4.13](#).

Prior to lightning and ac power fault testing, applicable criteria shall be determined by classifying equipment ports as described in [Appendix B](#). Engineering judgement needs to be exercised to ensure that all applicable ports are tested correctly and as intended. Equipment that does not have ports that can be classified as any of the port types identified in [Appendix B](#) are exempt from the tests of [Section 4](#).

### 4.2 Electrical Protection on Paired-Conductor Systems

Where telecommunications paired-conductor OSP is considered exposed to either lightning or commercial power system disturbances, the telecommunications service providers apply primary voltage-limiting protectors to metallic pairs at COs,

remote facilities such as environmental equipment enclosures, and at customers' premises. Where telecommunications OSP is exposed to possible contact with commercial power systems, current-limiting devices (such as 350-mA heat coils) may be applied at the CO in addition to the voltage-limiting protectors for the purpose of limiting current to network equipment in the CO.

#### 4.2.1 Voltage-Limiting Protectors

The voltage-limiting protector with the greatest let-through voltage is a 3-mil-gap carbon block. This device has an upper 3-sigma limiting voltage of 1000 V peak under surge conditions, and 600 Vrms (800 V peak) at 60 Hz. Equipment protected by carbon blocks may be subjected to voltages up to these levels as specified in [Section 4.6](#).

Specific equipment may be protected with lower voltage-limiting protectors than 3-mil carbon blocks. Such surge protection technologies include gas tubes, solid state or hybrids. [Section 4.8](#) specifies criteria for equipment protected by agreed primary protection as defined in [Appendix D](#). In addition, [Section 4.9](#) specifies criteria for equipment with integrated primary protection.

#### 4.2.2 Current-Limiting Protectors

Current-limiting protectors are commonly applied to telecommunications pairs at the CO to limit current to network equipment in the event of commercial power system disturbances. For the most part, these current-limiting protectors have a continuous carry-current rating of 350 milliamperes and are applied on the equipment side of the voltage-limiting protector. Current-limiting protectors are not commonly applied to Electronic Equipment Enclosures (EEEs) or customer premises. Current-limiting protectors may be applied at these locations on a case-by-case basis if required. Tests to determine if current-limiting protectors are required are contained in [Section 4.6.11](#).

#### 4.2.3 Fuse Links

Fuse links are incorporated in the OSP when there is exposure to possible contact with power lines. The fuse link may consist of a section of 24- or 26-American Wire Gauge (AWG) copper telecommunications cable, or where wire plant is used, a length of 20 AWG "block wire." The fuse link coordinates with the current-carrying capability of the primary voltage-limiting protector placed by the telecommunications service provider and is not intended to provide a current-limiting function for connected network equipment.

## 4.3 Lightning on Paired-Conductor Cables

Additional information on lightning surges at the customer network interface, lightning surge measurements performed on telecommunications lines, and carbon-block protector characteristics under surge conditions may be found in GR-1-CORE, *Lightning, Radio Frequency, and 60-Hz Disturbances at the Regional Bell Operating Company Network Interface*.<sup>[29]</sup>

### 4.3.1 Longitudinal Surges

A longitudinal (or common-mode) voltage is defined as 1/2 the sum of the potential differences between the T conductor and earth ground, and the R conductor and earth ground. Relatively low longitudinal voltages may be produced by lightning transients propagated for some distance over the telecommunications T and R conductors. Both conductors may be raised in potential above earth ground to slightly less than the lower of the two voltage-limiting protector breakdown voltages. If both voltage-limiting protectors have breakdown voltages at the 3-mil carbon-block upper 3-sigma limit, a longitudinal voltage of 1000 V may be obtained. Tests 1 and 2 together, test 3, and test 5 (shown in Table 4-2) are intended to simulate lightning transients occurring on T and R conductors equipped with 3-mil carbon-block protective devices.

During nearby lightning strikes, substantial currents approximating the lightning waveform may be conductively coupled to the grounding conductors associated with the telecommunications protector and power ground. The developed longitudinal voltage is controlled by the physical and electrical characteristics of the grounding conductors rather than limited by the protector breakdown voltage. Test 4 shown in Table 4-2, and the test shown in Table 4-4, are intended to simulate lightning transients that may occur in grounding conductors.

### 4.3.2 Metallic Surges

A metallic (or transverse or differential-mode) voltage is defined as a difference of potential between the T and R terminals of a telecommunications pair. Currents caused by lightning, in the absence of protector operation and with balanced terminal equipment and telecommunications loop, cause T and R conductors to attain the same potential and hence do not produce metallic transients. If simultaneous protector device operation occurs, again no metallic transients are produced. Longitudinal excitations of the telecommunications loop may, however, be partially converted to metallic potentials through imperfect balance of any component of the telecommunications circuit.

Protector devices on a pair can, through asymmetrical operation, convert longitudinal surges to metallic surges. The maximum metallic voltage generally occurs when one protector of a pair operates and the other does not.

## 4.4 AC Power Fault on Paired-Conductor Cables

Additional information on the effects of power system faults on telecommunications lines, including currents and fault duration, and carbon-block protector characteristics under 60-Hz conditions, is contained in GR-1-CORE. [29]

### 4.4.1 Power Contact to Telecommunications OSP

Power companies and the telecommunications service providers often serve the same customers, frequently employing joint-use facilities such as supporting structures or a common trench for their respective OSP. Under abnormal conditions, the power and telecommunications lines may come into electrical contact. If the contact occurs to a primary power line, faults may be cleared quickly by the power system (5 seconds or less), and primary protectors will limit 60-Hz voltages appearing on the T or R conductors up to the maximum voltage-limiting characteristic of the protector (e.g., to a maximum of approximately 600 V<sub>rms</sub> with respect to ground for carbon blocks). If the contact occurs to a secondary power line, the full secondary voltage with respect to ground (up to 277 V<sub>rms</sub> in some cases) may appear on telecommunications T and R conductors. The voltage may persist indefinitely as the secondary fault may not be cleared by the power system, and the secondary 60-Hz power voltage is below the operating voltage of the primary protector.

### 4.4.2 Fault Induction From Electric Power Lines

Electric power lines and telecommunications lines often occupy parallel routes as a result of the utilization of joint facilities or the sharing of a common right-of-way. The magnetic field produced by currents in a nearby power line, especially under abnormal conditions such as a phase-to-ground fault, may result in large voltages being induced into the telecommunications lines through electromagnetic coupling. Lightning striking the electric power system may produce a fault with equivalent results. The induced voltages appear longitudinally in the T and R conductors and may approach several thousand volts. Lower levels of induction may result from a high-impedance power fault such as a phase conductor falling to the earth. The resulting unbalanced current is within the normal operating range of the power system, power system breakers or fuses do not operate, and the fault may persist for an extended period of time. The maximum voltage appearing at the network equipment is limited by the primary protector (e.g., between 800 V peak [the 60-Hz 3-sigma level] and 1000 V peak [the 3-sigma surge level] for carbon blocks).

## 4.5 Characterization of Test Generators

Test generators used to apply impulses or ac stress shall be characterized in open-circuit and short-circuit conditions as shown in Figure 4-1. Figure 4-1 illustrates the necessary terminal configurations for characterizing three-terminal (two output terminals and one return terminal) lightning and ac power fault test generators, and the data that need to be recorded during the characterization procedure.

Three-terminal generators are required for performing lightning and ac power fault tests in the common mode, as in test configurations A5 and B of Table 4-1 for 2-wire interfaces, and A5 and A6 of Table 4-1 for 4-wire interfaces. Five-terminal generators are required for performing lightning tests in the common mode, as in test configuration B of Table 4-1 for 4-wire interfaces. When a three-terminal generator is being characterized, the generator must meet the voltage, current, and time-duration requirements on each output terminal, unless otherwise specified. Test generators shall meet the requirements of Table 4-2 through Table 4-32 when characterized in the following manner, with reference to Figure 4-1. Five-terminal generators are characterized in a similar method.

- With both output terminals (1 and 2) in the open-circuit condition, voltage  $V_1$  shall be measured at output terminal 1, and voltage  $V_2$  at terminal 2.
- With output terminal 1 in the open-circuit condition and output 2 in the short-circuit condition, measure voltage  $V_1$  on terminal 1 and current  $I_2$  through terminal 2 (see note 1 of Table 4-1 for power fault generators).
- With output terminal 2 in the open-circuit condition and output terminal 1 in the short-circuit condition, measure voltage  $V_2$  on terminal 2 and current  $I_1$  through terminal 1 (see note 1 of Table 4-1 for power fault generators).
- With both output terminals (1 and 2) in the short-circuit condition, measure currents  $I_1$  and  $I_2$  through the terminals.

Two-terminal generators (with just one output terminal and one return terminal) may be used to perform tests in the differential mode as in test conditions A1 and A2 of Table 4-1 for 2-wire interfaces, and test conditions A1 through A4 of Table 4-1 for 4-wire interfaces. The procedure for characterizing a two-terminal generator is the same as that for the three-terminal generator above, except that only two terminal configurations are necessary for characterizing the generator.

A lightning surge generator used to perform first-level lightning test 5 of Table 4-2 shall be characterized in the following manner.

1. With all output terminals in the open-circuit condition, the voltage shall be measured on each terminal.
2. With the first output terminal in the open-circuit condition and the remaining terminals in the short-circuit condition, the voltage on the first output terminal and the current through each of the remaining terminals are to be measured. This procedure is repeated until the open-circuit voltage and short-circuit current characteristics of each terminal are measured.

For lightning-surge generators, it is necessary to measure the rise-time and decay-time values of the voltage and current waveforms as well as their peak amplitudes. The generator characteristics should first be measured in the positive polarity, then repeated in the negative polarity.

In reference to the lightning tests, the rise-time requirements for the test pulses are *maximum* allowable values, and the decay-time requirements for test pulses are *minimum* allowable values. These values apply for both the voltage and current waveforms.

The rise time and decay time of the lightning generator waveforms shall be characterized as described in Appendix A. The combination waveform (1.2/50 voltage waveform and 8/20 current waveform) where it is used should be characterized per IEEE C62.41.2.<sup>[30]</sup> The waveform of the combination waveform is characterized prior to the addition of any external resistors.

The ac power fault generators shall have a maximum internal impedance of 2 ohms. It is necessary to measure the RMS values of voltage and current and ensure that the ac generator can deliver the specified voltage and current for the durations mentioned.

**NOTE:** While this issue of GR-1089-CORE does not specify the phase angle at which the power faults are delivered, it is recommended that manufacturers of secondary current limiters verify the ability of current limiters to interrupt power fault current initiated at various phase angles.

**NOTE:** During the ac power fault tests, a transient may be caused due to the inductance of the ac generator. To avoid excessive transient, the peak voltage applied to the EUT can be measured and be limited to 1000 V.

Where external resistors are specified for limiting the currents in the short-circuit condition, they shall have a maximum tolerance of  $\pm 10\%$ .

Test generator characteristics shall be measured at the point where the generator, including its connecting or test leads, connects to the EUT terminals. The generator characteristics shall meet all requirements when measured through any cabling or lead length that would be present as part of the generator during an actual test.

External high-voltage and current probes, and a storage oscilloscope, shall be used to determine the characteristics of lightning test generators. Test generator meters shall be used only if they are properly calibrated or if their accuracy can be verified.

---

**R4-1 [26]** Test generators that are utilized to perform the lightning and ac power fault tests **shall** be characterized as described in Section 4.5 to ensure conformance to the voltage, current, and time-duration requirements described in Section 4. This characterization must be performed before the generators are placed into service to ensure they are appropriate for the tests specified. In addition, more frequent verification is required to ensure proper operation of the generators. At a minimum, the steps outlined below **shall** be followed to ensure the generators are meeting the required specifications, at the time the generators are utilized:

1. At least once annually, a full characterization or calibration **shall** be conducted for each type of surge and polarity (as appropriate). The calibration service or laboratory **shall** maintain the waveform plots, and characterization measurement data as quality records. Waveforms are only required for lightning surge generators. The waveforms and measurement data may be obtained by the test laboratory, or a calibration service. If a calibration service is utilized, the waveform plots and data are required as part of the calibration data package provided to the laboratory.

**NOTE:** Step 1 is not applicable to generators that are assembled or adjusted (excluding voltage settings), at the time of use.

2. Periodic verification tests are required to ensure the test equipment is operating properly. If the test equipment is utilized on a regular basis throughout the day,



daily verifications are generally sufficient, but are only required if that particular surge is utilized.

For lightning generators, it is generally sufficient to verify peak voltage and peak current. Based on the design structure of this type of test equipment, the voltage on all the outputs will be the same, therefore it is only necessary to verify the peak voltage on one output. However, peak current on all outputs need to be verified to ensure proper operation. The following are two examples of procedures that are considered acceptable to verify the peak current.

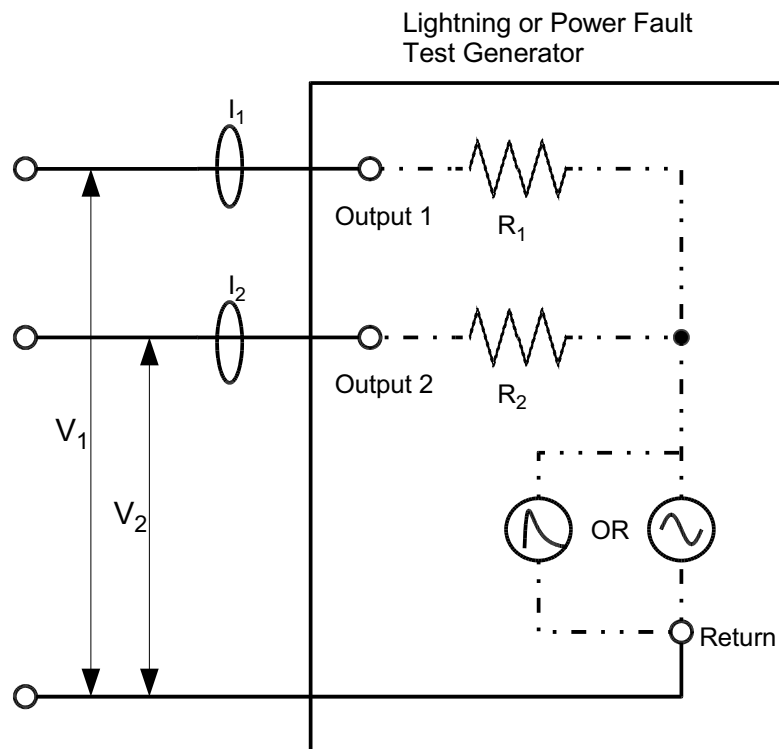
- a. The peak current for each output is measured, or
- b. The currents from all the outputs are measured simultaneously and the resulting peak current measurement is divided by the number of outputs. Output voltages and currents **shall** be taken (measured) using the same connection cable, clip, or plug that is used to connect the generator to the device under test.

The proper operation of AC generators **shall** also be verified to ensure they are within specification utilizing an appropriate procedure. This procedure for verifying current and voltage **shall** be based on the specific design and specific monitoring capabilities of the generator(s).

**NOTE:** For lightning or AC generators that are assembled or adjusted (excluding voltage settings) at time of use, the procedure in Step 2 is not appropriate. Therefore, when these types of generators are assembled/adjusted and utilized, a characterization of [Section 4.5](#) is required to ensure the test specification(s) are met.

3. A declaration of the generator's compliance **shall** be provided in the test report. Oscilloscope plots of the waveforms for each lightning generator utilized, and a description of measurement results **shall** be stored as part of the data sheet package for each product. Power fault generator waveforms are not required.
-

**Figure 4-1** Typical Lightning or AC Power Test Generator



Output 1	Output 2	V <sub>1</sub>	V <sub>2</sub>	I <sub>1</sub>	I <sub>2</sub>
OC	OC			N/A	N/A
OC	SC	Note 1	N/A	N/A	
SC	OC	N/A	Note 1		N/A
SC	SC	N/A	N/A		

SC — Short-Circuit.  
 OC — Open-Circuit.  
 N/A — Not Applicable (No Measurement Made).  
 Note 1: Not applicable for power fault generators.

## 4.6 Criteria for Equipment Interfacing With Telecommunications Ports

In this document, a telecommunications port includes paired-conductor interfaces to other equipment in a telecommunications network (such as T and R leads, sleeve leads, E & M leads). Telecommunications ports shall be tested regardless of what type of traffic they carry or what function they perform. For example, 10BaseT and 100BaseT Ethernet and other similar ports are considered telecommunications ports and shall be tested.

This section also applies to telecommunications ports that provide power to remote telecommunications equipment over OSP telecommunications circuits. Ports that meet certain criteria may not need to be tested as detailed in the applicable intrabuilding sections and [Appendix B](#). Telecommunication ports that are used for setup purposes only (will not be left connected to the EUT) may not require testing.

The intrabuilding tests apply to telecommunications ports of the EUT (Type 2 and 4 Ports of [Appendix B](#)) that are not directly connected to OSP. The tests applied to telecommunications ports of the EUT (Type 1, 3, and 5 Ports of [Appendix B](#)) that are directly connected to the OSP assume that the EUT is designed to be protected by 3-mil carbon blocks.

### 4.6.1 First-Level and Second-Level Criteria

There are first-level and second-level criteria. To comply with the first-level criteria:

- The EUT shall be checked for proper operation prior to the application of the test.
- The EUT, including the host system shall not be damaged and shall continue to operate properly without manual intervention or power cycling after the application of the tests.
- Adjacent ports to the tested port, within the EUT or host system, shall not be damaged and shall continue to operate properly without manual intervention or power cycling after each test sequence.
- The equipment port(s) under test, including any series devices such as POTS splitters that are part of the equipment, shall not have its performance degraded by the application of the test sequence. The proper operation of the equipment shall be verified by testing the performance of port(s) under test at the approximate maximum rated loop length after each test sequence. For multi-rate technologies, a characterization of the performance of the port(s) at a convenient long loop length shall be performed prior to the test sequence. The port(s) is expected to have the same performance level after the test sequence. In general, performance criteria are given in the applicable Technical Generic Requirements, national standards and international standards.

**NOTE:** For series devices that are part of the equipment, such as POTS splitters, their electrical characteristics (i.e., frequency response or component values) may be adversely affected by the surge sequence.

To comply with the second-level criteria when the surges and power faults are applied to the EUT, the EUT may sustain damage, but shall not become a fire or fragmentation hazard (see [Section 4.6.4](#)), and shall not become an electrical safety

hazard (see [Section 7](#)) as a result of the tests of [Section 4](#). For second-level tests, the EUT shall have critical interface components repaired, or the EUT replaced with a fresh sample, before further testing is performed if components or EUT are damaged by the previous test.

#### 4.6.2 Testing Conditions of Telecommunications Ports

During testing of each telecommunications port, other adjacent telecommunications ports associated with the EUT and the host system are to be terminated as in service. Type 1, 3, and 5 ports associated with the EUT and the host system that are not adjacent to the port under test are to be grounded. For surge test 4 specified in [Table 4-2](#), the ports associated with the EUT and the host system that are not adjacent to the port under test can be left floating. For the purpose of the testing, the necessary type 2 and 4 ports are to be terminated as in service. Other type 2 and 4 ports associated with the EUT and the host system that are not necessary for the testing are to be left floating. Other connections to the EUT and the host system (such as power and control leads) are to be terminated as appropriate for the operating mode(s) of the equipment.

Series passive equipment, such as Cross Connects, should be tested in accordance with the requirements of the appropriate Telcordia GR if applicable. Series-type equipment is defined as equipment that provides a through path for the telecommunications T and R conductors, and is not intended to “terminate” the telecommunications circuit. Some examples are filters, splitters, modular plugs and jacks, and power passing repeaters. These tests on series-type equipment shall be applied to one-side port (e.g., outside plant) first with the other-side port (e.g., CO-type facility or customer premises) open-circuited. These tests are then repeated with the other-side port of the series-type equipment short-circuited. Additionally, series-type equipment containing a ground connection is to be tested with the customer-side T and R terminals grounded. The test is repeated in the reverse direction (i.e., application of the test on the other-side port) except if both ports of the series-type equipment are functionally and symmetrically identical and have similar design and layout rules (traces width).

When lightning and ac power fault tests are being performed, sufficient time may be allowed between the application of surges, or between the application of ac power tests, to permit components to cool to ambient temperature. Lightning and ac power fault tests should be performed in a laboratory arrangement because of considerations of personnel safety and possible equipment damage.

Where metallic ac power fault tests are required to be performed with the Ring (R) conductor grounded first and then repeated with the Tip (T) conductor grounded, it is not necessary to repeat the metallic test with the T conductor grounded if EUT symmetry can be demonstrated, that is, identical components and circuit layout are present at the T and R appearances of the EUT.

When performing second-level AC tests that specify a duration of 15 minutes, it is permissible to terminate the test if the EUT interrupts the current or reduces the applied current to a value less than 50 mA for at least 1 minute.

Each applicable test of Section 4.6 shall be performed in each applicable operating state or mode of the EUT. An applicable operating state is a design-intended functional state in which the equipment may be expected to operate. The long-term operating states of the EUT that may last more than a few seconds in each state shall be stressed with the tests in Section 4.6. Examples of long-term operating states include idle, data transmit, data receive, on-hook, off-hook, talking, span power on, span power off, sealing current on, and sealing current off.

The short-term operating states of the EUT that may last less than a few seconds in each operation should not be stressed with the tests in Section 4.6. Examples of short-term operating states include dialing, ground start, ringing, and MLT testing.

The operating states of the equipment stressed with the tests in Section 4.6 shall be specified in the test report.

An engineering analysis of the EUT may reveal some operating states to be redundant from a testing perspective, since they stress the same circuit components and physical configurations that have already been tested in a previous operating state. Such redundant operating states need not be tested.

**R4-2 [20]** This requirement has been deleted.

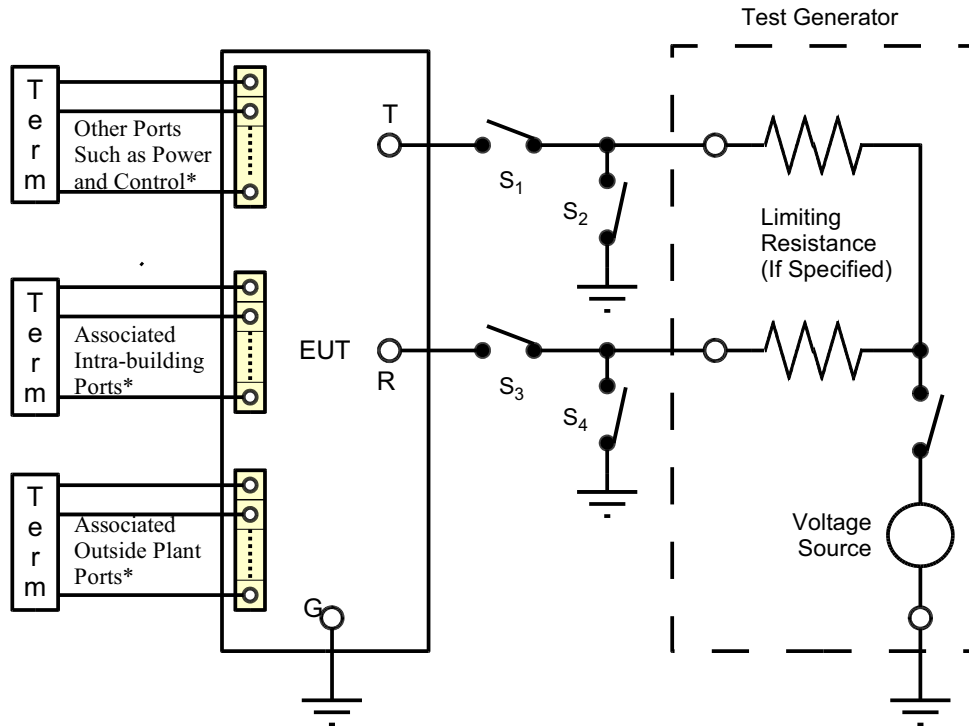
#### 4.6.2.1 Lightning Surge and AC Power Fault Test Connections (Telecommunications Port)

Table 4-1 describes two sets of test connections: one for 2-wire and the other for 4-wire equipment interfaces. These test connections are referenced in the following lightning surge and ac power fault criteria. Guidance in applying the lightning and ac power fault test voltages at T and R appearances is provided in Figure 4-2.

**Table 4-1** Test Connections of Telecommunications Port

Test Conditions	Connections to Test Generator	
	Two-Wire Interfaces	Four-Wire Interfaces
<b>A</b>	1. Tip to Generator, Ring to Ground	1. Tip to Generator Ring, Tip1, Ring1 to Ground
	2. Ring to Generator, Tip to Ground	2. Ring to Generator Tip, Tip1, Ring1 to Ground
	3. Not Applicable	3. Tip1 to Generator Tip, Ring, Ring1 to Ground
	4. Not Applicable	4. Ring1 to Generator Tip, Ring, Tip1 to Ground
	5. Tip and Ring to Generator Simultaneously	5. Tip and Ring to Generator Simultaneously, Tip1 and Ring1 to Ground
	6. Not Applicable	6. Tip1 and Ring1 to Generator Simultaneously, Tip and Ring to Ground
<b>B</b>	Tip and Ring to Generator Simultaneously	Tip, Ring, Tip1, Ring1 to Generator Simultaneously

**Figure 4-2** Application of Lightning and AC Power Fault Test Voltages



\* Ports associated with the unit should be terminated as described in Section 4.6.2.

CONNECTIONS TO TEST GENERATOR

	S1	S2	S3	S4
T TO GENERATOR, R TO GROUND (Condition A1 of Table 4-1)	CLOSED	OPEN	OPEN	CLOSED
R TO GENERATOR, T TO GROUND (Condition A2 of Table 4-1)	OPEN	CLOSED	CLOSED	OPEN
T TO GENERATOR, R TO GENERATOR, SIMULTANEOUSLY (Condition A5 of Table 4-1)	CLOSED	OPEN	CLOSED	OPEN

#### 4.6.2.2 EUT Grounding

The EUT should be grounded in a manner consistent with typical installation of the equipment as declared in [Section 9.3](#) (e.g., as part of an IBN or CBN).

A dedicated low impedance electrical bond must be applied between the EUT earth/frame ground terminals and the ground/return lead(s) of the surge generator.

#### 4.6.2.3 DC Return

The dc return configuration should be as specified by the manufacturer. See [Section 9.8.3](#).

A dedicated electrical bond between EUT grounding terminals and the dc power return should be provided.

#### 4.6.2.4 Test Setup for Equipment Providing or Receiving Remote Power

The test procedure described in this section applies to equipment providing or receiving remote power, with or without data signals (i.e., span power), over OSP copper conductors.

---

**O4-3 [165]** Ten (10) applications of lightning surge test 3 (or tests 1 and 2) of [Table 4-2](#) for each polarity **should** be performed with the EUT connected to function as in service. In addition, an EUT with secondary protection **should** be connected to function as in service when the test 3 (or tests 1 and 2) of [Table 4-2](#) is performed at a reduced voltage open-circuit voltage as described in [Section 4.6.6.1](#). Coupling and decoupling elements **should** be used to isolate auxiliary or load equipment from the surge source supplying a load with the rated current. The remaining 15 applications **should** be performed by applying the surge directly to the port as specified in [Section 4.6.6](#).

Tests at reduced open-circuit voltage as described in [Section 4.6.6.1](#) are permitted to be performed by applying the surge directly to the port as specified in [Section 4.6.6](#) if the reduced voltage is less than the powering voltage applied over the OSP conductors.

**O4-4 [166]** The AC power fault tests of [Table 4-7](#) **should** be performed by applying the ac power fault directly to the port as specified in [Section 4.6.10](#).

---

##### 4.6.2.4.1 Coupling and Decoupling

Coupling elements are required to connect the surge generator to the EUT for **O4-3 [165]**. The coupling element can be a thyristor, an Metal Oxide Varistor (MOV), a Gas Discharge Tube (GDT), a capacitor, or any other element with an operating voltage in excess of the maximum EUT powering voltage. The coupling element should be considered as an integral part of the test generator and should not significantly affect the peak value and pulse width of open-circuit voltage or the

peak value and pulse width of the short-circuit current (to no more than about 5%). It may be necessary to increase the test voltage to compensate for voltage drop in coupling elements. Metallic applications of the surge test may require that coupling elements be forced to operate to ground during the surge. There are a number of ways of connecting coupling elements to ground and a few examples are shown in [Section 4.6.2.4.2](#).

Decoupling elements are used to reduce the surge energy, which would otherwise enter the powering equipment, associated equipment or terminations. The decoupling elements, if necessary, can be an impedance that blocks the surge energy from entering the auxiliary equipment or power source (e.g., twisted pair cable, resistance, inductance or chokes), but still allowing power and signalling to take place to the EUT.

#### 4.6.2.4.2 Examples of Coupling and Decoupling Circuits

This section presents a few examples of coupling and decoupling circuits. These circuits should be usable without additional adjustment to the surge generator.

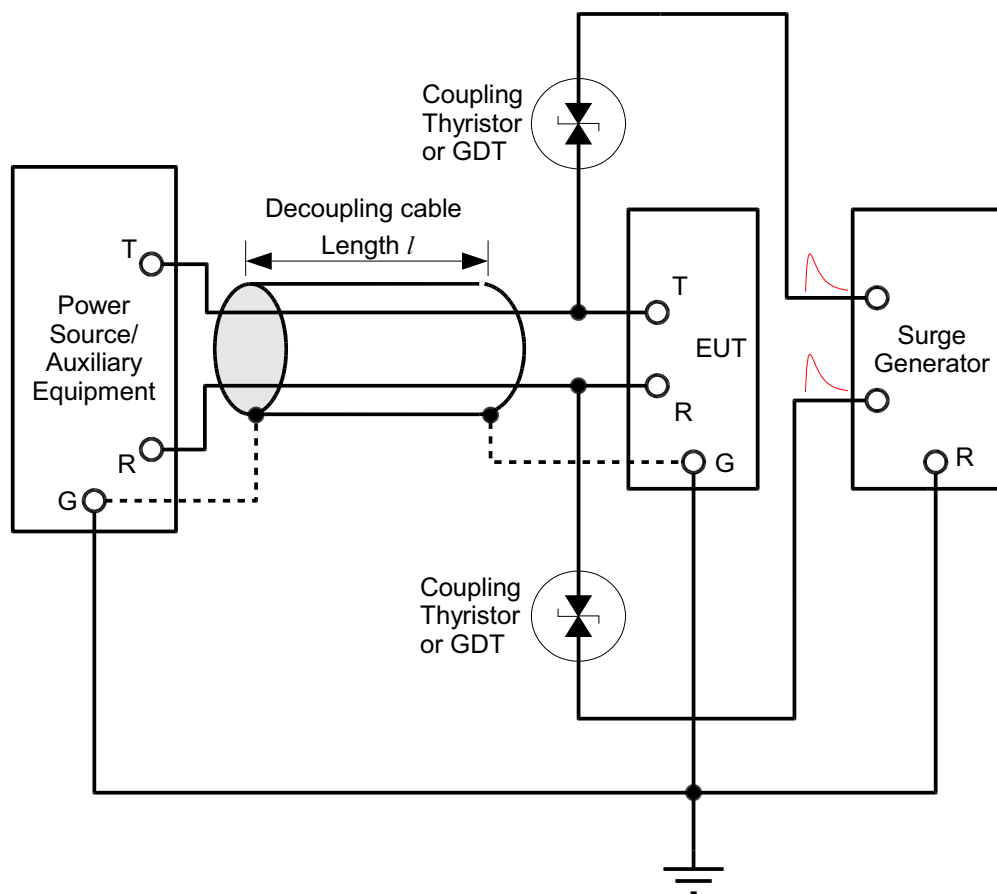
[Figure 4-3](#) shows an example of a test circuit for the longitudinal (common-mode) lightning surge test, and [Figure 4-4](#) shows the test circuit for the metallic (transverse) lightning surge test for a 2-wire interface for equipment supplying or receiving power and data. A 3-element GDT is used in the metallic test to force operation on the conductor to be grounded. The length of cable shall be between 75% and 100% of the maximum rated cable gauge/length combination, but need not be longer than the equivalent of 1000 ft. of 24 AWG cable. [Figure 4-7](#) and [Figure 4-8](#) show similar test circuits for equipment that supply power only.

The coupling thyristors and GDTs in [Figure 4-3](#), [Figure 4-4](#), [Figure 4-7](#), and [Figure 4-8](#) should have the dc break-down voltage that is greater than the maximum power source voltage with respect to ground.

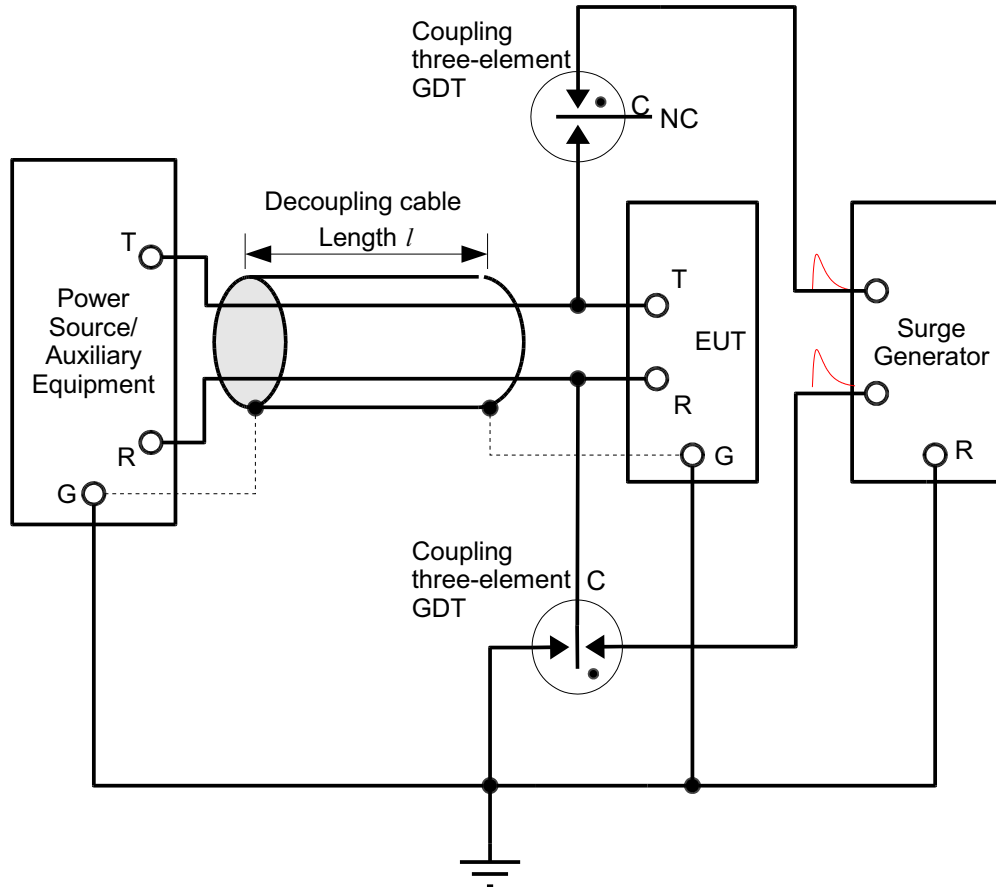
Similar circuits may be used for 4-wire interfaces. [Figure 4-5](#) shows an example for a longitudinal surge test. However, the metallic surge test requires that multiple GDTs be used to ground the remaining wires in the port. Equalizing resistors must be used to operate all of the required GDTs. [Figure 4-6](#) illustrates this circuit.



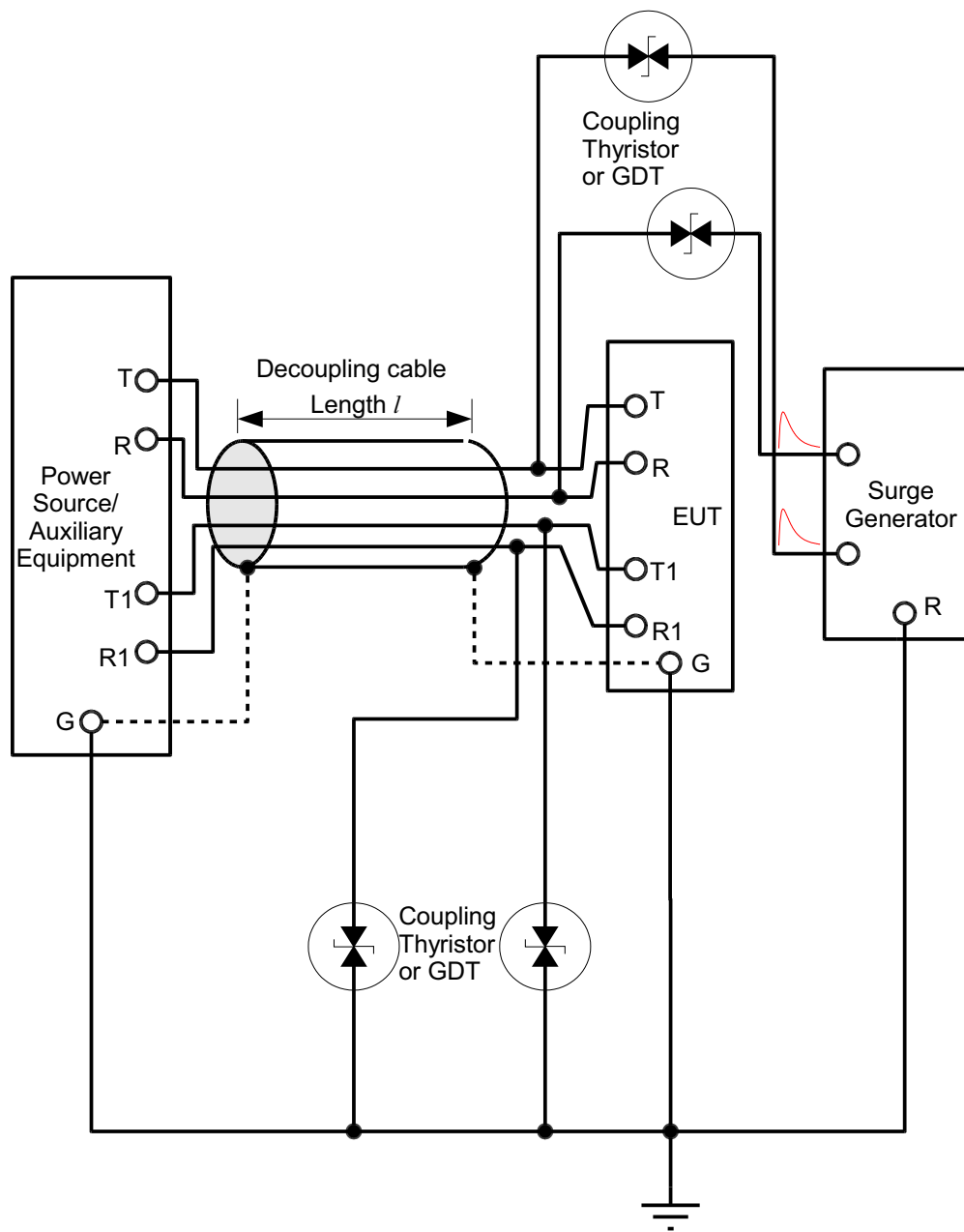
**Figure 4-3** Example Test Circuit for Longitudinal Lightning Surge Test — Two-Wire Interface Configuration A5



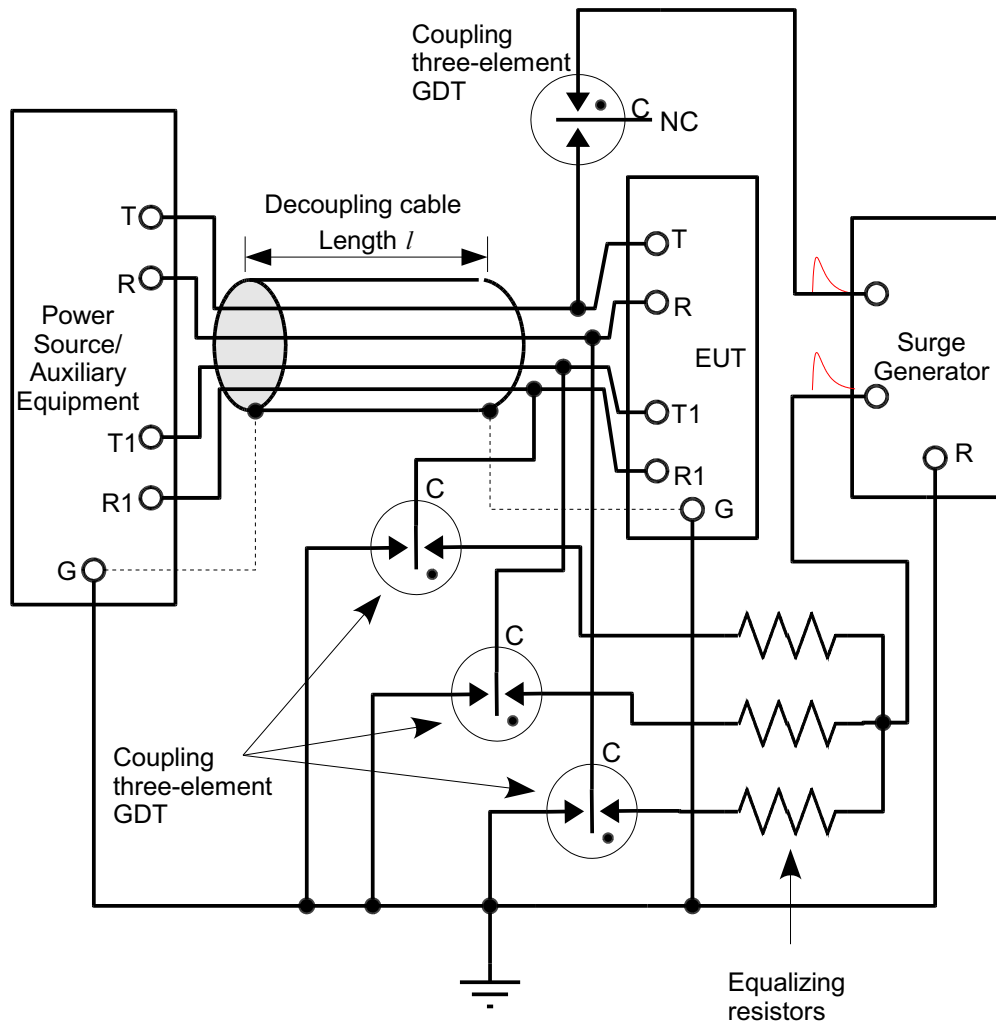
**Figure 4-4** Example Test Circuit for Metallic Lightning Surge Test — Two-Wire Interface Configuration A1 or A2



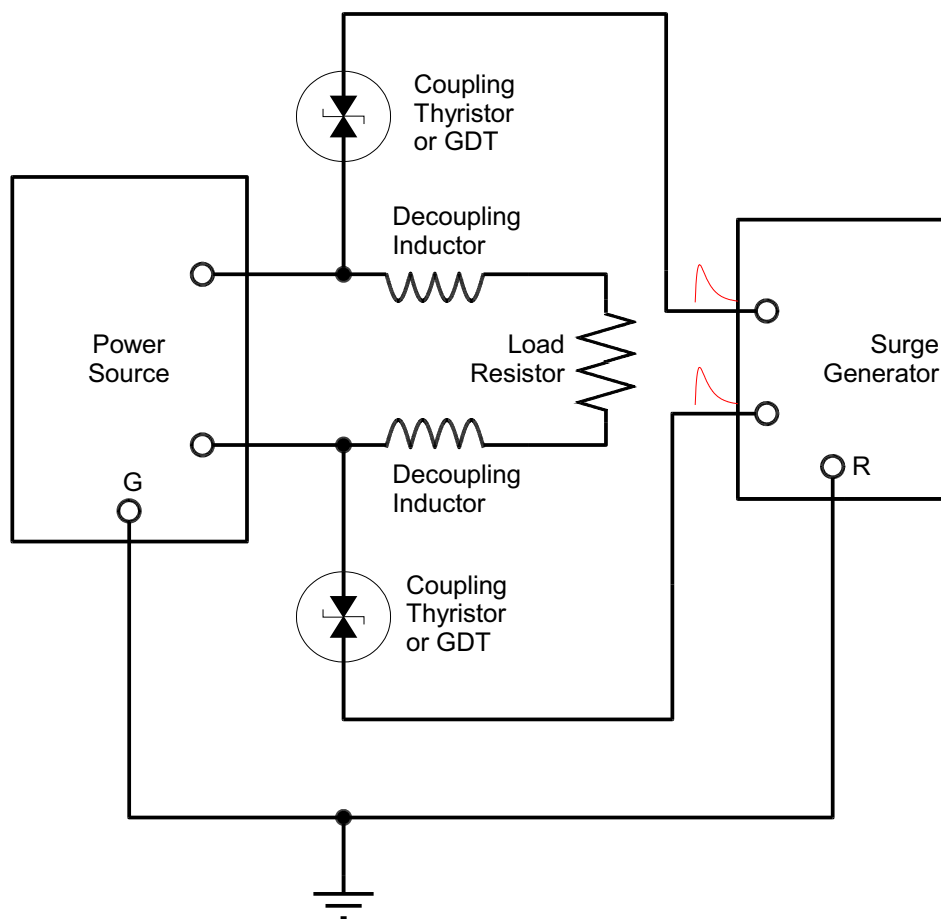
**Figure 4-5** Example Test Circuit for Longitudinal Lightning Surge Test — Four-Wire Interface Configuration A5 or A6



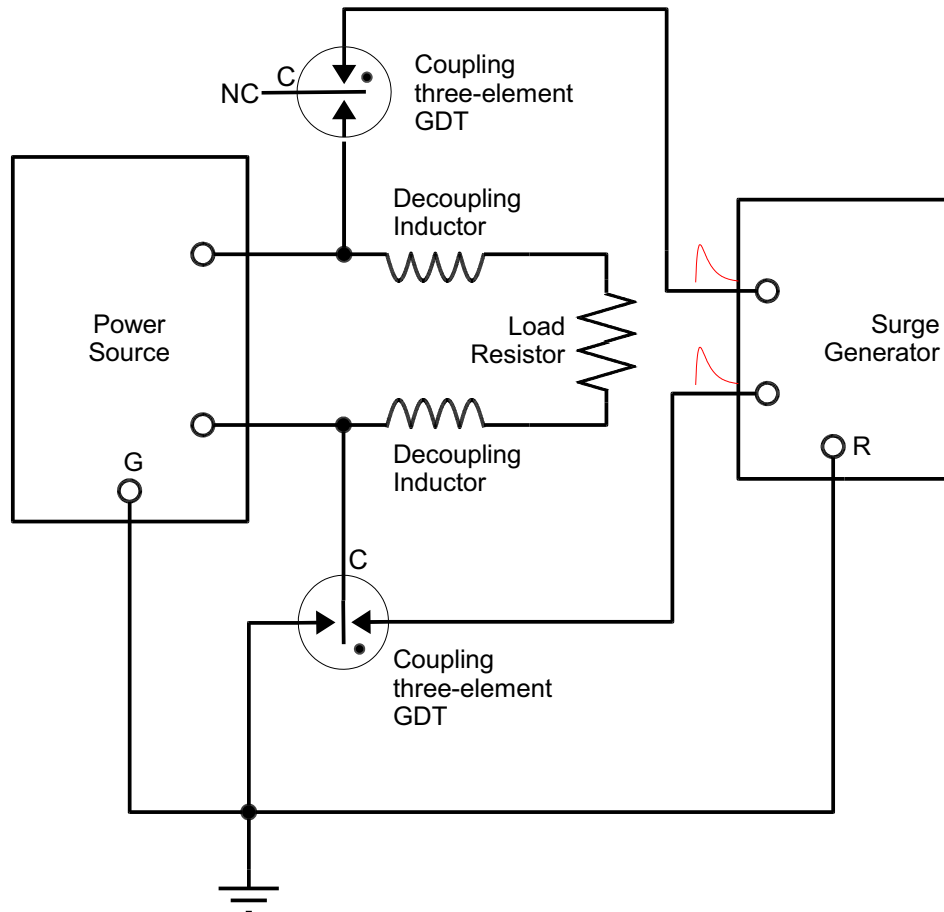
**Figure 4-6** Example Test Circuit for Metallic Lightning Surge Test — Four-Wire Interface Configuration A1, A2, A3, or A4



**Figure 4-7** Example Test Circuit for Longitudinal Lightning Surge Test — Two-Wire Interface Configuration A5



**Figure 4-8** Example Test Circuit for Metallic Lightning Surge Test — Two-Wire Interface Configuration A1 or A2



### 4.6.3 Number of Samples To Be Tested

Three ports of the EUT shall be tested for all the first-level tests described in [Section 4.6](#). For all other tests such as second-level tests and short-circuit tests, a Type Test shall be performed (see [Appendix D](#) for a definition of the Type Test).

For the first-level tests, the following guidelines apply:

- If the EUT has a single telecommunications port, a total of three telecommunications ports shall be tested on three different samples.
- If the EUT has two functionally and schematically identical telecommunications ports, two ports on the same sample and one port on another sample shall be tested.
- If the EUT has three or more functionally and schematically identical telecommunications ports (e.g., line cards), three ports picked at random on the same EUT shall be tested.

Ports that are functionally and schematically identical and have similar design and layout rules (traces widths) are considered equivalent. Ports that are not schematically the same or utilize different design or layout rules that could reasonably affect the outcome of tests are considered different and must each be tested separately.

### 4.6.4 Fire Hazard Indicator for Second-Level Criteria

Bleached, untreated cotton cheesecloth is to be used as the fire hazard indicator when performing second-level tests. The cheesecloth is to run 28 to 30 m/kg (14 to 15 yards per pound), and have a count of “32 × 28 inches” — that is, for any square inch, 32 threads in one direction and 28 threads in the other direction. Two single plies of cheesecloth are to be wrapped tightly around the EUT.

Where the EUT consists of a rack, shelf, or magazine containing circuit packs inserted side-by-side, and the design of the equipment is intended to accommodate a maximum of two rows of circuit packs, the entire rack, shelf, or magazine may be wrapped in cheesecloth, rather than the individual circuit packs. Where the EUT consists of a rack, shelf, or magazine containing circuit packs inserted side-by-side, and the design of the equipment is intended to accommodate more than two rows of circuit packs, individual circuit packs (within the same rack, shelf, or magazine) occupying positions horizontally on either side, as well as circuit packs immediately below and above the circuit pack under test, are to be wrapped in cheesecloth, effectively enclosing the volume occupied by the circuit pack under test. Where a circuit pack is to be tested as a stand-alone assembly or subassembly, the cheesecloth may enclose the volume normally allocated to the circuit pack under test.

Compliance with second-level criteria is indicated by lack of ignition or charring sufficient to destroy the structural integrity of the cheesecloth. Also, ejection of molten material or the forceful ejection of fragments outside the enclosure, or where such a reaction would destroy the structural integrity of the cheesecloth indicator, shall not occur.

#### 4.6.5 Short-Circuit Tests (Telecommunications Type 1, 3, and 5 Ports)

Short-circuit tests are intended to establish that equipment will not be damaged, require manual intervention, or become a fire, fragmentation, or electrical safety hazard as a result of a short circuit on T and R appearances. With the EUT powered and operating as in service, the following short-circuit conditions (no greater than 1 ohm) are to be applied for 30 minutes in each applicable operating state as follows:

- Tip to ring
- Tip to ground with ring open-circuited
- Ring to ground with tip open-circuited
- Tip and ring to ground, simultaneously.

For an EUT having more than one T and R appearance, the short circuit (such as tip-to-ring or tip-to-ground) is to be applied to all T and R appearances, simultaneously. Where the EUT contains many T and R appearances, the short circuit need be applied simultaneously only to the minimum number of T and R appearances that share a common system resource, such as a power distribution fuse or circuit breaker. EUT that passes through power such as sealing current or span power shall be connected to the appropriate power sources when it is tested.

---

**R4-5 [25]** The EUT **shall not** be damaged, **shall not** require manual intervention (such as to reset circuit breakers or replace fuses) to restore service, and **shall not** become a fire, fragmentation, or electrical safety hazard as a result of the application of a short-circuit (no greater than 1 ohm) to T and R appearances for 30 minutes. Cheesecloth is to be applied as described in [Section 4.6.4](#) as the fire hazard indicator.

---

**NOTE:** Dry telecommunications ports such as those not generating or utilizing sealing current or span power **shall not** require testing to the short-circuit tests in [Section 4.6.5](#). Also these tests are not necessary for ports that only terminate sealing current or span power. Examples include span powered ports on remote devices, NIDs, terminal adapters, telephones, modems, etc.

#### 4.6.6 First-Level Lightning Surge Tests (Telecommunications Type 1, 3, and 5 Ports)

##### A. General Test Procedure

System-level testing is intended to establish the lightning surge immunity of the equipment port under test, as well as the entire system. These tests shall be performed on EUT placed in an operating system with the system performing its design-intended functions. If the EUT is operating at a subassembly level, it is placed in an operating system with the system performing its design-intended functions. [Section 4.6.2](#) describes the testing conditions of the telecommunications ports. Proper operation of the system is verified by monitoring an adjacent telecommunications port(s) after the surge sequence (if there are adjacent ports). The port under test is checked for proper operation prior to and after the surge sequence. Manual intervention or power cycling is not permitted before verifying proper operation of the system and the EUT.



For example, if a line card for use in a CO switch is being tested, the line card to be tested is plugged into the switch surrounded by other line cards, and the switch is processing calls. The line card port under test does not need to be handling calls, but the application of surges shall not disrupt operation of other parts of the switch. Proper operation of the switch is verified by monitoring a line card adjacent to the tested line card after each surge sequence. The line card port under test is checked for proper operation prior to and after the surge sequence. Manual intervention (e.g., removal of the tested line card from the CO switch) or power-cycling is not permitted before verification. Other types of systems shall be tested using similar procedures as appropriate.

The test surges should be applied at the terminals of the port under test. For example, if a line card is being tested, the surges are applied directly to the line card or at the backplane connections of the equipment shelf that contains the line card. The ground return connection for the surge test generator should be as close to the EUT as possible, preferably to the equipment framework that contains the EUT. Equipment wiring that is an integral part of the EUT, or that is specified in the equipment installation instructions and documentation, may be in place between the EUT and the surge generator during surge testing. If such wiring is not an integral part of the EUT, or is not specified in the installation instructions or equipment documentation, use of the additional wiring during surge testing may result in application restrictions for the equipment.

The test generators shall be characterized as described in [Section 4.5](#). The resistors of the test generator shown in [Figure 4-2](#) are to be selected to permit the minimum peak current indicated in [Table 4-2](#) to flow on each conductor under short-circuit conditions. When longitudinal tests are performed, the test generator is to have a dual (three-terminal generator) or quad (five-terminal generator) output (24 outputs plus return in the case of surge test 5), or current-dividing resistors as shown in [Figure 4-2](#). The test generator shown in [Figure 4-2](#) is to be set to the minimum peak voltage indicated in [Table 4-2](#) under open-circuit conditions.

#### B. Procedure for Surge Test 5

Surge test 5 in [Table 4-2](#) is intended for:

- Host systems that contain multiple cards in the same shelf (e.g., a CO switch or DSLAM with multiple line cards). The test applies to ports on the cards that are two-wire or multi-wire (e.g., 4-wire and 8-wire) interfaces.
- Network equipment that contains port(s) that are two-wire or multi-wire (e.g., 4-wire and 8-wire) interfaces.

Surge test 5 is to be performed as follows:

- If the host system or network equipment contains ports that interface with 24 or more conductors (e.g., 12 ports with a single pair interface), surge test 5 shall be performed on 24 conductors simultaneously.
- If the host system or network equipment contains port(s) that interface with less than 24 conductors (e.g., one port with a 4-wire interface), surge test 5 shall be performed on all conductors simultaneously.

The test is first performed with the ports selected so they are distributed across the available ports of the entire host system. The test is repeated with the surge applied to ports (up to 24 conductors) selected from those serving a subset of the equipment

that shares a common power distribution fuse. For example, when a CO switch is being tested, the first test would include ports spread across the line cards in the equipment shelf. The second test would be applied to ports spread across the line card. Equipment with a single 2-wire port (e.g., one tip and ring pair) does not need to be tested to surge test 5.

**R4-6 [27]** Upon the application of either surge tests 1, 2, 4, and 5, or surge tests 3, 4, and 5 of Table 4-2, the EUT (e.g., the surged telecommunications ports) including the host system **shall not** be damaged and **shall** continue to operate properly as described in Section 4.6.1. Although surge test 3 contains greater energy, it is provided as a means to expedite testing. Surge test 3 may be applied at the supplier's option in place of surge tests 1 and 2. These lightning surge tests **shall** be performed with the EUT installed in an operating system performing its intended function as described in Section 4.6.2. Series-type network equipment **shall** be tested as described in Section 4.6.2.

Surge test 4 (2.5kV, 2/10 $\mu$ s) **shall not** apply to EUT that is intended solely for installation in dedicated enclosures with the following properties:

- The primary protectors are mounted on the side or within the enclosure.
- The length of the communication conductors between the primary protectors and equipment they protect is less than 1 meter (3.3 feet).
- If a metallic enclosure is used, all terminals of the equipment in the enclosure that require grounding, including the ground terminals of the primary protectors, are bonded to the enclosure using the shortest bonding conductors practicable.
- If a non-metallic or partially-metallic enclosure is used, all terminals of the equipment in the enclosure that require grounding, including the ground terminals of the primary protectors and the metallic members of the enclosure, are bonded to a bonding bus that is less than 1 meter (3.3 feet) in length.
- The length of any bonding conductor within the enclosure does not exceed 1 meter (3.3 feet).
- The longest dimension of the enclosure does not exceed 3 meters (10 feet).

The circuit packs of EUT exempt from surge test 4 **shall** be explicitly labeled to indicate that they must be installed in dedicated enclosures meeting the above specifications. Labeling is not required for circuit packs associated only with specific systems meeting the above criteria.

#### 4.6.6.1 Equipment Ports With Secondary Protection

**R4-7 [167]** If the equipment port under test contains a secondary protector with voltage-limiting device(s), the tests in Table 4-2 **shall** be performed at a reduced open-circuit voltage at the maximum operating peak threshold value of the voltage-limiting device(s). As the result of the application of any of these tests, the EUT (e.g., the surged telecommunications ports) including the host system **shall not** be damaged and shall continue to operate properly as described in Section 4.6.1.

The voltage-limiting device(s) of the secondary protector are to be disabled or removed (if possible) from the port under test to prevent accidental operation. The maximum operating peak threshold value for a voltage-limiting device is the maximum voltage limiting under surge conditions. For example, if the voltage-limiting value ranges from 280 to 350 V peak, the maximum operating peak threshold value is 350 V and the applied open-circuit voltage is to be 350 V.

If the secondary voltage-limiting protection cannot be disabled or removed, the generator specified in test 3 (or test 2) of **Table 4-2** should be used for determining the applied open-circuit voltage. The voltage of the generator should be varied in the range of 100 to 1000 V with incremental steps until the maximum applied voltage that would not operate the secondary voltage-limiting device is determined. The initial steps may be 100 V but it should be reduced as the applied voltage approaches the operation of the secondary protector. In addition, the characteristics of the secondary voltage-limiting devices can be obtained from the manufacturer.

The same generator used during the tests in **Table 4-2** should be utilized for these tests and adjusted to the reduced open-circuit voltage.

**Table 4-2** First-Level Lightning Surge (Telecommunications Port)

Surge	Minimum Peak Voltage (Volts)	Minimum Peak Current per Conductor (Amperes)	Maximum Rise/Minimum Decay Time for Voltage and Current <sup>2</sup> (μs)	Repetitions, Each Polarity	Test Connections per <b>Table 4-1</b> <sup>1</sup>
1	± 600	100	10/1000	25	A
2	± 1000	100	10/360	25	A
3	± 1000	100	10/1000	25	A
(3 may be performed in place of 1 and 2)					
4	± 2500	500	2/10	10	B
5	± 1000	25	10/360	5	Note 3 (up to 24 conductors)

*Notes to **Table 4-2**:*

1. Primary protectors removed for all tests.
2. Double-exponential waveshape as defined in Appendix A. Maximum rise and minimum decay times apply to the voltage waveshape measured into an open circuit and to the current waveshape measured into a short circuit.
3. This test is to be performed on all wires with respect to ground simultaneously.

#### 4.6.7 First-Level Lightning Protection Tests (Telecommunications Type 1, 3, and 5 Ports)

If during Test 3 (or alternatively Test 1) in [Table 4-2](#), the conducted current exceeds 95A or the voltage measured across the EUT port exceeds 95% of voltage-limiting value,  $V_L$ , of the primary protector as specified below, the EUT is considered to comply to this section, without further testing.

Prior to starting testing, the maximum voltage-limiting value,  $V_L$ , of the primary protector needs to be specified. For the EUT that is designed to be protected by 3-mil carbon blocks and tested against [Section 4.6](#), the maximum voltage-limiting value,  $V_L$ , is 1000 V. For EUT tested against [Section 4.8](#), “Criteria for Equipment Interfacing With Agreed Primary Protection.” or [Section 4.9](#), “Criteria for Equipment With Integrated Primary Protection.”, the specified voltage-limiting value ( $V_L$ ) for the primary voltage-limiting protection shall be the “minimum open-circuit voltage” value specified in the applicable Voltage-Limiting Category in Test 1 of [Table 4-13](#) or Test 1 of [Table 4-15](#), respectively.

The surge generator used for these tests shall have a charging open-circuit voltage,  $V_g$ , with a range of at least 400 V to 2000 V and be capable of delivering a short-circuit current of 200 A, 10/1000  $\mu$ s surge at each output terminal with an open-circuit voltage of 2000 V. The surge generator specified in Test 3 of [Table 4-2](#) may also be used, provided that any of the conditions specified below occurs (e.g., 95% of  $V_L$  or 95 A is reached).

The primary protector may optionally be placed in the test circuit shown in [Figure 4-9](#). If the primary protector is placed in the test circuit of [Figure 4-9](#), the protector shall have voltage limiting at a rate of rise of 1 kV/ $\mu$ s within 5% from the specified value  $V_L$ .

If the primary protector is not placed in the test circuit and has a current-limiting protection (or a series element), the lowest resistance value,  $R_c$ , of the current-limiting protection (e.g., 4 ohms for heat coils) should be in series connected to the EUT port terminal (see [Figure 4-9](#)). The measured peak voltage ( $V_p$ ) across the EUT terminal should include the voltage drop of the series resistance ( $R_c$ ) as shown in [Figure 4-9](#). If the primary protector is used, it replaces  $R_c$  in the test circuit shown in [Figure 4-9](#).

Using the test circuits of [Figure 4-9](#), the generator voltage,  $V_o$ , for the repetitive impulse tests must be determined as required in [Table 4-3](#). The determination procedure requires that the charging voltage of the generator,  $V_g$ , be increased in 200 V steps from the specified voltage-limiting value,  $V_L$ , of the primary protector until any of the following conditions occur:

- The terminal voltages to ground (i.e.,  $V_p$ ,  $V_{p1}$ ,  $V_{p2}$ ) in [Figure 4-9](#) reach 95% of the specified voltage-limiting value,  $V_L$ , of the primary protector if the primary protector is not placed in the test circuit of [Figure 4-9](#)
- The voltage-limiting devices of the primary protector operate if the primary protector is placed in the test circuit of [Figure 4-9](#)
- The terminal currents,  $I_p$ , reach 95 A.

As the measured  $V_p$  value approaches 95% of  $V_L$  or the measured  $I_p$  value approaches 95 A, the nominal 200 V step size can be reduced to avoid excessive stress on the EUT. The value of  $V_o$  shall be determined in both impulse polarities, unless the worst-case polarity can either be established by analysis, or analysis establishes that the protection is not phase sensitive. The  $V_o$  value used for longitudinal testing should be the highest  $V_o$  of the two terminals.

Using the value of  $V_o$  as determined above, the EUT must withstand ten (10) repetitions in each polarity as specified in Table 4-3. If a primary protection is used for determining  $V_o$ , it should be removed during the tests specified in Table 4-12. If the testing of Table 4-3 causes EUT damage and EUT does not operate properly as described in Section 4.6.1, then the EUT has failed. See R4-9 [134].

**O4-8 [133]** This objective has been deleted.

**R4-9 [134]** Upon the application of surge tests described in Table 4-3, the EUT (e.g., surge telecommunications ports) including the host system **shall not** be damaged and **shall** continue to operate properly as described in Section 4.6.1.

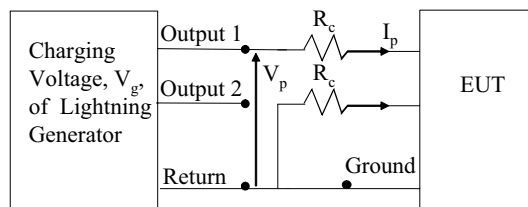
**Table 4-3** Protection Test Criteria (Telecommunications Port)

Surge	Peak Voltage, (Volts)	Maximum Rise/Minimum Decay Time for Voltage and Current <sup>1</sup> (μs)	Repetitions, Each Polarity	Test Connections
1	$V_o$ , value as determined in Section 4.6.7	10/1000	10	A

Notes to Table 4-3:

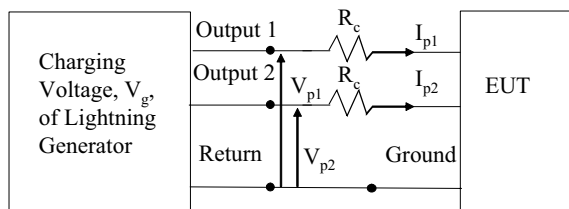
1. Double-exponential waveshape as defined in Appendix A. Maximum rise and minimum decay times apply to the voltage waveshape measured into an open circuit *and* to the current waveshape measured into a short circuit.

**Figure 4-9 Test Arrangement for Determining Protection Coordination**



Note:  $R_c$  is the resistance value of the current-limiting protection or series element that may be used in the primary protector

**A) Metallic**



Note:  $R_c$  is the resistance value of the current-limiting protection or series element that may be used in the primary protector

**B) Longitudinal**

**4.6.8 Second-Level Lightning Surge Tests (Telecommunications Type 1, 3, and 5 Ports)**

Cheesecloth is to be applied as described in Section 4.6.4 as the fire hazard indicator. This second-level test, which may be destructive, may be performed with the equipment operating at a subassembly level equivalent to the standard system configuration.

The resistors of the test generator shown in Figure 4-2 are to be selected to permit the minimum peak current indicated in Table 4-4 to flow on each conductor under short-circuit conditions. The test generator shown in Figure 4-2 is to be set to the minimum peak voltage indicated in Table 4-4 under open-circuit conditions.

**R4-10 [29]** As a result of the application of the second-level surge shown in Table 4-4, the EUT (e.g., the surged telecommunications ports) including the host system **shall not** become a fire, fragmentation, or electrical safety hazard as described in Section 4.6.1.

This surge **shall not** apply to EUT that is intended solely for installation in dedicated enclosures with the following properties:

- The primary protectors are mounted on the side or within the enclosure.

- The length of the communication conductors between the primary protectors and equipment they protect is less than 1 meter (3.3 feet).
- If a metallic enclosure is used, all terminals of the equipment in the enclosure that require grounding, including the ground terminals of the primary protectors are bonded to the enclosure using the shortest bonding conductors practicable.
- If a non-metallic or partially-metallic enclosure is used, all terminals of the equipment in the enclosure that require grounding, including the ground terminals of the primary protectors and the metallic members of the enclosure, are bonded to a bonding bus that is less than 1 meter (3.3 feet) in length.
- The length of any bonding conductor within the enclosure does not exceed 1 meter (3.3 feet).
- The longest dimension of the enclosure does not exceed 3 meters (10 feet).

The circuit packs of EUT that are exempt from this surge **shall** be explicitly labeled to indicate that they must be installed only in dedicated enclosures meeting the above specifications. Labeling is not required for circuit packs associated only with specific systems meeting the above criteria.

#### 4.6.8.1 Equipment Ports With Secondary Protection

The test need not be repeated at the reduced voltage for the second-level conditions shown in [Table 4-4](#) if conformance has been demonstrated by the performance of the first-level tests of [Section 4.6.6](#).

- R4-11 [168]** If the equipment port under test contains a secondary protector with voltage-limiting device(s), the test in [Table 4-4](#) **shall** be performed at a reduced open-circuit voltage at the maximum operating peak threshold value of the voltage-limiting device(s). As the result of the application of the test, the EUT (e.g., the surged telecommunications ports) including the host system **shall not** become a fire, fragmentation, or electrical safety hazard as described in [Section 4.6.1](#).

The voltage-limiting device(s) of the secondary protector are to be disabled or removed (if possible) from the port under test to prevent accidental operation. The maximum operating peak threshold value for a voltage-limiting device is the maximum voltage limiting under surge conditions. For example, if the voltage-limiting value ranges from 280 to 350 V peak, the maximum operating peak threshold value is 350 V and the applied open-circuit voltage is to be 350 V.

If the secondary voltage-limiting protection cannot be disabled or removed, the generator specified in test 1 of [Table 4-4](#) should be used for determining the applied open-circuit voltage. The voltage of the generator should be varied in the range of 100 to 1000 V with incremental steps until the maximum applied voltage that would not operate the secondary voltage-limiting device is determined. The initial steps may be 100 V but it should be reduced as the applied voltage approaches the operation of the secondary protector. In addition, the characteristics of the secondary voltage-limiting devices can be obtained from the manufacturer.



The same generator used during the tests in [Table 4-4](#) should be utilized for this test and adjusted to the reduced open-circuit voltage.

**Table 4-4** Second-Level Lightning Surge (Telecommunications Port)

Surge	Minimum Peak Voltage (Volts)	Minimum Peak Current per Conductor (Amperes)	Maximum Rise/Minimum Decay Time for Voltage and Current <sup>2</sup> (μs)	Repetitions, Each Polarity	Test Connections per <a href="#">Table 4-1</a> <sup>1</sup>
1	± 5000	500	2/10	1	B

Notes to [Table 4-4](#):

1. Primary protectors removed for all tests.
2. Double-exponential waveshape as defined in Appendix A. Maximum rise and minimum decay times apply to the voltage waveshape measured into an open circuit *and* to the current waveshape measured into a short circuit.

#### 4.6.9 First-Level Intra-Building Lightning Surge Tests (Telecommunications Type 2 and 4 Ports)

**NOTE:** GR-1089-CORE has no second-level intra-building lightning surge criteria.

These tests apply only to network equipment ports that will neither interface with the telecommunications OSP nor serve off-premises equipment (Port Type 2 and 4 as classified in [Appendix B](#)). Intra-building tests are not required if any of the following conditions are met:

- Intra-building wiring (cabling) directly connects equipment within the same frame, cabinet or line-up and where equipment is separated by a distance of 6 m or less. (Ports connected to wiring leaving the line-up shall be tested).
- Intra-building wiring (cabling) connects to equipment that is not grounded, does not have any other connection to ground, and has no power ports.
- Intra-building wiring (cabling) is used only for maintenance purposes and is not connected during normal operation.

Requirements of [Section 4.6.9.1](#) apply to ports that connect to unshielded wiring/cables or cables that are shielded at one end only. Requirements of [Section 4.6.9.2](#) apply to ports that connect to shielded cables. See [Section 4.6.9.2](#) for the conditions that must be satisfied to use the shielded cable requirements.

When performing the tests of [Table 4-5](#) or [Table 4-6](#), the EUT is placed in an operating system with the system performing its design-intended functions. Equipment ports that meet the criteria of [Table 4-2](#) and [Table 4-4](#) do not need to be tested to the criteria of [Table 4-5](#) or [Table 4-6](#), and are considered compliant.

The resistors of the test generator shown in [Figure 4-2](#) are to be selected to permit the minimum peak current indicated in [Table 4-5](#) to flow on each conductor under short-circuit conditions. When longitudinal tests are performed, the test generator is to have a dual (three-terminal generator) or quad (five-terminal generator) output,



or current-dividing resistors as shown in Figure 4-2. The test generator shown in Figure 4-2 is to be set to the minimum peak voltage indicated in Table 4-5 under open-circuit conditions. The combination wave of 1.2/50- $\mu$ s open-circuit voltage waveshape and 8/20- $\mu$ s short-circuit current waveshape as described in IEEE C62.41.2<sup>[30]</sup> shall be used for the tests in Table 4-6.

#### 4.6.9.1 Ports Connected to Unshielded Cables

**R4-12 [30]** Upon the application of the first-level surges shown in Table 4-5 or Table 4-6 the EUT (e.g., the surged telecommunications ports) including the host system **shall not** be damaged and **shall** continue to operate properly as described in Section 4.6.1. These lightning surge tests **shall** be performed with the EUT installed in an operating system performing its intended function. The tests in Table 4-5 apply to one- or two-pair ports. The tests in Table 4-6 apply to ports with more than two pairs (four conductors) and **shall** be permitted to be used for one- or two-pair ports instead of the tests in Table 4-5.

Conductors of the port that are floating (not connected to ground or a component in the EUT) **shall** be excluded from determination of the number of port conductors (pairs) and **shall not** be connected to the surge generator during testing.

Surge test 1 in Table 4-5 or Table 4-6 **shall not** be required for Ethernet ports under the following conditions:

- The port does not have secondary voltage-limiting protection to ground.
- The unused pins of the port are not grounded solidly.

**R4-13 [31]** Equipment or a subassembly that meets the criteria of Table 4-5 or Table 4-6, but does not meet, or is not intended to meet, the criteria of Table 4-2 and Table 4-4, **shall** contain the following, or substantially similar, warning in the equipment installation documentation.

**WARNING:** The intra-building port(s) of the equipment or subassembly is suitable for connection to intrabuilding or unexposed wiring or cabling only. The intra-building port(s) of the equipment or subassembly **MUST NOT** be metallically connected to interfaces that connect to the OSP or its wiring. These interfaces are designed for use as intra-building interfaces only (Type 2 or Type 4 ports as described in GR-1089-CORE, Issue 4) and require isolation from the exposed OSP cabling. The addition of Primary Protectors is not sufficient protection in order to connect these interfaces metallically to OSP wiring.

##### 4.6.9.1.1 Equipment Ports With Secondary Protection

**R4-14 [169]** If the equipment port under test contains a secondary protector with voltage-limiting device(s), the tests in Table 4-5 or Table 4-6 **shall** be performed at a reduced open-circuit voltage at the maximum operating peak threshold value of the voltage-limiting device(s). As the result of the application of the test, the EUT (e.g., the

surged telecommunications ports) including the host system **shall not** become a fire, fragmentation, or electrical safety hazard as described in [Section 4.6.1](#).

The voltage-limiting device(s) of the secondary protector are to be disabled or removed (if possible) from the port under test to prevent accidental operation. The maximum operating peak threshold value for a voltage-limiting device is the maximum voltage limiting under surge conditions. For example, if the voltage-limiting value ranges from 280 to 350 V peak, the maximum operating peak threshold value is 350 V and the applied open-circuit voltage is to be 350 V.

If the secondary voltage-limiting protection cannot be disabled or removed, the generator specified in [Table 4-5](#) or [Table 4-6](#) should be used for determining the applied open-circuit voltage. The voltage of the generator should be varied in the range of 100 to 1000 V with incremental steps until the maximum applied voltage that would not operate the secondary voltage-limiting device is determined. The initial steps may be 100 V but it should be reduced as the applied voltage approaches the operation of the secondary protector. In addition, the characteristics of the secondary voltage-limiting devices can be obtained from the manufacturer.

The same generator used during the tests in [Table 4-5](#) or [Table 4-6](#) should be utilized for these tests and adjusted to the reduced open-circuit voltage.

**Table 4-5** First-Level Intra-Building Lightning Surge for One- and Two-Pair Ports (Telecommunications Port)

Surge	Minimum Peak Voltage (Volts)	Minimum Peak Current per Conductor (Amperes)	Maximum Rise/Minimum Decay Time for Voltage and Current <sup>1</sup> (μs)	Repetitions, Each Polarity	Test Connections per <a href="#">Table 4-1</a>
1	± 800	100	2/10	1	A1, A2, A3, A4 <sup>2</sup>
2	± 1500	100	2/10	1	B

Notes to [Table 4-5](#):

1. Double-exponential waveshape as defined in Appendix A. Maximum rise and minimum decay times apply to the voltage waveshape measured into an open circuit *and* to the current waveshape measured into a short circuit.
2. For 2-wire interfaces, only test connections A1 and A2 apply.

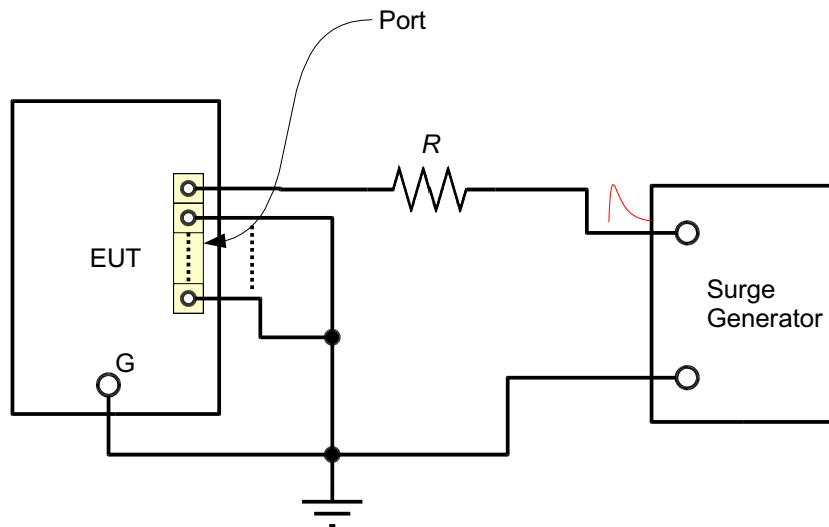
**Table 4-6** First-Level Intra-Building Lightning Surge for Multi-Pair Ports (Telecommunications Port)

Number of Pairs	Surge	Minimum Peak Voltage (Volts) <sup>1</sup>	Values for External Non-Inductive Resistors Shown in Figure 4-10 or Figure 4-11 (Ω)	Surge Generator	Repetitions, Each Polarity	Test Connections per Table 4-1
1 or 2	1	±800	6	The combination wave of 1.2/50-μs open-circuit voltage waveshape and 8/20-μs short-circuit current waveshape with a 2-ohm internal impedance per IEEE C62.41.2 <sup>[30]</sup>	1	A1, A2, A3, A4 <sup>1</sup>
	2	±1500	10		1	B
3 or 4	1	±800	6		1	See Figure 4-10 <sup>2</sup>
	2	±1500	20		1	See Figure 4-11
Greater than 4	1	±800	6		1	See Figure 4-10 <sup>2</sup>
	2	±1500	40		1	See Figure 4-11

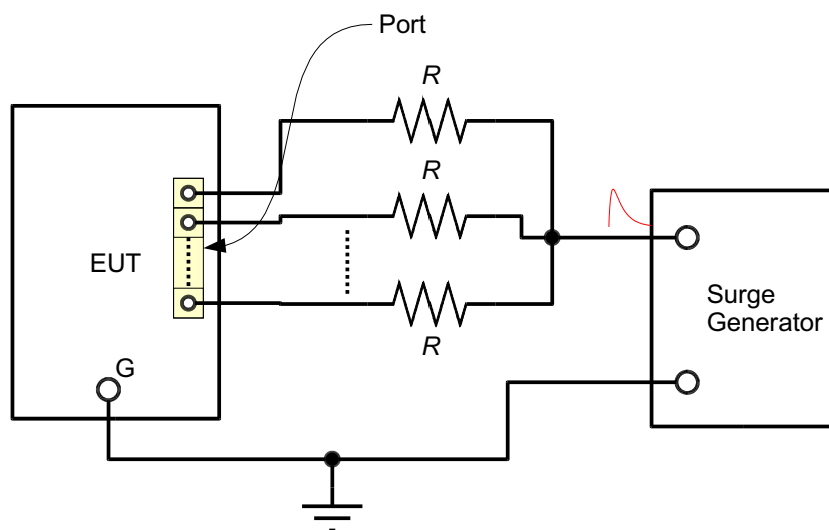
*Notes to Table 4-6:*

1. For 2-wire interfaces, only test connections A1 and A2 apply.
2. For interfaces with more than two pairs, the test is performed by connecting each lead to generator (one at a time) with all other leads grounded, then repeated for each lead.

**Figure 4-10** Test Circuit for Multi-Pair Ports — Metallic Test (Applies to One Conductor at a Time)



**Figure 4-11** Test Circuit for Multi-Pair Ports — Longitudinal Test



#### 4.6.9.2 Ports Connected to Shielded Cables

These tests apply to intra-building equipment ports that provide a connection means to terminate shielded cables. This section applies if all of the following conditions are met:

- The intra-building wiring (cabling) is shielded.
- The manufacturer's documentation states that both ends of the shield must be grounded.
- The equipment intra-building port is designed for and provides a means for termination of the shield.

Otherwise tests of [Section 4.6.9.1](#) apply. Tests in this section do not apply to ports that conform with requirements of [Section 4.6.9.1](#).

---

**O4-15 [170]** This objective will become a requirement effective January 1, 2008. Upon the application of the first-level surges shown in [Figure 4-12](#), the EUT (e.g., the surged telecommunications ports) including the host system **shall not** be damaged and **shall** continue to operate properly as described in [Section 4.6.1](#). These lightning surge tests **shall** be performed with the EUT installed in an operating system performing its intended function. The open-circuit voltage for the test **shall** be 1500 V and the short-circuit current **shall** be limited by an external non-inductive resistor of 2  $\Omega$ . A combination-wave generator **shall** be used as described in [Table 4-6](#) (i.e., the available short-circuit current from the generator will be 375 A limited by the 2  $\Omega$  internal impedance of the generator and the 2  $\Omega$  external resistor).

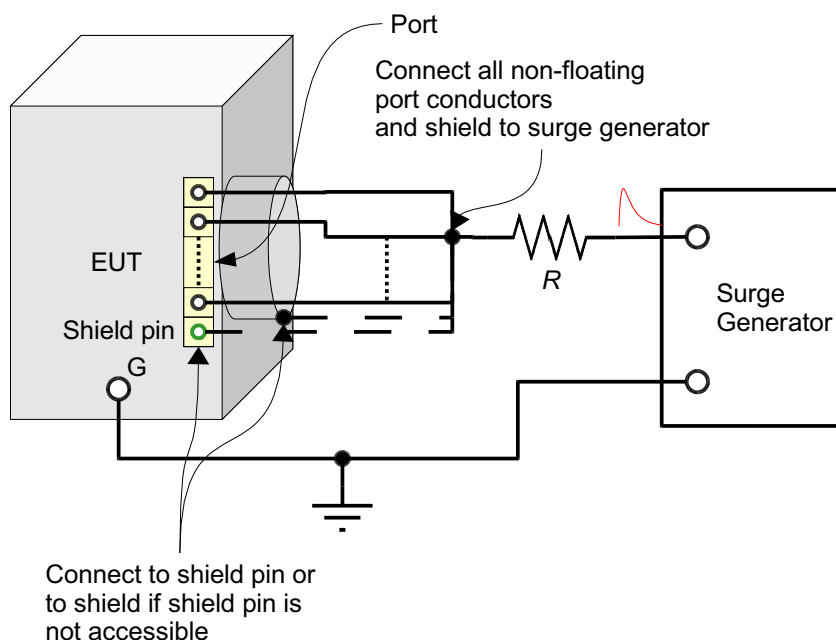
**R4-16 [171]** Equipment or a subassembly that meets the criteria of this section, but does not meet, or is not intended to meet, the criteria of [Table 4-2](#) and [Table 4-4](#), **shall** contain the following, or substantially similar, warning in the equipment installation documentation.

**WARNING:** The intra-building port(s) of the equipment or subassembly is suitable for connection to intrabuilding or unexposed wiring or cabling only. The intra-building port(s) of the equipment or subassembly **MUST NOT** be metallically connected to interfaces that connect to the OSP or its wiring. These interfaces are designed for use as intra-building interfaces only (Type 2 or Type 4 ports as described in GR-1089-CORE, Issue 4) and require isolation from the exposed OSP cabling. The addition of Primary Protectors is not sufficient protection in order to connect these interfaces metallically to OSP wiring.

The equipment documentation **shall** contain a statement indicating that the intra-building port(s) of the equipment or subassembly is suitable for connection only to shielded intra-building cabling grounded at both ends.

---

**Figure 4-12** Test Circuit for Paired-Conductor Ports Providing a Connection Means for the Shielded Cable



#### 4.6.10 First-Level AC Power Fault Tests (Telecommunications Type 1, 3, and 5 Ports)

System-level testing is intended to establish the ac power fault immunity of the ports under test, as well as the entire system. The general test conditions of the EUT are described in Section 4.6.6.

The resistors shown in Figure 4-2 are to be selected to permit the current indicated in each test in Table 4-7 to flow in each conductor under short-circuit conditions. The test generator shown in Figure 4-2 is to be set to the voltage indicated in Table 4-7 under open-circuit conditions.

---

**R4-17 [35]** Upon the application of ac tests 1 through 9 shown in Table 4-7, the EUT (e.g., the surged telecommunications ports) including the host system **shall not** be damaged and **shall** continue to operate properly as described in Section 4.6.1. These ac power fault tests **shall** be performed with the EUT installed in an operating system performing its intended function as described in Section 4.6.2. Series-type network equipment **shall** be tested as described in Section 4.6.2.

---

##### 4.6.10.1 Equipment Ports With Secondary Protection

---

**R4-18 [172]** If the equipment port under test contains a secondary protector with voltage-limiting device(s), tests 1, 2, and 3 in Table 4-7 **shall** be performed at a reduced open-

circuit voltage at the maximum operating peak threshold value of the voltage-limiting device(s). The applied rms voltage **shall** be  $0.707 \times$  the maximum operating peak threshold value of the voltage-limiting device. As the result of the application of any of these tests, the EUT (e.g., the surged telecommunications ports) including the host system **shall not** be damaged and **shall** continue to operate properly as described in [Section 4.6.1](#).

- R4-19 [173]** If the equipment port under test contains a secondary protector with a self-resettable current-limiting device that operated during the current tests 1, 2, and 3 in [Table 4-7](#), a test **shall** be performed at a reduced rms current level at the maximum operating threshold value of the current-limiting device. As the result of the application of any of these tests, the EUT (e.g., the surged telecommunications ports) including the host system **shall not** be damaged and shall continue to operate properly as described in [Section 4.6.1](#).

For **R4-18 [172]**, the voltage-limiting device(s) of the secondary protector are to be disabled or removed (if possible) from the port under test to prevent accidental operation. The maximum operating peak threshold value for a voltage-limiting device is the maximum voltage limiting under 50-Hz or 60-Hz conditions. For example, if the voltage-limiting value ranges from 280 to 350 V peak, the maximum operating peak threshold value is 350 V and the applied open-circuit voltage is to be 248 Vrms. If the secondary voltage-limiting protection can't be disabled or removed, the generator specified in test 3 of [Table 4-7](#) should be used for determining the applied rms voltage ( $V_S$ ). The voltage of the generator should be varied in the range of 100 to 600 V with incremental steps until the maximum applied voltage that would not operate the secondary voltage-limiting device is determined. The initial steps may be 100 V but it should be reduced as the applied voltage approaches the operation of the secondary protector. The same generator used during the tests in [Table 4-7](#) should be utilized for these tests and adjusted to the reduced rms voltage.

For **R4-19 [173]**, the maximum operating threshold value for a current-limiting device is the maximum rms current level that would not be interrupted within the duration specified for each test in [Table 4-7](#). The applied current level shall not exceed the current level specified in [Table 4-7](#). The current-limiting device(s) of the secondary protector may be bypassed on the port under test to prevent accidental operation. For these tests, the voltage of the test generator used during the tests in [Table 4-7](#) should remain constant while the short-circuit current is reduced.

The characteristics of the secondary voltage-limiting and current-limiting devices can be obtained from the manufacturer.

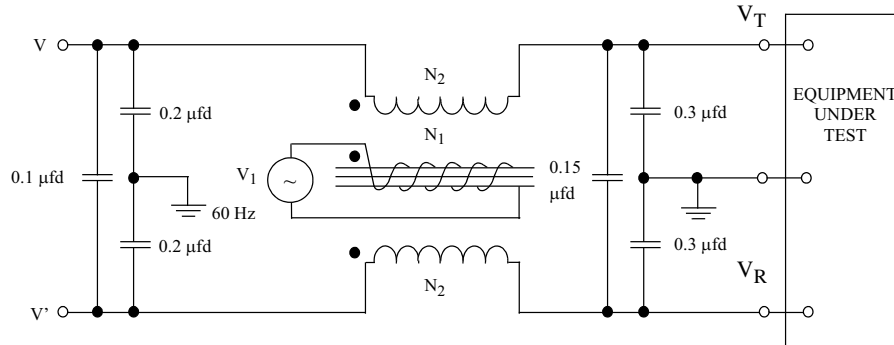
**Table 4-7** First-Level AC Power Fault (Telecommunications Port)

Test	Voltage (Vrms) <sup>1</sup>	Short-Circuit Current per Conductor (Amperes)	Applications	Duration	Primary Protectors	Test Connections per Table 4-1
1	50	0.33	1	15 minutes	Removed	A
2	100	0.17	1	15 minutes	Removed	A
3	200, 400, and 600	1 (at 600 V)	60	1s of each voltage	Removed	A
4	1000	1	60	1s	Operative Protector in Place	B
5	See Figure 4-13	See Figure 4-13	60	5s	Removed	See Figure 4-13
6	600	0.5	1	30s	Removed	A
7	440	2.2	5	2s	Removed	A
8	600	3	5	1.1s	Removed	A
9	1000	5	5	0.4s	Operative Protector in Place	B

*Notes to Table 4-7:*

1. All sources are 50 or 60 Hz sinusoidal.



**Figure 4-13** High-Impedance Inductive Source Test Circuit**Notes:**

1. Equipment to be tested as it would be connected and powered in normal service.
2. The test circuit with EUT disconnected is prepared for testing by adjusting the voltage  $V_1$  until the voltage measured with respect to ground at  $V$ ,  $V'$ ,  $V_T$ , or  $V_R$  equals 600 Vrms. After adjusting  $V_1$ , either the sixty 5-second applications for first-level Test 5 of Table 4-7, or the 15-minute steady-state application for second-level test 5 of Table 4-8 is applied to the EUT.
3. For 4-wire interfaces, two circuits, as depicted in Figure 4-13, should be utilized with the voltage source  $V_1$  applied to all four conductors simultaneously.
4. The capacitors in the test network should have adequate voltage and dissipation ratings.
5. The primary-to-secondary turns ratio ( $N_1:N_2$ ) of the transformer is arbitrary, but should be the same on each secondary (line conductor).
6. Source  $V_1$  should have a minimum volt-ampere rating of 50 VA.
7. Primary protector removed.

#### 4.6.11 Current-Limiting Protector Tests for Equipment To Be Located at Network Facilities (Type 1 Telecommunications Port)

This section applies only to network equipment with Type 1 telecommunications ports. Second-level tests, which may be destructive, may be performed with the EUT operating at a subassembly level equivalent to the standard system configuration. When testing at the subassembly level, the backplane must be capable of handling the currents allowed by the circuit packs so the host does not become a fire hazard.

Current-limiting protectors are to be specified for equipment that permits excessive current to flow under power fault conditions. An external current-limiter indicator as illustrated in Figure 4-14 and test circuits, as illustrated in Figure 4-15 and Figure 4-16, may be used to determine if the time-current characteristic of the EUT falls in the acceptable region shown in Figure 4-14.

- R4-20 [34]** In addition to the EUT itself not becoming a fire or electrical safety hazard, external current-limiting protectors (such as heat coils) **shall** be specified in the equipment documentation for use with equipment that exceeds the allowable time-current criteria shown in [Figure 4-14](#). This **shall** be demonstrated by the test procedure described in [Section 4.6.11.1](#).
- CR4-21 [135]** Equipment, intended to provide digital services at bit rates greater than 1.544 Mbps or operating above 1.1 MHz and requiring the application of external current-limiting protectors, **shall** specify in the equipment documentation that external current-limiting protectors **shall** meet the requirements of Section 7.3, “High-Speed Digital Networks,” of GR-974-CORE.<sup>[31]</sup>
- CO4-22 [136]** Equipment intended to provide digital services at bit rates greater than 1.544 Mbps or operating above 1.1 MHz **should not** require the application of external current-limiting protectors.

#### 4.6.11.1 Test Procedure

The external current-limiter indicator consists of a fuse or device having a time-current characteristic at the upper limit of the acceptable region shown in [Figure 4-14](#). A Type MDQ 1-6/10A or Type MDL 2.0A fuse manufactured by Bussman Manufacturing Company or their equivalent, is acceptable as the external current-limiter indicator. Cheesecloth is to be applied as discussed in [Section 4.6.4](#) as the fire hazard indicator.

**NOTE:** It is also permissible to use non-invasive time-current measurement techniques to determine compliance with the time-current characteristic of [Figure 4-14](#).

The metallic test shown in [Figure 4-15](#) (A) is to be performed first with the R conductor grounded and repeated with the T conductor grounded. It is not necessary to repeat the metallic test if EUT symmetry can be demonstrated, that is, identical components and circuit layout are present at the T and R appearances of the EUT. In addition, the longitudinal test shown in [Figure 4-15](#) (B) is to be performed.

For 4-wire interfaces, in addition to performing the metallic and longitudinal tests shown in [Figure 4-15](#) (A) and (B), an additional pair-to-pair test is to be performed using the test circuit shown in [Figure 4-16](#). The 60-Hz voltage is applied to the T and R pair while the other pair (T<sub>1</sub> and R<sub>1</sub>) is grounded.

The 60-Hz voltage source of [Figure 4-15](#) and [Figure 4-16](#) shall have a maximum internal impedance of 2 ohms. The time-current characteristics of the EUT shall be determined by applying a 60-Hz open-circuit voltage of 600 V<sub>rms</sub> to the (A) test connections shown in Table 4-1, with the EUT connected as shown in [Figure 4-15](#) (A) and (B) and [Figure 4-16](#), as appropriate. The test shall be performed by applying a 60-Hz source with the following short-circuit currents:

- 2.2 and 2.6 A rms for up to 15 minutes. For these tests only, the use of the external current-limiter indicators in [Figure 4-15](#) (A) and (B) and [Figure 4-16](#) are not required. Results from the test at 2.2 A rms performed in accordance with

Table 4-8 of Section 4.6.12 can be used in place of the test at 2.2 A rms in this section.

- 3, 3.75, 5, 7, 10, 12.5, 20, 25, and 30 A rms for up to 15 minutes.

The test begins by the application of the 60-Hz source at a short-circuit value of 2.2 A rms for 15 minutes and continues by repeating the 15-minute application of the 60-Hz source with each subsequent value of the short-circuit current until one of the following occurs:

1. Tests at all specified current values are performed.
2. The equipment interrupts the current or reduces the applied current to a value less than 50 mA for at least 1 minute. In this case, the test continues by proceeding to the application of the 60-Hz source at a short-circuit current of 7 and 30 A rms for 15 minutes.
3. The external current-limiter indicator opens or the acceptable region of the time-current characteristic of Figure 4-14 is exceeded.

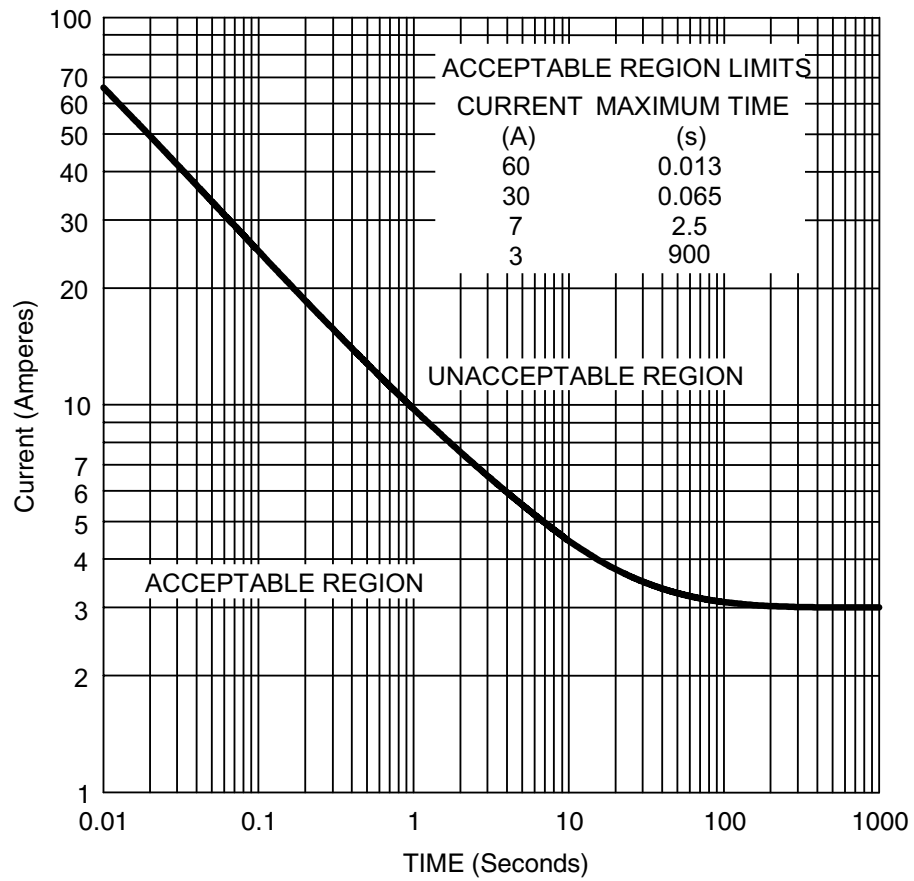
For conditions 1 and 2, the equipment meets the criteria if:

- The external current-limiter indicator does not open or the acceptable region of the time-current characteristic of Figure 4-14 is not exceeded, and
- The equipment does not become a fire, fragmentation, or electrical safety hazard as the result of the application of the tests.

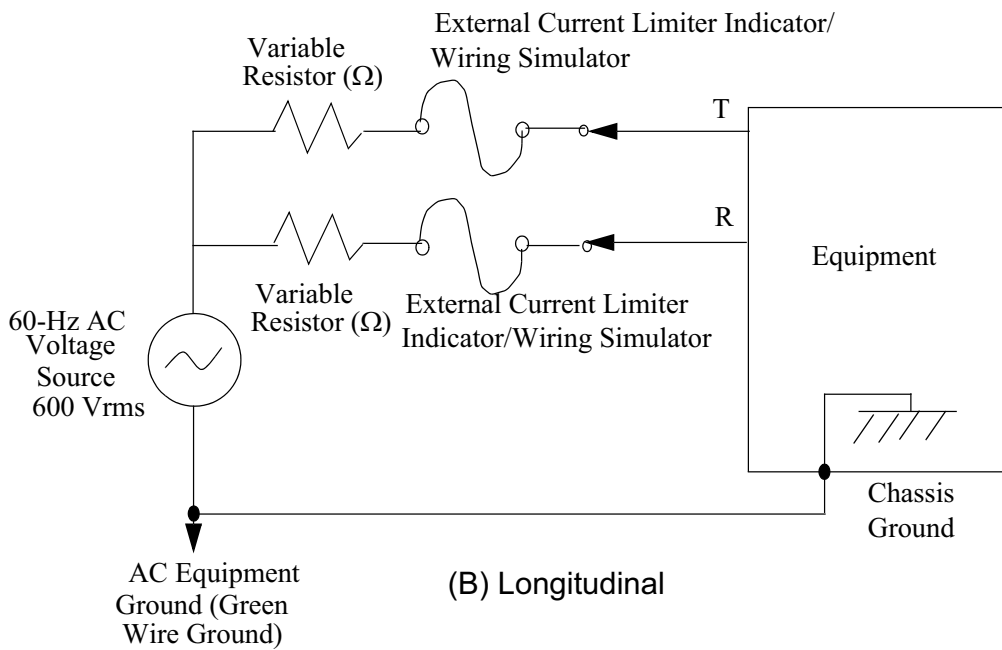
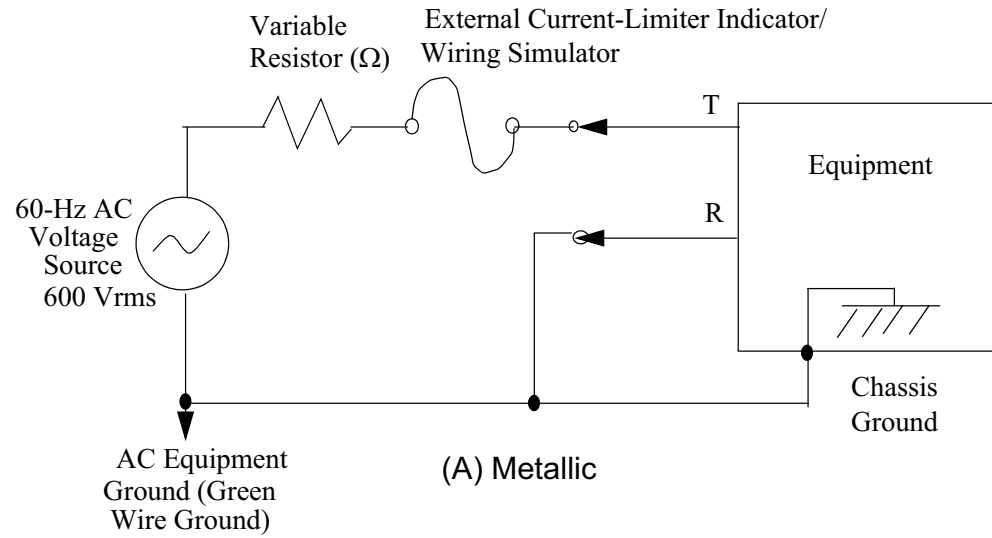
If condition 3 occurs, the EUT has exceeded the acceptable time-current characteristic of Figure 4-14; this indicates that external current-limiting protectors are required.

The tests shall be applied as specified in Section 4.6.2.

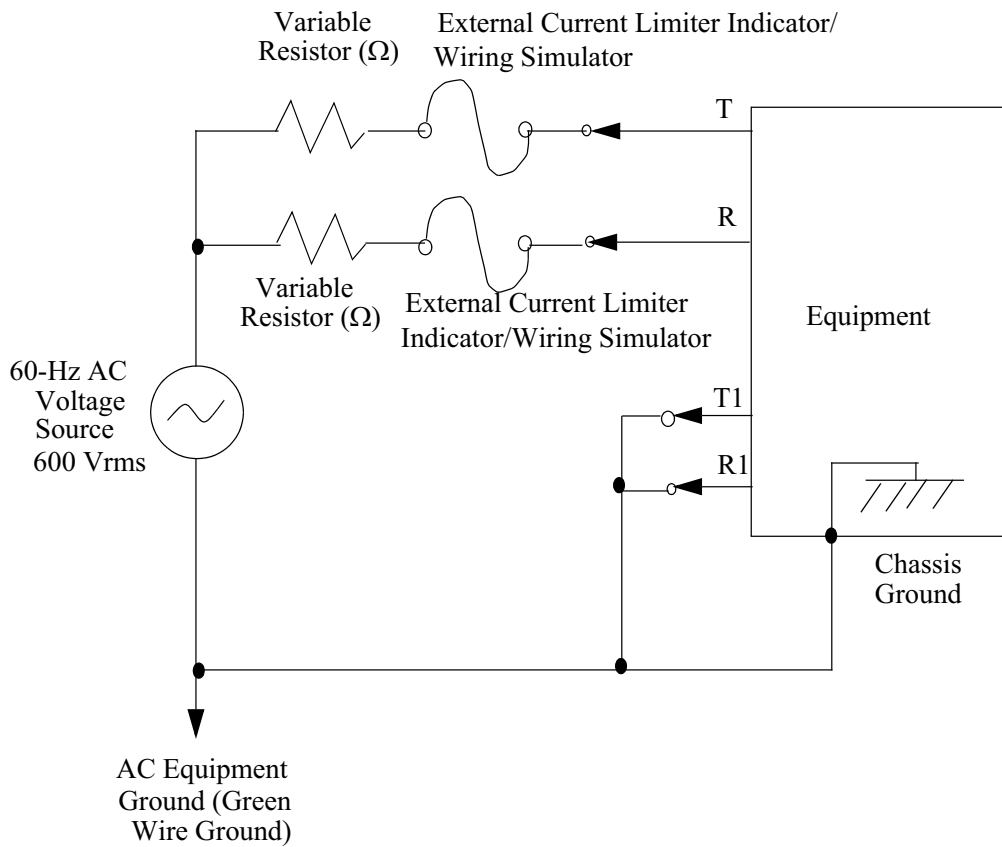
**Figure 4-14** Upper Limit of Time-Current Characteristic of External Current-Limiter Indicator/Wiring Simulator



**Figure 4-15** Second-Level AC Power Fault Test Arrangement Using External Current-Limiter Indicator/Wiring Simulator



**Figure 4-16** Second-Level AC Power Fault Pair-to-Pair Test Arrangement for Four-Wire Interfaces Using External Current-Limiter Indicator/Wiring Simulator



#### 4.6.12 Second-Level AC Power Fault Tests for Equipment To Be Located at Network Facilities (Type 1 Telecommunications Port)

This section applies only to network equipment with Type 1 telecommunications ports. Second-level tests, which may be destructive, may be performed with the EUT operating at a subassembly level equivalent to the standard system configuration. When testing at the subassembly level, the backplane must be capable of handling the currents allowed by the circuit packs so the host does not become a fire hazard. Cheesecloth is to be applied as described in Section 4.6.4 as the fire hazard indicator.

The resistors shown in Figure 4-2 are to be selected to permit the current indicated in each test in Table 4-8 to flow in each conductor under short-circuit conditions. The test generator shown in Figure 4-2 is to be set to the voltage indicated in Table 4-8 under open-circuit conditions.

During these tests, an external current limiter is to be placed between the voltage source and the EUT where current limiters are specified by the manufacturer for use with the equipment (connections similar to those shown in Figure 4-15 and Figure 4-16). The external current-limiter indicator as described in Section 4.6.11.1 can be used instead of the external current limiter during the tests. The use of the external current limiter is not required for tests 4 and 5.

Substantiating data provided by an NRTL as part of a successfully completed listing program is acceptable as an indication of compliance with Test Conditions 1a, 3, and 4 of Table 4-8 and Test Condition 2 of Table 4-9. Examples of acceptable listing standards are UL 1459<sup>[32]</sup> and UL 60950-1,<sup>[33]</sup> Test Conditions 2, 3, 4, and 5 of Annex NAC. It is not acceptable to base conformance on the “construction” method described in the listing programs. The actual tests shall be performed to be considered acceptable.

---

**R4-23 [36]** As a result of the application of second-level ac power fault tests shown in Table 4-8, the EUT (e.g., the surged telecommunications ports) including the host system **shall not** become a fire, fragmentation, or electrical safety hazard as described in Section 4.6.1.

---

**Table 4-8** Second-Level AC Power Fault (Telecommunications Port)

Test	Test for	Voltage <sup>1</sup> (Vrms)	Short-Circuit Current per Conductor (Amperes)	Duration	Test Connections per Table 4-1 <sup>2</sup>
1a	Secondary Contact	120	25	15 minutes	A
1b	Secondary Contact	277	25	15 minutes	A
2	Primary Contact	600	60	5 seconds	A
3	Short-Term Fault Induction	600	7	5 seconds	A
4	Long-Term Fault Induction	600	2.2 <sup>3</sup>	15 minutes	A
5	High- Impedance Induction	See Figure 4-13	See Figure 4-13	15 minutes	See Figure 4-13

*Notes to Table 4-8:*

1. All sources are 50 or 60 Hz sinusoidal.
2. Primary protectors removed for all tests.
3. For series-type network equipment connected to multiple terminating equipment, the maximum short-circuit per conductor current available from the generator is to be increased to 5 amperes. This is intended to simulate multiple terminating equipment ports being connected to a single series-type equipment port. Series-type network equipment ports that are connected to a single terminating equipment port are exempt from this note. The manufacturer shall provide sufficient evidence to indicate that the series-type equipment port will only be connected to a single terminating equipment port.

4.6.12.1 Equipment Ports With Secondary Protection

**R4-24 [174]** If the equipment port under test contains a secondary protector with voltage-limiting device(s), tests 1, 3, and 4 of Table 4-9, or alternatively tests 2, 3, and 4 of Table 4-9 shall be performed at the maximum operating peak threshold value of the voltage-limiting device(s). The applied rms voltage,  $V_s$  in Table 4-9, shall be  $0.707 \times$  the maximum operating peak threshold value of the voltage-limiting device. As the result of the application of any of these tests, the EUT (e.g., the surged telecommunications ports) including the host system shall not become a fire, fragmentation, or electrical safety hazard as described in Section 4.6.1.



**R4-25 [175]** If the equipment port under test contains a current-limiting device, test 5 of **Table 4-9** shall be performed at the maximum operating threshold value of the current-limiting device ( $I_S$  in **Table 4-9**) or 2.2A, whichever is lower. As the result of the application of the test, the EUT (e.g., the surged telecommunications ports) including the host system shall not become a fire, fragmentation, or electrical safety hazard as described in **Section 4.6.1**.

The resistors shown in **Figure 4-2** are to be selected to permit the current indicated in each test in **Table 4-9** to flow in each conductor under short-circuit conditions. For tests 1, 3, and 4 of **Table 4-9**, the generator resistance used during tests 2, 3, and 4 in **Table 4-8** should remain constant while the open-circuit voltage is reduced (i.e., the short-circuit current values are based on approximate values of generator resistances).

For tests 3 and 4 of **Table 4-9**, an external current limiter is to be placed between the voltage source and the EUT where current limiters are specified by the manufacturer for use with the equipment (connections similar to those shown in **Figure 4-15** and **Figure 4-16**). The external current-limiter indicator as described in **Section 4.6.11.1** can be used instead of the external current limiter during the tests.

For **R4-24 [174]**, the voltage-limiting device(s) of the secondary protector are to be disabled or removed (if possible) from the port under test to prevent accidental operation. The maximum operating peak threshold value for a voltage-limiting device is the maximum voltage-limiting value under 50-Hz or 60-Hz conditions. For example, if the voltage-limiting value ranges from 280 to 350 V peak, the maximum operating peak threshold value is 350 V and the applied rms voltage ( $V_S$ ) is to be 248 V<sub>rms</sub>. If the voltage-limiting secondary protection cannot be disabled or removed, the generator specified in test 4 of **Table 4-8** should be used for determining the applied rms voltage ( $V_S$ ). The voltage of the generator should be varied in the range of 100 to 600 V with incremental steps until the maximum applied voltage that would not operate the secondary voltage-limiting device is determined. The initial steps may be 100 V but it should be reduced as the applied voltage approaches the operation of the secondary protector.

Tests 3 and 4 of **Table 4-9** shall not be required if the current monitored during test 1 or 2 of **Table 4-8** does not exceed 50 mA for the first ten (10) seconds. The test report shall provide sufficient information, including the record of the measured current, to justify the exemption.

For **R4-25 [175]**, the maximum operating threshold value for a stand-alone current-limiting device is the maximum rated rms current level that it will carry for 15 minutes (not to exceed 2.2 amperes). The current-limiting device(s) of the secondary protector may be bypassed on the port under test to prevent accidental operation. If the current-limiting device is not bypassed or disabled, and the current-limiting device operates during the test, the test shall be repeated with the current-limiting device(s) of the secondary protector disabled or bypassed on the port under test.

The characteristics of the secondary voltage-limiting and current-limiting devices can be obtained from the manufacturer.

**Table 4-9** Second-Level AC Power Fault for Equipment Ports With Secondary Protection (Telecommunications Port)

Test	Voltage <sup>1</sup> (Vrms)	Short-Circuit Current per Conductor (Amperes)	Duration	Test Connections per Table 4-12
1	$V_s$	$V_s/272^{[3]}$	15 minutes	A
2	$V_s$	2.2	15 minutes	A
(Either Test 1 or 2 may be performed)				
3	$V_s$	$V_s/10^{[3]}$	5 seconds	A
4	$V_s$	$V_s/85^{[3]}$	5 seconds	A
5	600	$I_s$ (maximum of 2.2A)	15 minutes	A

Notes to Table 4-9:

1. All sources are 50 or 60 Hz sinusoidal.
2. Primary protectors removed for all tests.
3. The numeric values represent the approximate generator resistance used during the tests 2, 3, and 4 in Table 4-8. The same generator used during the tests 2, 3, and 4 in Table 4-8 may be utilized for these tests with the rms voltage adjusted to  $V_s$ .

**4.6.13 Second-Level AC Power Fault Tests for Series-Type Equipment To Be Located at Network Facilities (Type 1 Telecommunications Port)**

This section applies to series-type equipment with Type 1 telecommunications ports. The tests shall be applied as specified in Section 4.6.2. Tests are performed using the procedures described in Section 4.6.12.

Second-level tests, which may be destructive, may be performed with the EUT operating at a subassembly level equivalent to the standard system configuration. When testing at the subassembly level, the backplane must be capable of handling the currents allowed by the series-type equipment so the host does not become a fire hazard. Cheesecloth is to be applied as discussed in Section 4.6.4 as the fire hazard indicator.

---

**R4-26 [37]** As a result of the application of the second-level ac power fault tests shown in Table 4-8, series-type network equipment **shall not** become a fire, fragmentation, or electrical safety hazard as described in Section 4.6.1.

---

#### 4.6.14 Fusing Coordination Tests for Equipment To Be Located on Customer Premises and OSP Facilities (Type 3 and 5 Telecommunications Ports)

This section applies to telecommunications ports of network equipment that is to be located at OSP facilities or customer premises and intended to interface with the telecommunications OSP or to serve off-premises equipment (see Type 3 and 5 ports in [Appendix B](#)). At the customer premises, the telecommunications port(s) of this equipment (i.e., Type 3 ports) may utilize premises-type wiring including registered jacks (e.g., RJ 11) and telephone modular cords to interface with the OSP, or they may be connected directly through 26 AWG or coarser cable, including cross-connect blocks (e.g., 66-type blocks). At the OSP facilities, the telecommunications port(s) of this equipment (i.e., Type 5 ports) are connected directly through 26 AWG or coarser cable. The tests in this section are intended to indicate that network equipment would not permit excessive current to flow under power fault conditions and coordinate with premises-type wiring or 26-gauge wire.

Tests are performed using a wiring simulator, which differs depending on the connecting means to the OSP. For equipment utilizing premises-type wiring, the wiring simulator is a fuse or non-invasive current monitoring method as described in [Section 4.6.14.1](#). For equipment directly connected using 26 AWG or coarser cable, the wiring simulator is a 30-cm (1-foot) section of 26 AWG copper wire as described in [Section 4.6.14.1](#).

These tests, which may be destructive, may be performed with the EUT operating at a subassembly level equivalent to the standard system configuration. When testing at the subassembly level, the backplane must be capable of handling the currents allowed by the circuit packs so the host does not become a fire hazard.

- 
- R4-27 [39]** In addition to the EUT itself not becoming a fire or electrical safety hazard, any EUT that is to be located on customer premises **shall**, under ac power fault conditions, limit current to values that can be safely carried by customer-premises wiring, plugs, jacks, cross-connects, etc. This **shall** be demonstrated by the application of the wiring simulator as described in the test procedure of [Section 4.6.14.1](#). The wiring simulator **shall not** interrupt the current during the tests, or the acceptable time-current characteristic of [Figure 4-14](#) **shall not** be exceeded as described in [Section 4.6.14.1](#). When the wiring simulator is a 26-gauge wire, it **shall not** become sufficiently hot to damage the cheesecloth.
- 

##### 4.6.14.1 Test Procedure

For premises-type wiring, the wiring simulator consists of a fuse or device having a time-current characteristic at the upper limit of the acceptable region shown in [Figure 4-14](#). A Type MDQ 1-6/10A fuse or Type MDL 2.0A fuse, manufactured by Bussman Manufacturing Company or their equivalent, is acceptable.

**NOTE:** It is also permissible to use non-invasive time-current measurement techniques to determine compliance with the time-current characteristic of [Figure 4-14](#).

Where equipment is intended to be connected to the network using 26 AWG or coarser cable, and the manufacturer specifies the complete installation of the equipment from the network interface, a 1-foot section of No. 26 AWG copper wire may be used as the wiring simulator. The wiring simulator is to be connected to a representative installation, including wiring, connectors, cross-connect punchings, etc. The fire hazard for cable-connected equipment is indicated by the application of cheesecloth as described in [Section 4.6.4](#) not only to the EUT, but also to the representative installation, including the wiring simulator.

The metallic test shown in [Figure 4-15 \(A\)](#) is to be performed first with the R conductor grounded and repeated with the T conductor grounded. It is not necessary to repeat the metallic test if EUT symmetry can be demonstrated, that is, identical components and circuit layout are present at the T and R appearances of the EUT. In addition, the longitudinal test shown in [Figure 4-15 \(B\)](#) is to be performed.

For 4-wire interfaces, in addition to performing the metallic and longitudinal tests shown in [Figure 4-15 \(A\)](#) and [\(B\)](#), an additional pair-to-pair test is to be performed using the test circuit shown in [Figure 4-16](#). The 60-Hz voltage is applied to the T and R pair while the other pair (T<sub>1</sub> and R<sub>1</sub>) is grounded.

The 60-Hz voltage source of [Figure 4-15](#) and [Figure 4-16](#) shall have a maximum internal impedance of 2 ohms. The time-current characteristics of the EUT shall be determined by applying the 60-Hz open-circuit voltage of 600 V<sub>rms</sub> to the (A) test connections shown in [Table 4-1](#), with the EUT connected as shown in [Figure 4-15 \(A\)](#) and [\(B\)](#) and [Figure 4-16](#), as appropriate. The test shall be performed by applying a 60-Hz source with the following short-circuit currents:

- 2.2 and 2.6 A rms for up to 15 minutes. For these tests only, the use of the wiring simulator in [Figure 4-15 \(A\)](#) and [\(B\)](#) and [Figure 4-16](#) is not required. Results from the test at 2.2 A rms performed in accordance with [Table 4-10](#) of [Section 4.6.15](#) can be used in place of the test at 2.2 A rms in this section.
- 3, 3.75, 5, 7, 10, 12.5, 20, 25, and 30 A rms for up to 15 minutes.

The test begins by the application of the 60-Hz source at a short-circuit value of 2.2 A rms for 15 minutes and continues by repeating the 15-minute application of the 60-Hz source with each subsequent value of the short-circuit current until one of the following occurs:

1. Tests at all specified current values are performed.
2. The equipment interrupts the current or reduces the applied current to a value less than 50 mA for at least 1 minute. In this case, the test continues by proceeding to the application of the 60-Hz source at a short-circuit current of 7 and 30 A rms for 15 minutes.
3. As applicable, the wiring simulator fuse becomes open-circuited, the acceptable region of the time-current characteristic of [Figure 4-14](#) is exceeded, or the 26 AWG wire simulator becomes open-circuited or sufficiently hot to damage the cheesecloth.

For conditions 1 and 2, the equipment meets the criteria if

- As applicable, the wiring simulator fuse does not become open-circuited or the acceptable region of the time-current characteristic of [Figure 4-14](#) is not

exceeded, or the 26 AWG wire simulator becomes open-circuited or sufficiently hot to damage the cheesecloth, and

- The equipment does not become a fire, fragmentation, or electrical safety hazard as result of the application of the tests.

If condition 3 occurs, the EUT has permitted excessive current to flow and has failed the test.

The tests shall be applied as specified in [Section 4.6.2](#).

#### 4.6.15 Second-Level AC Power Fault Tests for Equipment To Be Located on Customer Premises and OSP Facilities (Type 3 and 5 Telecommunications Ports)

This section applies to telecommunications ports of network equipment that is to be located at OSP facilities or customer premises and intended to interface with the telecommunications OSP or to serve off-premises equipment (see Type 3 and 5 ports in [Appendix B](#)).

These second-level tests, which may be destructive, may be performed with the EUT operating at a subassembly level equivalent to the standard system configuration. When testing at the subassembly level, the backplane must be capable of handling the currents allowed by the circuit packs so the host does not become a fire hazard. Cheesecloth is to be applied as discussed in [Section 4.6.4](#) as the fire hazard indicator.

The resistors shown in [Figure 4-2](#) are to be selected to permit the current indicated in each test in [Table 4-10](#) to flow in each conductor under short-circuit conditions. The test generator shown in [Figure 4-2](#) is to be set to the voltage indicated in [Table 4-10](#) under open-circuit conditions.

During these tests, a wiring simulator on each energized conductor is to be placed between the voltage source and the EUT (connections similar to those shown in [Figure 4-15](#) and [Figure 4-16](#)). The use of the wire simulator is not required for tests 4 and 5.

For premises-type wiring, the wiring simulator consists of a fuse or device having a time-current characteristic at the upper limit of the acceptable region shown in [Figure 4-14](#). A Type MDQ 1-6/10A fuse or Type MDL 2.0A fuse, manufactured by Bussman Manufacturing Company or their equivalent, is acceptable.

**NOTE:** It is also permissible to use non-invasive time-current measurement techniques to determine compliance with the time-current characteristic of [Figure 4-14](#).

Where equipment is intended to be connected to the network using 26 AWG or coarser cable, and the manufacturer specifies the complete installation of the equipment from the network interface, a 1-foot section of No. 26 AWG copper wire may be used as the wiring simulator. The wiring simulator is to be connected to a representative installation, including wiring, connectors, cross-connect punchings, etc. The fire hazard for cable-connected equipment is indicated by the application of cheesecloth as described in [Section 4.6.4](#) not only to the EUT, but also to the representative installation, including the wiring simulator.

If the wiring simulator becomes open-circuited during the tests of [Table 4-10](#), the EUT has permitted excessive current to flow and has failed the test. Where a 26-gauge wire is used as the wiring simulator, the test is failed if the wiring simulator either becomes open-circuited or sufficiently hot to damage the cheesecloth.

If the series-type network equipment becomes open-circuited during test 4 of [Table 4-10](#), the series-type equipment shall be tested at a reduced current level just below the minimum current that causes the equipment to become open-circuited. The minimum current can be determined by repeating the test that causes the open-circuit with reduced currents.

Substantiating data provided by an NRTL as part of a successfully completed listing program is acceptable as an indication of compliance with Test Conditions 1a, 3, and 4 of [Table 4-10](#) and Test Condition 2 of [Table 4-9](#). Examples of acceptable listing standards are UL 1459<sup>[32]</sup> and UL 60950-1,<sup>[33]</sup> Test Conditions 2, 3, 4, and 5 of Annex NAC. It is not acceptable to base conformance on the “construction” method described in the listing programs. The actual tests shall be performed to be considered acceptable.

Network equipment that is intended for OSP and customer-premises applications and that meets the criteria of this section need not be analyzed according to [Section 4.6.12](#).

Network equipment that is intended for customer-premises intra-building application and that meets the criteria of this section need not be analyzed according to [Section 4.6.17](#).

---

**R4-28 [137]** As a result of the application of second-level ac power fault tests shown in [Table 4-10](#), the EUT (e.g., the surged telecommunications ports) including the host system **shall not** become a fire, fragmentation, or electrical safety hazard as described in [Section 4.6.1](#). In addition, the wiring simulator **shall not** interrupt the current during the tests of [Table 4-10](#).

---

**Table 4-10** Second-Level AC Power Fault (Telecommunications Port)

Test	Test for	Voltage <sup>1</sup> (Vrms)	Short-Circuit Current per Conductor (Amperes)	Duration	Test Connections per Table 4-1 <sup>2</sup>
1a	Secondary Contact	120	25	15 minutes	A
1b	Secondary Contact	277	25	15 minutes	A
2	Primary Contact	600	60	5 seconds	A
3	Short-Term Fault Induction	600	7	5 seconds	A
4	Long-Term Fault Induction	600	2.2 <sup>3</sup>	15 minutes	A
5	High- Impedance Induction	See Figure 4-13	See Figure 4-13	15 minutes	See Figure 4-13

Notes to *Table 4-10*:

1. All sources are 50 or 60 Hz sinusoidal.
2. Primary protectors removed for all tests.
3. For series-type network equipment connected to multiple terminating equipment, the maximum short-circuit per conductor current available from the generator is to be increased to 5 amperes. This is intended to simulate multiple terminating equipment ports being connected to a single series-type equipment port. Series-type network equipment ports that are connected to a single terminating equipment port are exempt from this note. The manufacturer shall provide sufficient evidence to indicate that the series-type equipment port will only be connected to a single terminating equipment port.

#### 4.6.15.1 Equipment Ports With Secondary Protection

**R4-29 [176]** If the equipment port under test contains a secondary protector with voltage-limiting device(s), tests 1, 3, and 4 of *Table 4-11*, or alternatively tests 2, 3, and 4 of *Table 4-11* **shall** be performed at the maximum operating peak threshold value of the voltage-limiting device(s). The applied rms voltage,  $V_s$  in *Table 4-11*, **shall** be  $0.707 \times$  the maximum operating peak threshold value of the voltage-limiting device. As the result of the application of any of these tests, the EUT (e.g., the surged telecommunications ports) including the host system **shall not** become a fire, fragmentation, or electrical safety hazard as described in *Section 4.6.1*.



**R4-30 [177]** If the equipment port under test contains a current-limiting device, test 5 of [Table 4-11](#) shall be performed at the maximum operating threshold value of the current-limiting device ( $I_s$  in [Table 4-11](#)) or 2.2A, whichever is lower. As the result of the application of the test, the EUT (e.g., the surged telecommunications ports) including the host system shall not become a fire, fragmentation, or electrical safety hazard as described in [Section 4.6.1](#).

The resistors shown in [Figure 4-2](#) are to be selected to permit the current indicated in each test in [Table 4-11](#) to flow in each conductor under short-circuit conditions. For tests 1, 3, and 4 of [Table 4-11](#), the generator resistance used during tests 2, 3, and 4 in [Table 4-10](#) should remain constant while the open-circuit voltage is reduced (i.e., the short-circuit current values are based on approximate values of generator resistances).

For tests 3 and 4 of [Table 4-11](#), a wire simulator on each energized conductor is to be placed between the voltage source and the EUT (connections similar to those shown in [Figure 4-15](#) and [Figure 4-16](#)). The wire simulator shall be the same used for the tests in [Table 4-10](#).

For **R4-29 [176]**, the voltage-limiting device(s) of the secondary protector are to be disabled or removed (if possible) from the port under test to prevent accidental operation. The maximum operating peak threshold value for a voltage-limiting device is the maximum voltage-limiting value under 50-Hz or 60-Hz conditions. For example, if the voltage-limiting value ranges from 280 to 350 V peak, the maximum operating peak threshold value is 350 V and the applied rms voltage ( $V_s$ ) is to be 248 Vrms. If the voltage-limiting secondary protection cannot be disabled or removed, the generator specified in test 4 of [Table 4-10](#) should be used for determining the applied rms voltage ( $V_s$ ). The voltage of the generator should be varied in the range of 100 to 600 V with incremental steps until the maximum applied voltage that would not operate the secondary voltage-limiting device is determined. The initial steps may be 100 V but it should be reduced as the applied voltage approaches the operation of the secondary protector.

Tests 3 and 4 of [Table 4-11](#) shall not be required if the current monitored during test 1 or 2 of [Table 4-10](#) does not exceed 50 mA for the first ten (10) seconds. The test report shall provide sufficient information, including the record of the measured current, to justify the exemption.

For **R4-30 [177]**, the maximum operating threshold value for a stand-alone current-limiting device is the maximum rated rms current level that it will carry for 15 minutes (not to exceed 2.2 amperes). The current-limiting device(s) of the secondary protector may be bypassed on the port under test to prevent accidental operation. If the current-limiting device is not bypassed or disabled, and the current-limiting device operates during the test, the test shall be repeated with the current-limiting device(s) of the secondary protector disabled or bypassed on the port under test.

The characteristics of the secondary voltage-limiting and current-limiting devices can be obtained by the manufacturer.



**Table 4-11** Second-Level AC Power Fault for Equipment Ports With Secondary Protection (Telecommunications Port)

Test	Voltage <sup>1</sup> (Vrms)	Short-Circuit Current per Conductor (Amperes)	Duration	Test Connections per Table 4-1 <sup>2</sup>
1	$V_s$	$V_s/272^{[3]}$	15 minutes	A
2	$V_s$	2.2	15 minutes	A
(Either Test 1 or 2 may be performed)				
3	$V_s$	$V_s/10^{[3]}$	5 seconds	A
4	$V_s$	$V_s/85^{[3]}$	5 seconds	A
5	600	$I_s$ (maximum of 2.2A)	15 minutes	A

Notes to *Table 4-11*:

1. All sources are 50 or 60 Hz sinusoidal.
2. Primary protectors removed for all tests.
3. The numeric values represent the approximate generator resistance used during the tests 2, 3, and 4 in *Table 4-10*. The same generator used during the tests 2, 3, and 4 in *Table 4-10* may be utilized for these tests with the rms voltage adjusted to  $V_s$ .

#### 4.6.15.2 Tests for Ungrounded Exposed Conductive Surfaces

For ungrounded exposed conductive surfaces, the following test shall be performed to ensure there is no potential breakdown up to and including 300 Vrms.

- A test voltage of 300 Vrms ac with a frequency range between 15 and 65 Hz shall be applied between ungrounded exposed conductive surfaces and grounded metal parts, any other ungrounded exposed conductive surface, and OSP telecommunications ports. Alternatively, dc voltages can be used for testing with a dc value equal to the peak of the rms voltage. All capacitors to grounded metal parts can be disconnected before testing if it is desired. All voltages shall be applied for 1 minute.

If the current at the test voltage does not exceed 0.15 mA, no further test is required and **R4-31 [138]** is considered met. If the current exceeds 0.15 mA, the following test shall be performed:

- Prior to the testing, connect the applicable wiring simulator to the paired-conductors of a telecommunications port. Connect the other side of the wiring simulator to the generator return (ground). Connect the equipment grounding means as described in Section 9 to the generator return (ground).

Prior to the testing, connect the output of a 277 Vrms source with a short-circuit current of 20A to any ungrounded exposed conductive surface on the equipment. Connect the ground connection of the equipment (if it has one) and any other ungrounded exposed conductive surface to the generator return (ground).

- Apply the 277 Vrms source for a 15-minute period.
- The EUT has not met **R4-31 [138]** if any of the following conditions occurs:
  - a. As applicable, the wiring simulator fuse becomes open-circuited, the acceptable region of the time-current characteristic of **Figure 4-14** is exceeded, or the 26 AWG wire simulator becomes open-circuited or sufficiently hot to damage the cheesecloth.
  - b. The EUT becomes a fire, fragmentation, or electrical safety hazard as a result of the application of the test.

---

**R4-31 [138]** The EUT including the host system **shall not** become a fire, fragmentation, or electrical safety hazard as described in **Section 4.6.1** when 60-Hz open-circuit voltage sources, 277 Vrms with a 20 A rms short-circuit current are applied for a 15-minute period between ungrounded exposed conductive surfaces and ground or any other ungrounded exposed conductive surface that may become incidentally grounded. The wiring simulator connected to telecommunications ports as described in this section **shall not** interrupt the current during the test. For this test, a single test on a representative location of similar exposed conductive surfaces **shall** be performed on one sample of EUT. This requirement is considered to be met if the EUT meets the dielectric breakdown test described in **Section 4.6.15.2**.

**R4-32 [139]** This requirement has been deleted.

---

#### 4.6.16 Second-Level AC Power Fault Tests for Series-Type Equipment To Be Located on Customer Premises and OSP Facilities (Type 3 and 5 Telecommunications Ports)

This section applies to telecommunications ports of series-type network equipment that is to be located at OSP facilities or customer premises (see Type 3 and 5 ports in **Appendix B**). The tests shall be applied as specified in **Section 4.6.2**.

Tests with the terminals open-circuited are performed identically to those for network equipment as described in **Section 4.6.15**. Tests with the terminals short-circuited are performed using the procedures of **Section 4.6.15**, with the exception that the wiring simulator is not used.

Second-level tests, which may be destructive, may be performed with the EUT operating at a subassembly level equivalent to the standard system configuration. When testing at the subassembly level, the backplane must be capable of handling the currents allowed by the series-type equipment so the host does not become a fire hazard. Cheesecloth is to be applied as discussed in **Section 4.6.4** as the fire hazard indicator.

---

**R4-33 [140]** As a result of the application of the second-level ac power fault tests shown in **Table 4-10**, series-type network equipment **shall not** become a fire, fragmentation,

or electrical safety hazard as described in Section 4.6.1. Where it is applicable, the wiring simulator **shall not** interrupt the current during the tests of Table 4-10.

#### 4.6.17 Second-Level Intra-Building AC Power Fault Tests for Equipment To Be Located on Customer Premises (Type 4 Telecommunications Port)

This test applies only to Type 4 ports of network equipment intended to be located within buildings that will neither interface with the telecommunications OSP nor serve off-premises equipment (see Appendix B). An example of such equipment might be a remote terminal located on customer premises and serving only telephones located on the premises (that is, no off-premises extensions). The test is to be applied to equipment ports that interface with paired telecommunications conductors — that is, T and R.

This second-level test, which may be destructive, may be performed with the EUT operating at a subassembly level equivalent to the standard system configuration. When testing at the subassembly level, the backplane must be capable of handling the currents allowed by the circuit packs so the host does not become a fire hazard. Cheesecloth is to be applied as described in Section 4.6.4 as the fire hazard indicator.

Tests are performed using a wiring simulator, which differs depending on the connecting means normally intended for the EUT. For equipment utilizing premises-type wiring such as RJ 11 jacks and modular cords, the wiring simulator is a fuse or device having a time-current characteristic at the upper limit of the acceptable region shown in Figure 4-14. A Type MDQ 1-6/10 A fuse or Type MDL 2.0 A, manufactured by Bussman Manufacturing Company or their equivalent, is acceptable. The wiring simulator shall not interrupt the current during the tests.

**NOTE:** It is also permissible to use non-invasive time-current measurement techniques to determine compliance with the time-current characteristic of Figure 4-14.

For equipment directly connected using cable, the wiring simulator is a section of copper wire representative of the minimum (finest) gauge cable specified for use with this equipment. When the wiring simulator consists of a copper wire, the cheesecloth shall also be applied to the wiring simulator.

**R4-34 [40]** As a result of the application of Test 1 shown in Table 4-8 conducted at 120 Vrms only, the EUT (e.g., the surged telecommunications ports) including the host system **shall not** become a fire, fragmentation, or electrical safety hazard as described in Section 4.6.1.

**NOTE:** This criterion also applies to equipment ports if the telecommunication cable is shielded and both ends of the shield are grounded.

**R4-35 [125]** In addition to the EUT itself not becoming a fire or electrical safety hazard the EUT **shall**, under 120 V ac power contact conditions, limit current to values that can be safely carried by customer-premises wiring, plugs, jacks, cross-connects, etc. This **shall** be demonstrated by the application of the wiring simulator as illustrated in Figure 4-15 and Figure 4-16, as appropriate.

**R4-36 [41]** Equipment or a subassembly that meets the requirements of this section, but does not meet, or is not intended to meet, the criteria of [Table 4-8](#), **shall** contain the following, or substantially similar, warning in the equipment installation documentation.

**WARNING:** The intra-building port(s) of the equipment or subassembly is suitable for connection to intrabuilding or unexposed wiring or cabling only. The intra-building port(s) of the equipment or subassembly **MUST NOT** be metallically connected to interfaces which connect to the OSP or its wiring. These interfaces are designed for use as intra-building interfaces only (Type 2 or Type 4 ports as described in GR-1089-CORE, Issue 4) and require isolation from the exposed OSP cabling. The addition of Primary Protectors is not sufficient protection in order to connect these interfaces metallically to OSP wiring.

**NOTE:** It is also permissible to use non-invasive time-current measurement techniques to determine compliance with the time-current characteristic of [Figure 4-14](#).

#### 4.7 Lightning Protection Tests for Equipment To Be Located in High-Exposure Customer Premises and OSP Facilities (Type 3 and 5 Telecommunications Ports)

This protection test applies to a very limited number of cases in which the lightning environments are more severe than those specified in [Section 4.6](#). Such severe lightning environments may occur at:

- Customer premises and OSP facilities predominantly fed by cable of less than 25 pairs with maximum operating loops of 1 kft (i.e., some Type 3 and 5 Ports)

The protection of equipment is achieved when either of the following conditions or a combination is met:

- The equipment causes the operation of the primary protection for surges that represent this severe electrical environment and the equipment has sufficient surge withstand capability for less severe surges, or
- The equipment has a surge withstand capability that is adequate to survive surges that represent this severe electrical environment.

Prior to starting testing, the maximum voltage-limiting value,  $V_L$ , of the primary protector needs to be specified. For the EUT that is designed to be protected by 3-mil carbon blocks and tested against [Section 4.6](#), the maximum voltage-limiting value,  $V_L$ , is 1000 V. For EUT tested against [Section 4.8](#), “Criteria for Equipment Interfacing With Agreed Primary Protection,” or [Section 4.9](#), “Criteria for Equipment With Integrated Primary Protection,” the specified value,  $V_L$ , for the primary voltage-limiting protection shall be the “minimum open-circuit voltage” value specified in the applicable Voltage-Limiting Category in Test 1 of [Table 4-13](#) or Test 1 of [Table 4-15](#), respectively.

The surge generator used for the tests shall have a charging open-circuit voltage,  $V_g$ , with a range of at least 400 V to 4000 V and be capable of delivering a short-circuit current of 500 A, 10/250  $\mu$ s surge at each output terminal with an open-circuit voltage

of 4000 V. The primary protector may optionally be placed in the test circuit shown in Figure 4-17. If the primary protector is placed in the test circuit of Figure 4-17, the protector shall have voltage limiting at a rate of rise of 1 kV/ $\mu$ s within 5% from the specified value,  $V_L$ .

If the primary protection is not placed in the test circuit and has a current-limiting protection or a series element, the lowest resistance value,  $R_C$ , of the current-limiting protection (e.g., 4 ohms for heat coils) should be series connected to the EUT port terminal (see Figure 4-17). The measured peak voltage,  $V_p$ , across the EUT terminal should include the voltage drop of the series resistance ( $R_C$ ) as shown in Figure 4-17. If the primary protector is used, it replaces  $R_C$  in the test circuit shown in Figure 4-17.

Using the test circuit in Figure 4-17, the generator voltage,  $V_o$ , for the repetitive impulse tests must be determined as required in Table 4-12. The determination procedure requires that the charging voltage of the generator,  $V_g$ , be increased in 200 V steps from the specified voltage-limiting value,  $V_L$ , of the primary protector until any of the following conditions occur:

- The terminal voltages to ground in Figure 4-17,  $V_{p1}$  and  $V_{p2}$ , reach the specified voltage-limiting,  $V_L$ , of the primary protector if the primary protector is not placed in the test circuit of Figure 4-17.
- The voltage-limiting devices of the primary protector operate if the primary protector is placed in the test circuit of Figure 4-17.
- The output of the generator reaches 4000 V.

As the measured  $V_p$  value approaches  $V_L$ , the nominal 200 V step size can be reduced to avoid excessive stress on the EUT. The value of  $V_o$  shall be determined in both impulse polarities, unless the worst-case polarity can either be established by analysis, or analysis establishes that the protection is not phase sensitive. The  $V_o$  value used shall be the highest  $V_o$  of the two terminals.

Using the value of  $V_o$  as determined above, the EUT must withstand ten (10) repetitions in each polarity as specified in Table 4-12. If a primary protection is used for determining  $V_o$ , it should be removed during the tests specified in Table 4-12. If the testing of Table 4-12 causes EUT damage and EUT does not operate properly as described in Section 4.6.1, then the EUT has failed this criterion.

---

**CO4-37 [178]** The manufacturer should specify in the test report and equipment documentation the required primary protection, voltage-limiting and current-limiting if it is necessary, with which the EUT passes this criterion. Upon the application of surge tests specified in Table 4-12, the EUT (e.g., surge telecommunications ports) including the host system should not be damaged and should continue to operate properly as described in Section 4.6.1.

---

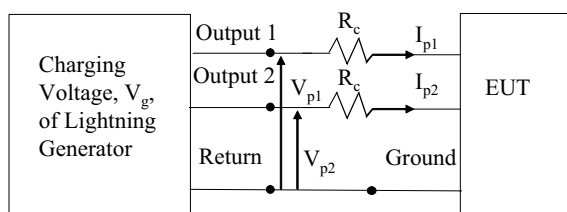
**Table 4-12** Protection Test Criteria for Equipment To Be Located on High-Exposure Customer Premises and OSP Facilities

Surge	Peak Voltage, (Volts)	Maximum Rise/Minimum Decay Time for Voltage and Current <sup>1</sup> (μs)	Repetitions, Each Polarity	Test Connections
1	$V_o$ , value as determined in Section 4.7	10/250	10	B

Notes to Table 4-12:

1. Double-exponential waveshape as defined in Appendix A. Maximum rise and minimum decay times apply to the voltage waveshape measured into an open circuit and to the current waveshape measured into a short circuit.

**Figure 4-17** Longitudinal Test Circuit for Equipment To Be Located on High-Exposure Customer Premises and OSP Facilities



Note:  $R_c$  is the resistance value of the current-limiting protection or series element that may be used in the primary protector

#### 4.8 Criteria for Equipment Interfacing With Agreed Primary Protection

This section applies to telecommunications ports that will be protected by a known defined primary protector other than 3-mil carbon block, agreed to between the manufacturer and the service provider. This section applies only to equipment intended to be located at the customer premises and non-CO-type facilities such as remote cabinets and other OSP locations (i.e., Type 3 and 5 ports in Appendix B). The criteria of this section does not apply to network equipment intended for deployment in CO-type facilities (i.e., Type 1 Ports). When applying this section, use lightning and power fault criteria for telecommunications ports specified in Section 4.6 as modified by this section. Equipment not using agreed primary protection shall meet the lightning and power fault criteria for telecommunications ports specified in Section 4.6.



Surge protection technologies other than carbon blocks include gas tubes, solid state or hybrids. Their characteristics are described in GR-974-CORE,<sup>[31]</sup> *Generic Requirements for Telecommunications Line Protector Units (TLPUs)*, or GR-1361-CORE,<sup>[34]</sup> *Generic Requirements for Gas Tube Protector Units (GTPUs)*. They may also include current-limiting devices. The surge protectors may have lower voltage limiting at various rate of rises than 3-mil carbon blocks. The agreed primary protection is defined in [Appendix D](#).

If the LEC indicates that the network equipment will be installed in customer and OSP facilities with a specified agreed primary protection other than carbon blocks (e.g., gas tube or solid state protectors), the manufacturer shall establish a process of consultation with the LEC to determine the type of agreed primary protection that is appropriate for the electrical environment.

---

**R4-38 [179]** The manufacturer **shall** consult with the LEC to define the agreed primary protection.

---

If the equipment has a telecommunications port(s) that is classified as Type 2 or Type 4 port, as described in [Appendix B](#), agreed primary protection is not required.

Equipment ports where agreed primary protection is specified always require primary protection regardless of the exposure status of the facility. Equipment manufacturers shall specify in the equipment documentation that installation of agreed primary protection is required for this equipment in all facilities regardless of their exposure classification (exposed or unexposed).

Compliance with values for the High-Voltage Limiting Category in [Table 4-13](#) also indicates compatibility with the Medium-Voltage Limiting Category and Low-Voltage Limiting Category. Compliance with values for the Medium-Voltage Limiting Category in [Table 4-13](#) also indicates compatibility with the Low-Voltage Limiting Category.

---

**R4-39 [180]** The network equipment port under test intended to be protected by agreed primary protection **shall** comply with all of the applicable first- and second-level criteria for equipment interfacing with the OSP in [Section 4.6](#) of GR-1089-CORE. The voltage and current parameter values specified in [Table 4-13](#) **shall** be substituted for the corresponding values specified in [Section 4.6](#). The voltage parameter values, such as minimum peak voltage and rms voltage, **shall** be selected from [Table 4-13](#). The parameter values such as waveform and duration that are not specified in [Table 4-13](#) **shall** be the same as specified in [Section 4.6](#). Tests that are not specified in [Table 4-13](#) and are applicable to Equipment Type 3 and 5 Ports in [Section 4.6](#) **shall** be performed. Tests **shall** be performed using the procedures described in [Section 4.6](#). The voltage-limiting and current-limiting characteristics of the surge protection and the parameters used for testing **shall** be included in the report.

**NOTE:** The voltage parameter values in [Table 4-13](#) are based on the voltage-limiting category (low, medium, and high) of the agreed primary protection as defined in GR-974-CORE.<sup>[31]</sup> The voltage parameter values for a primary protection that complies to GR-1361-CORE<sup>[34]</sup> are identical to the High-Voltage Limiting Category of [Table 4-13](#). The parameter values for the Specific Voltage Limiting Category are based on values agreed to between the manufacturer and the LEC.

**R4-40 [181]** The manufacturer's equipment documentation **shall** state that the network equipment is not intended for deployment in CO-type facilities and **shall** specify the voltage-limiting and current-limiting characteristics of the agreed primary protection in accordance with GR-974-CORE,<sup>[31]</sup> GR-1361-CORE,<sup>[34]</sup> or as agreed to between the manufacturer and LEC. Such characteristics are the maximum dc breakdown voltage and the voltage limiting of the surge protectors at different rate of rises (i.e., 0.1 V/ $\mu$ s, 100 V/ $\mu$ s, 1000 V/ $\mu$ s). For example, the documentation may state: "The network equipment is intended to be protected by the surge protection that meets GR-974-CORE and has the high-voltage-limiting category as specified in Section 4.11 of GR-974-CORE."

The documentation **shall** include the following warning:

**WARNING:** This product is intended to be protected by a surge protector that meets the applicable criteria of GR-974-CORE or GR-1361-CORE. Failure to utilize this appropriate surge protector could result in susceptibility to lightning surges or create a potential hazard due to power faults.

**Table 4-13** Parameter Values Used for Equipment Intended for Agreed Primary Protection (Sheet 1 of 2)

Test	Test Conditions in Section 4.6	Minimum Open-Circuit Voltage				Minimum Short-Circuit Current
		Low-Voltage Limiting Category	Medium-Voltage Limiting Category	High-Voltage Limiting Category	Specific Voltage Limiting Category <sup>1</sup>	
1.	Test 3 in Table 4-2	400 V peak	600 V peak	1000 V peak	Note 2	100 A peak
2.	Test 5 in Table 4-2	400 V peak	600 V peak	1000 V peak	Note 2	25 A peak
3.	Test 3 in Table 4-7	283 V <sub>rms</sub>	425 V <sub>rms</sub>	425 V <sub>rms</sub>	Note 3	1 A <sub>rms</sub> at 600 V <sub>rms</sub>
4.	Test 5 in Table 4-7 (see Note 4)	283 V <sub>rms</sub>	425 V <sub>rms</sub>	425 V <sub>rms</sub>	Note 3	See Figure 4-13
5.	Test 6 in Table 4-7	283 V <sub>rms</sub>	425 V <sub>rms</sub>	425 V <sub>rms</sub>	Note 3	0.5 A <sub>rms</sub>
6.	Test 7 in Table 4-7 (See Note 5)	440 V <sub>rms</sub>	440 V <sub>rms</sub>	440 V <sub>rms</sub>	440 V <sub>rms</sub>	2.2 A <sub>rms</sub>
7.	Test 7 in Table 4-7 (See Note 6)	283 V <sub>rms</sub>	425 V <sub>rms</sub>	425 V <sub>rms</sub>	Note 3	2.2 A <sub>rms</sub> at 440 V <sub>rms</sub>
8.	Test 8 in Table 4-7 (See Note 5)	600 V <sub>rms</sub>	600 V <sub>rms</sub>	600 V <sub>rms</sub>	600 V <sub>rms</sub>	3 A <sub>rms</sub>
9.	Section 4.6.14	283 V <sub>rms</sub>	425 V <sub>rms</sub>	425 V <sub>rms</sub>	Note 3	Test points as specified in Section 4.6.14
10.	Test 2 in Table 4-10 (See Note 5)	600 V <sub>rms</sub>	600 V <sub>rms</sub>	600 V <sub>rms</sub>	600 V <sub>rms</sub>	60 A <sub>rms</sub>
11.	Test 2 in Table 4-10 (See Note 6)	283 V <sub>rms</sub>	425 V <sub>rms</sub>	425 V <sub>rms</sub>	Note 3	60 A <sub>rms</sub> at 600 V <sub>rms</sub>



**Table 4-13** Parameter Values Used for Equipment Intended for Agreed Primary Protection (Sheet 2 of 2)

Test	Test Conditions in Section 4.6	Minimum Open-Circuit Voltage				Minimum Short-Circuit Current
		Low-Voltage Limiting Category	Medium-Voltage Limiting Category	High-Voltage Limiting Category	Specific Voltage Limiting Category <sup>1</sup>	
12.	Test 3 in Table 4-10 (See Note 5)	600 V <sub>rms</sub>	600 V <sub>rms</sub>	600 V <sub>rms</sub>	600 V <sub>rms</sub>	7 A <sub>rms</sub>
13.	Test 3 in Table 4-10 (See Note 6)	283 V <sub>rms</sub>	425 V <sub>rms</sub>	425 V <sub>rms</sub>	Note 3	7 A <sub>rms</sub> at 600 V <sub>rms</sub>
14.	Test 4 in Table 4-10 (see Note 7)	283 V <sub>rms</sub>	425 V <sub>rms</sub>	425 V <sub>rms</sub>	Note 3	2.2 A <sub>rms</sub>
15.	Test 5 in Table 4-10 (see Note 4)	283 V <sub>rms</sub>	425 V <sub>rms</sub>	425 V <sub>rms</sub>	Note 3	See Figure 4-13

*Notes to Table 4-13:*

- The voltage parameter values of the primary protection are agreed to between the manufacturer and LEC. If the voltage parameter of the agreed primary protection is less than the specified open-circuit voltage in any of the tests 1 and 2 of Table 4-7 and test 1 of Table 4-10, the test shall be performed first at the open-circuit voltage specified in Section 4.6 with the agreed primary protector in place, and repeated at reduced voltage as determined in Note 3 with the agreed primary protector removed.
- The voltage parameter value can be determined by using the following surge protector characteristic:
  - The maximum voltage limiting at a rate of rise at 1000 V/μs.

For example, if the agreed primary protection has a maximum voltage limiting of 875 V peak at 1000 V/μs, the minimum peak voltage is 875 V.
- The voltage parameter value can be determined by using the following surge protector characteristic:
  - The maximum voltage limiting at a rate of rise less than 0.1 V/μs or the maximum DC Breakdown Voltage. The rms voltage in Table 4-13 is 0.707 times the maximum voltage-limiting value or dc breakdown voltage.

For example, if the agreed primary protection has a maximum dc breakdown voltage of 400 V peak, the minimum rms voltage is 283 V<sub>rms</sub>.
- The voltage measured with respect to ground at V, V', V<sub>T</sub>, or V<sub>R</sub> in Figure 4-13 shall be equal to the values indicated in this table.
- The agreed primary protector shall be in place during these tests. The agreed primary protector used for the tests shall have voltage limiting at a rate of rise less than 0.1 V/μs or DC Breakdown Voltage within 5% from the maximum value specified in Note 3.
- These tests shall be performed with agreed primary protection removed only if the agreed primary protection operated during the corresponding tests with the

full applied voltage. For example, Test 8 of [Table 4-13](#) shall be performed only if the agreed primary protection operated during Test 7 of [Table 4-13](#).

7. The results from the test at 2.2 A rms performed during the fusing coordination in accordance with [Section 4.6.14](#) can be used in place of this test.

## 4.9 Criteria for Equipment With Integrated Primary Protection

This section applies to network telecommunication equipment that has integrated primary protection on ports that interface directly with the OSP (i.e., Type 3 and 5 Ports in [Appendix B](#)). Included under the umbrella of Equipment With Integrated Primary Protection (EIPP) is Equipment With Embedded Primary Protection (EEPP) (see [Appendix D](#) for definitions). If equipment has integrated primary protection, then circuits of the equipment can be divided into the following categories:

- Protected circuits – circuits “downstream” of the primary protection
- The primary voltage-limiting protection
- Unprotected circuits – circuits “upstream” of the primary voltage-limiting protection, including any current-limiting protection (for customer premises equipment this is usually called the “network side”)
- A cable stub, if provided with the equipment.

[Figure 4-18](#) illustrates the different categories of circuits. EIPP can include a discrete protector block for 5-pin protector units, have a discrete protection module that includes connections for wiring (i.e., station type protectors), or have primary protector components, such as gas tubes installed directly on the circuit board with the associated circuitry. If EIPP contains a discrete 5-pin protector block assembly, GR-2916-CORE,<sup>[35]</sup> *Generic Requirements for a 5-Pin Protector Block Assembly*, contains criteria that can be used to determine if the discrete 5-pin protector block assembly is appropriate. Manufacturers need to consult with the LEC to ensure the discrete 5-pin protector block assembly, or protector mounting mechanism in the equipment is appropriate for the application.

**NOTE:** The requirements of this section focus on electrical safety and EMC. Additional environmental, physical, and mechanical requirements may be relevant. Consult relevant Telcordia Generic Requirements for OSP apparatus, including NIDs.

The requirements of this section do not apply to devices covered by the following documents:

- GR-49-CORE, *Generic Requirements for Outdoor Telephone Network Interface Devices (NIDs)*<sup>[36]</sup>
- GR-2890-CORE, *Active Network Interface Device (Residential Gateway)*<sup>[37]</sup>
- GR-239-CORE, *Generic Requirements for Indoor Telephone Network Interface Devices (NIDs)*.<sup>[38]</sup>

---

**R4-41 [182]** EIPP composed solely of components that comply with Telcordia Generic Requirements applicable to each component is considered compliant with the requirements in this section.

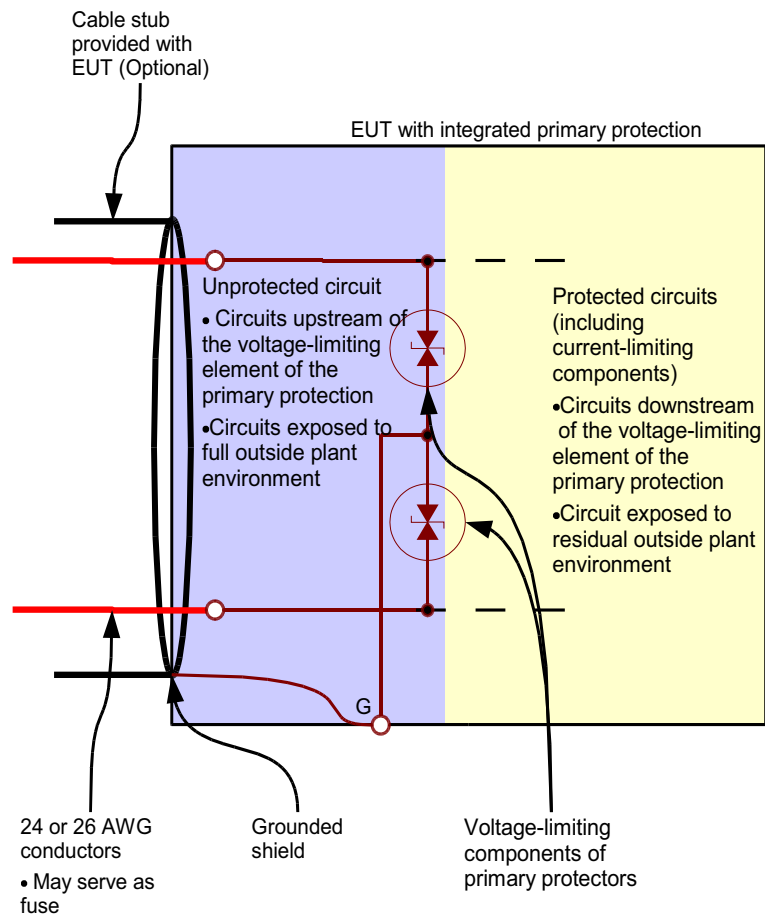
---

**NOTE:** For example, equipment composed of electronic circuits, a primary protector, protector block assembly, cable, wire, and enclosure is presumed compliant if these components comply with the following GRs (other GRs may apply to the same equipment):

- GR-1089-CORE for the protected electronic circuits
- GR-974-CORE<sup>[31]</sup> or GR-1361-CORE<sup>[34]</sup> for the primary protectors
- GR-2916-CORE<sup>[35]</sup> for the 5-pin protector block assembly
- GR-421-CORE, <sup>[39]</sup> *Generic Requirements for Metallic Telecommunications Cables*, for the cable
- GR-492-CORE, <sup>[40]</sup> *Generic Requirements for Metallic Telecommunications Wire*, for wire
- TR-TSY-000056, <sup>[41]</sup> *Repeater Housings for T1, T1C, T1D, and T1G Carrier Systems*, or GR-487-CORE, <sup>[42]</sup> *Generic Requirements for Electronic Equipment Cabinets*, for enclosure.

Certain criteria of GR-2916-CORE<sup>[35]</sup> may not be relevant to this application. Examples of these criteria that may not be relevant include termination capacity, connectorized input, and stub cable.

**Figure 4-18** Illustration of Components and Circuits in EIPP



#### 4.9.1 Equipment Classification

Application of the requirements for EIPP depends on proper classification of such equipment with respect to its intended installation and its ability to contain fusing. This subsection provides the relevant categories. EIPP is not suitable for installation in COs and other controlled environments such as EEEs.

**R4-42 [183]** EIPP installation documentation **shall** contain the following, or substantially similar, warning:

**WARNING:** This equipment contains integrated primary protection. This equipment is not suitable for installation in CO and network locations that contain other primary protection for OSP cable, such as EEEs (e.g.,

CEVs, and huts). The equipment may be located in EECs where appropriate installation practices are used (For example, installation should not employ a separate primary protector for the equipment, appropriate cabling should be run to the equipment, etc.).

**WARNING:** For the purposes of determining placement and location of fuse links or fuse cable, the equipment shall be treated as a fuse-less protector, regardless of any capability to provide fusing.

**R4-43 [184]** The manufacturer **shall** classify EIPP as being suitable for one or more of the following installation conditions:

1. Suitable for OSP installation and having or housing parts capable of acting as outside-plant fuse links inside the EUT.
2. Suitable for OSP installation and not capable of having or housing parts that can act as outside-plant fuse links inside the EUT.
3. Suitable for installation at customer premises and having or housing parts capable of acting as outside-plant fuse links inside the EUT.
4. Suitable for installation at customer premises and not capable of having or housing parts that can act as outside-plant fuse links inside the EUT.

Table 4-14 summarizes the requirements for the various classifications of equipment.

**Table 4-14** Applicability of EIPP Requirements

Requirement	EIPP Classification			
	1	2	3	4
Section 4.9.2, "Protector Requirements," except <b>R4-46 [187]</b>	Y	Y	Y	Y
Section 4.9.2, "Protector Requirements," <b>R4-46 [187]</b>			Y	Y
Section 4.9.3, "Lightning Surge and Power Fault Tests for Protected Circuits."	Y	Y	Y	Y
Section 4.9.4.1, "Fusing Coordination for Circuits Suitable for Fusing."	Y		Y	
Section 4.9.4.2, "Fusing Coordination Test for Circuits Not Acting as Fuse Links."		Y		Y
Section 4.9.5, "Dielectric Withstand."	Y	Y	Y	Y
Section 4.9.6, "Stub Cable Requirements."	Y	Y <sup>1</sup>	Y	Y <sup>1</sup>
Section 4.9.7, "AC Power Fault Immunity."	Y		Y	
Section 4.9.8, "Lightning Surge Tests."	Y	Y	Y	Y

Notes to *Table 4-14*:

1. Applicable if fusing occurs within the stub cable during fusing coordination tests.

## 4.9.2 Protector Requirements

This section provides requirements related to installation or provision of primary protection.

- R4-44 [185]** The protector units installed or shipped with the EIPP **shall** be Listed. Embedded primary protector components **shall** be Listed or Recognized.

**NOTE:** Examples of appropriate Listing standards for primary protection are UL 497<sup>[43]</sup> and UL 497C.<sup>[44]</sup>

- R4-45 [186]** EIPP **shall** be Listed. The Listing program **shall** address requirements related to primary protection.

The following requirement is intended to facilitate compliance with sections 800.90(A) and 830.90(B) of the NEC.<sup>[49]</sup>

**NOTE:** Manufacturers are strongly advised to consult the LEC to determine the proper classification of the equipment with respect to the NEC.

- R4-46 [187]** EIPP classified as suitable for installation at the customer premises under items 3 or 4 in **R4-49 [190]**, **shall** contain or have provisions for installation of a Listed primary protector or be Listed as a primary protector. As an exception to this, EIPP that is a part of a Network-powered Broadband Communication System covered by NEC Article 830 may contain embedded protection provided the EIPP is Listed for this application.

The following are other requirements for primary protection.

- R4-47 [188]** EIPP **shall** be marked or labelled externally to indicate that it contains primary protection.

- R4-48 [189]** The primary protector assembly or discrete protector, such as a gas tube, supplied with the equipment **shall** be appropriate for the application based on relevant performance specifications. Appropriateness may be demonstrated by data supplied by the protector manufacturer or testing.

**NOTE:** Examples of specifications for primary protector assemblies are Telcordia GR-974-CORE<sup>[31]</sup> or GR-1361-CORE.<sup>[34]</sup> If the EUT contains an embedded primary protector other than a 5-pin protector, a subset of requirements of GR-974-CORE or GR-1361-CORE may be applicable to that type of protector assembly. Manufacturers are expected to consult with the LEC to ensure the protector(s) is appropriate for the application.

- R4-49 [190]** The manufacturer **shall** describe in the equipment documentation the protector characteristics, such as voltage limiting, needed to determine that primary protection is appropriate for the electrical environment.

### 4.9.3 Lightning Surge and Power Fault Tests for Protected Circuits

The requirements in this section apply to protected circuits (on the equipment side) of the voltage-limiting element of the primary protection. Tests are to be performed with the voltage-limiting element in place or removed as indicated in the requirement. In all cases, the tip and ring conductors are to remain continuous across the primary protector.

Compliance with values for the High-Voltage Limiting Category also indicates compatibility with the Medium-Voltage Limiting Category and Low-Voltage Limiting Category. Compliance with values for the Medium-Voltage Limiting Category also indicates compatibility with the Low-Voltage Limiting Category.

**R4-50 [191]** The EIPP port under test **shall** comply with all of the applicable first- and second-level criteria for equipment interfacing with the OSP in Section 4.6 of GR-1089-CORE with the voltage-limiting elements of primary protectors removed or disabled (except those tests where primary protection is specified as left in place). Current-limiting elements of primary protection are allowed to remain in the circuit during this testing. The voltage and current parameter values specified in Table 4-15 **shall** be substituted for the corresponding values specified in Section 4.6. The voltage and current parameter values, such as minimum peak value and rms value, **shall** be selected from Table 4-15. The parameter values such as waveform and duration that are not specified in Table 4-15 **shall** be the same as specified in Section 4.6. Tests that are not specified in Table 4-15 and are applicable to Equipment Type 3 and 5 Ports in Section 4.6 **shall** be performed. The tests described in Section 4.6.14 **shall not** be performed. Tests **shall** be performed using the procedures described in Section 4.6. The voltage-limiting and current-limiting characteristics of the surge protection and the parameters used for testing shall be included in the report.

**NOTE:** The voltage parameter values in Table 4-15 are based on the voltage-limiting category (low, medium, and high) of the integrated primary protection as defined in GR-974-CORE.<sup>[31]</sup> The voltage parameter values for a primary protection that complies to GR-1361-CORE<sup>[34]</sup> are identical to High-Voltage Limiting Category of Table 4-15. The parameter values for the Specific Voltage Limiting Category are based on values agreed to between the manufacturer and the LEC.

**Table 4-15** Parameter Values Used for Equipment With Integrated Primary Protection (Sheet 1 of 2)

Test	Test Conditions in Section 4.6	Minimum Open-Circuit Voltage				Minimum Short-Circuit Current
		Low-Voltage Limiting Category	Medium-Voltage Limiting Category	High-Voltage Limiting Category	Specific Voltage Limiting Category <sup>1</sup>	
1.	Test 3 in Table 4-2	400 V peak	600 V peak	1000 V peak	Note 2	100 A peak
2.	Test 5 in Table 4-2	400 V peak	600 V peak	1000 V peak	Note 2	25 A peak
3.	Test 3 in Table 4-7	283 V <sub>rms</sub>	425 V <sub>rms</sub>	425 V <sub>rms</sub>	Note 3	1 A <sub>rms</sub> at 600 V <sub>rms</sub>

**Table 4-15** Parameter Values Used for Equipment With Integrated Primary Protection (Sheet 2 of 2)

Test	Test Conditions in Section 4.6	Minimum Open-Circuit Voltage				Minimum Short-Circuit Current
		Low-Voltage Limiting Category	Medium-Voltage Limiting Category	High-Voltage Limiting Category	Specific Voltage Limiting Category <sup>1</sup>	
4.	Test 5 in Table 4-7 (see Note 4)	283 V <sub>rms</sub>	425 V <sub>rms</sub>	425 V <sub>rms</sub>	Note 3	See Figure 4-13
5.	Test 6 in Table 4-7	283 V <sub>rms</sub>	425 V <sub>rms</sub>	425 V <sub>rms</sub>	Note 3	0.5 A <sub>rms</sub>
6.	Test 7 in Table 4-7 (See Note 5)	440 V <sub>rms</sub>	440 V <sub>rms</sub>	440 V <sub>rms</sub>	440 V <sub>rms</sub>	2.2 A <sub>rms</sub>
7.	Test 7 in Table 4-7 (See Note 6)	283 V <sub>rms</sub>	425 V <sub>rms</sub>	425 V <sub>rms</sub>	Note 3	2.2 A <sub>rms</sub> at 440 V <sub>rms</sub>
8.	Test 8 in Table 4-7 (See Note 5)	600 V <sub>rms</sub>	600 V <sub>rms</sub>	600 V <sub>rms</sub>	600 V <sub>rms</sub>	3 A <sub>rms</sub>
9.	Test 2 in Table 4-10 (See Note 5)	600 V <sub>rms</sub>	600 V <sub>rms</sub>	600 V <sub>rms</sub>	600 V <sub>rms</sub>	60 A <sub>rms</sub>
10.	Test 2 in Table 4-10 (See Note 6)	283 V <sub>rms</sub>	425 V <sub>rms</sub>	425 V <sub>rms</sub>	Note 3	60 A <sub>rms</sub> at 600 V <sub>rms</sub>
11.	Test 3 in Table 4-10 (See Note 5)	600 V <sub>rms</sub>	600 V <sub>rms</sub>	600 V <sub>rms</sub>	600 V <sub>rms</sub>	7 A <sub>rms</sub>
12.	Test 3 in Table 4-10 (See Note 6)	283 V <sub>rms</sub>	425 V <sub>rms</sub>	425 V <sub>rms</sub>	Note 3	7 A <sub>rms</sub> at 600 V <sub>rms</sub>
13.	Test 4 in Table 4-10	283 V <sub>rms</sub>	425 V <sub>rms</sub>	425 V <sub>rms</sub>	Note 3	2.2 A <sub>rms</sub>
14.	Test 5 in Table 4-10 (See Note 4)	283 V <sub>rms</sub>	425 V <sub>rms</sub>	425 V <sub>rms</sub>	Note 3	See Figure 4-13

*Notes to Table 4-15:*

1. The voltage parameter values of the integrated primary protection are specified by the manufacturer. If the voltage parameter of the integrated primary protection is less than the specified open-circuit voltage in any of the tests 1 and 2 of Table 4-7 and test 1 of Table 4-10, the test shall be performed first at the open-circuit voltage specified in Section 4.6 with the integrated primary protector in place, and repeated at reduced voltage as determined in Note 3 with the integrated primary protector removed.
2. The voltage parameter value can be determined by using the following surge protector characteristic:
  - The maximum voltage limiting at a rate of rise at 1000 V/μs.

For example, if the integrated primary protection has a maximum voltage limiting of 875 V peak at 1000 V/μs, the peak voltage is 875 V.
3. The voltage parameter value can be determined by using the following surge protector characteristic:



- The maximum voltage limiting at a rate of rise less than  $0.1 \text{ V}/\mu\text{s}$  or the maximum DC Breakdown Voltage. The rms voltage in Table 4-15 is 0.707 times the maximum voltage-limiting value or dc breakdown voltage.

For example, if the integrated primary protection has a maximum dc breakdown voltage of 400 V peak, the rms voltage is 283 Vrms.

4. The voltage measured with respect to ground at  $V$ ,  $V'$ ,  $V_T$ , or  $V_R$  in Figure 4-13 shall be equal to the values indicated in this table.
5. The integrated primary protector shall be in place during these tests.
6. These tests shall be performed with the voltage-limiting element of integrated primary protection removed or disabled only if the voltage-limiting element of integrated primary protection operated during the corresponding tests with the full applied voltage. For example, Test 8 of Table 4-15 shall be performed only if the integrated primary protection operated during Test 7 of Table 4-15.

#### 4.9.3.1 Overcurrent Protection Coordination Test for Protected Circuits

The requirements in this section apply to the protected circuits. Tests are to be performed with the voltage-limiting element in place. In all cases, the tip and ring conductors are to remain continuous across the primary protector.

**R4-51 [192]** The protected circuit in the EUT **shall not** become a fire, fragmentation, or electrical safety hazard as a result of the application of each of the following 60-Hz short-circuit currents on each conductor:

- 2.6, 3, 3.75, 5, 7, 10, 12.5, 20, 25, and 30 A rms for up to 15 minutes

The open-circuit voltage for each test **shall** be 600 V rms. The test begins by the application of a 60-Hz source at a short-circuit value of 2.6 A rms for 15 minutes and continues by repeating the 15-minute application of the 60-Hz source with each subsequent value of the short-circuit current until one of the following occurs:

1. Tests at all specified current values are performed.
2. The primary protection operates. If this cannot be determined, the test continues until all specified current values are performed.

One protected circuit **shall** be analyzed for each test condition.

#### 4.9.4 Fusing Coordination for Unprotected Circuits

This section provides fusing coordination requirements for

- Equipment having or housing parts capable of acting as outside-plant fuse links inside or as part of the equipment as described in Section 4.9.4.1, and
- Equipment not capable and not housing parts capable of acting as outside-plant fuse links inside or as part of the equipment as described in Section 4.9.4.2.

Equipment that is not tested to [Section 4.9.4.2](#) or does not meet the requirements of [Section 4.9.4.2](#) is classified as having or housing parts capable of acting as outside-plant fuse links inside or as part of the equipment and must meet all requirements relevant for this classification.

#### 4.9.4.1 Fusing Coordination for Circuits Suitable for Fusing

The requirements of this section apply to equipment having or housing parts capable of acting as outside-plant fuse links inside or as part of the equipment. These requirements help verify that the enclosure of the EUT can safely contain conductor fusing that can occur during severe power faults. This requirement can be met in one of the following ways:

- Performing EUT fusing coordination tests of [Section 4.9.4.1.1](#).
- Using an enclosure suitable for fusing in accordance with [Section 4.9.4.1.2](#).

##### 4.9.4.1.1 Fusing Coordination Test for Circuits Suitable for Fusing

The requirements in this section generally apply to the unprotected circuits (on the OSP side). If the primary protection operated during the tests of [Section 4.9.3.1](#), the voltage-limiting element of the primary protection is to be replaced by a short circuit and the protected circuit is allowed to be removed from the EUT. In case of 5-pin protector units, the short circuit can be accomplished by replacing the protector units with specially-prepared protector units that have all tip and ring connectors shorted to ground. However, if it cannot be determined that the primary protection operated during tests of [Section 4.9.3.1](#), the protected circuits and the primary protector are to remain in the EUT. The circuit under test is to include all grounding conductors used to connect primary protection to the grounding means of the EUT including the EUT grounding terminal.

---

**R4-52 [193]** The unprotected circuit **shall not** become a fire, fragmentation, or electrical safety hazard as a result of conducting the currents specified in [Table 4-16](#) at the specified durations. The unprotected circuit, including the cable stub, is permitted to open the circuit and interrupt the current during the test.

The duration corresponding to 24 AWG stub cable **shall** be used for EUT that does not have a factory-connected stub cable. If EUT has a factory-connected stub cable, then duration corresponding to 24 or 26 AWG stub cable **shall** be chosen depending on the size of conductors in the stub cable. The duration corresponding to 24 AWG stub cable **shall** be used for EUT that has a factory-connected stub cable coarser than 24 AWG. If EIPP has a factory-connected stub cable and the EIPP is intended for installation on Customer Premises, the stub cable **shall** consist of 26 AWG conductors.

The open-circuit voltage for each test **shall** be at least 3000 Vrms at 95% power factor or higher. Three (3) circuits **shall** be used for each test condition. The fire hazard indicator described in [Section 4.6.4](#) is to be used for the EUT and the stub cable.

**Table 4-16** Fusing Coordination for Unprotected Circuits Suitable for Fusing

Test Conditions	Conductors Powered	Short Circuit Current Per Conductor (A rms)	Duration of Current Flow	
			24 AWG Stub Cable	26 AWG Stub Cable
1	6 (3 adjacent prs.)*	5	15 min	15 min
2	6 (3 adjacent prs.)*	10	15 min	15 min
3	1	30	15 min	15 min
4	1	60	3 sec	0.5
5	1	120	0.6 sec	0.12
6	1	350	0.04 sec	0.014

\* Three pairs are maximum; use 1 and 2 pairs for one- or two-pair protectors.

#### 4.9.4.1.2 Enclosure Suitable for Fusing

This section provides criteria for determining if the enclosure is suitable to contain fusing. The EUT in an enclosure qualified to this section is not required to undergo the tests of [Section 4.9.4.1.1](#).

**R4-53 [194]** The EIPP enclosure **shall** be made of metal. The minimal thickness of the enclosure including doors and covers **shall not** be less than 0.0356 inches including manufacturing tolerances (i.e., 20-gauge steel).

**R4-54 [195]** The EIPP enclosure for EIPP suitable for outside-plant installation only **shall** be permitted to be made of polymeric materials. The minimal thickness of the enclosure including doors and covers **shall not** be less than 0.125 in. Parts of the enclosure within 4 inches of integrated primary protectors or conductive parts of the unprotected circuit **shall** be constructed of polymeric material rated CSA 0.17 5VA and UL 94-5VA.

**R4-55 [196]** The enclosure **shall not** contain vents or openings.

**R4-56 [197]** The enclosure material, including seals and gaskets **shall** be suitable for the OSP environment.

**NOTE:** Typical GRs for determining suitability include GR-487-CORE,<sup>[42]</sup> GR-2834-CORE,<sup>[45]</sup> and TR-NWT-000056.<sup>[41]</sup>

**R4-57 [198]** The enclosure **shall** be capable of withstanding a 12-gauge shotgun blast without penetration of the enclosure wall by any pellets. As a result of this test, the

enclosure **shall** not have openings (holes) between the outside and the inside of the enclosure.

The EIPP enclosure **shall** be subjected to a blast from a 2-3/4 inch, maximum-load, 12-gauge shotgun shell fired from a 28-inch modified choke barrel. A 1-ounce or 1-1/8 ounce (as available) load, No. 6 steel shot load **shall** be fired at a distance of 15 m (50 ft.) perpendicular to EUT surfaces that enclose the unprotected circuits, where

- 2-3/4 inch = length of shot shell
- Maximum load = universal measure of gunpowder load within shot shell
- 28-inch = length of modified choke shotgun barrel
- 1-ounce (or 1-1/8 ounce) = weight of steel shot load within shot shell
- No. 6 = size of steel shot (2.79 mm or 0.110 inch diameter).

**NOTE:** Portions of this test are not required if the relevant surfaces of the EUT enclosure have been tested and found compliant with the Firearms Resistance test as part of a test program to other Telcordia GRs that provide an equivalent requirement.

#### 4.9.4.2 Fusing Coordination Test for Circuits Not Acting as Fuse Links

The requirements of this section apply to equipment not capable and not housing parts capable of acting as outside-plant fuse links inside or as part of the equipment.

The requirements in this section generally apply to the unprotected circuits (on the OSP side). If the primary protection operated during the tests of [Section 4.9.3.1](#), the voltage-limiting element of the primary protection is to be replaced by a short circuit and the protected circuit is allowed to be removed from the EUT. In case of 5-pin protector units, the short circuit can be accomplished by replacing the protector units with specially-prepared protector units that have all tip and ring connectors shorted to ground. However, if it cannot be determined that the primary protection operated during tests of [Section 4.9.3.1](#), the protected circuits and the primary protectors are to remain in the EUT. The circuit under test is to include all grounding conductors used to connect primary protection to the grounding means of the EUT including the EUT grounding terminal.

**R4-58 [199]** The unprotected circuit **shall** be capable of conducting the currents specified in [Table 4-17](#) for the specified durations without becoming a fire, fragmentation, or electrical safety hazard. In addition, at the conclusion of the tests 1, 2, and 3, the circuits upstream of the voltage-limiting element of the primary protection **shall not** be damaged or degraded. At the conclusion of all tests, a short circuit **shall** remain between each input terminal of the EUT and ground.

The duration corresponding to 24 AWG stub cable shall be used for EUT that does not have a factory-connected stub cable. If EUT has a factory-connected stub cable, then duration corresponding to 24 or 26 AWG stub cable shall be chosen depending on the size of conductors in the stub cable. The duration corresponding to 24 AWG stub cable shall be used for EUT that has a factory-connected stub cable coarser

than 24 AWG. If EIPP has a factory-connected stub cable and the EIPP is intended for installation on Customer Premises, the stub cable shall consist of 26 AWG conductors.

The 26 AWG or coarser conductors of the stub cable are permitted to fuse open during the test. This fusing shall be permitted within the stub cable. Fusing of the stub cable conductors within the EUT enclosure shall not be permitted. If fusing occurs within the stub cable, the stub cable shall meet the requirement of **R4-60 [201]** and **R4-61 [202]**.

The open-circuit voltage for each test shall be sufficient to generate the required current. Three (3) circuits shall be used for each test condition. The fire hazard indicator described in **Section 4.6.4** is to be used for the EUT and the stub cable. The test source is to be connected to the EUT with 22 AWG or coarser conductors if a EUT stub cable is not provided.

**Table 4-17** Fusing Coordination for Unprotected Circuits Not Acting as Fuse Links

Test Conditions	Conductors Powered	Short Circuit Current per Conductor (A rms)	Duration of Current Flow	
			24 AWG Stub Cable	26 AWG Stub Cable
1	6 (3 adjacent prs.)*	5	15 min	15 min
2	6 (3 adjacent prs.)*	10	15 min	15 min
3	1	30	15 min	15 min
4	1	60	3 sec	0.5
5	1	120	0.6 sec	0.12
6	1	350	0.04 sec	0.014

\* Three pairs are maximum; use 1 and 2 pairs for one- or two-pair protectors.

#### 4.9.5 Dielectric Withstand

The requirements in this section apply to the unprotected circuits of the EUT. The test is to be performed with the primary protection removed. In case of 5-pin protector units, this can be accomplished by replacing the protector units with specially-prepared protector units that have the voltage-limiting elements (arrestors) removed. The protected circuits shall be disconnected during this testing. If it is not possible to disconnect the protected circuits, then it is permitted to remove components that bridge insulation between conductors or between conductors and enclosure, other than capacitors, during dielectric strength testing.

**NOTE:** The dielectric strength test of this section is not required if equivalent tests have been performed and found compliant as part of a Listing program. If a particular mode has not been tested during the Listing program, then only this mode is to be tested for this section.

---

**R4-59 [200]** The unprotected circuit **shall** be capable of withstanding a test voltage of 1500 V dc or 1000 V rms applied between each electrically-isolated circuit and all other electrically-isolated circuits and grounded metal parts. Tip and ring conductors of each unique electrically-isolated circuit **shall** be shorted together. All capacitors to grounded metal parts can be disconnected before testing if it is desired. All semiconductors including voltage-limiting devices and discharge resistors that provide a path to ground **shall** be disconnected before testing.

---

To perform the test, the voltage applied to the test terminals shall be gradually increased from 0 to the maximum value during a 30-second time interval and then applied continuously for 1 minute. The current shall not exceed 0.15 mA at any time during this 90-second time interval.

#### 4.9.6 Stub Cable Requirements

The requirements in this section apply if the EUT has a factory-connected stub cable. The requirements of this section apply to equipment having or housing parts capable of acting as outside-plant fuse links inside or as part of the equipment. In addition, The requirements of this section apply to equipment not capable and not housing parts capable of acting as outside-plant fuse links inside or as part of the equipment if fusing occurs within the stub cable during the fusing coordination tests in [Section 4.9.4.2](#).

---

**R4-60 [201]** The stub cable supplied with the equipment **shall** be appropriate for the application based on relevant performance specifications. Appropriateness may be demonstrated by data supplied by the protector manufacturer or testing.

**NOTE:** An example of specifications for cables is Telcordia GR-421-CORE.<sup>[39]</sup> Manufacturers are expected to consult with the LEC to ensure the protector(s) is appropriate for the application.

**R4-61 [202]** The stub cable **shall** have all conductors under a grounded metal shield or metal EUT enclosure. The plastic core wrap and the corrugated coated/uncoated metallic shield as well as the PVC sheath **shall** terminate in the EUT entrance bushing. The conductors **shall** be directed through the enclosure or a separate fusing chamber, if provided, and terminated.

The bushing **shall** meet UL 746C<sup>[46]</sup> five-inch flame test.

The stub cable **shall** be fastened to the EUT enclosure in a manner that provides a positive ground and is able to withstand a pulling force equal to 30 pounds of pull for 1 minute when applied in the downward direction at 2 feet from the stub termination in all directions.

---

#### 4.9.7 AC Power Fault Immunity

The requirements of this section apply to equipment having or housing parts capable of acting as outside-plant fuse links inside or as part of the equipment. The requirements in this section apply to the unprotected circuits (on the OSP side) with

the voltage-limiting element replaced by a short circuit. In case of 5-pin protector units, the short circuit can be accomplished by replacing the protector units with specially-prepared protector units that have all tip and ring connectors shorted to ground. The protected circuits shall not be required to be populated during this testing. The circuit under test is to include all grounding conductors used to connect primary protection to the grounding means of the EUT including the EUT grounding terminal.

**R4-62 [203]** The unprotected circuits **shall not** be damaged and **shall** continue to operate properly after the application of the 60-Hz currents of [Table 4-18](#). A total of three (3) protected circuits shall be analyzed for each condition.

**NOTE:** This test is not required if compliance with these requirements was demonstrated during the fusing coordination test for unprotected circuits.

**Table 4-18 AC Power Fault Immunity**

Test	Short-Circuit Current per Line Conductor	Duration	Number of Repetitions	Test Connection
1	10A rms	1 s	2	B
2	5A rms	15 min	1	B

#### 4.9.8 Lightning Surge Tests

This test applies to the EUT with the primary protection in place. This test is not required if [Section 4.9.8.1](#) applies. This test is to be performed for EEPP. The test is also to be performed for EIPP that contains a protector block or holder that has not been previously evaluated and found compliant to the same test in the relevant Generic Requirements.

**R4-63 [204]** EUT **shall not** become a fire, fragmentation, or safety hazard after application of second-level surge tests in [Table 4-19](#). The fire hazard indicator described in [Section 4.6.4](#) is to be used for the EUT and the stub cable. If the EUT has more than 10 protector positions, a total of 10 protector positions **shall** be tested. If the EUT has less than 10 protector positions, all positions **shall** be tested.



**Table 4-19** Lightning Surges for Severe Climatic Conditions

Surge Level	Minimum Open Circuit Voltage	Current Waveshape $\mu$ s	Short Circuit Current per Conductor	Repetitions Each Polarity	Surge Applied to
Second Level	$\pm 5000$ V	8/20	10,000 A	1	Each OSP terminal of a representative tip and ring pair, simultaneously, with respect to ground

4.9.8.1 Lightning Surge Tests for Severe Climatic Conditions

The requirements in this section apply to EUT suitable for customer premises (classification 3 and 4) that interfaces with eight or fewer OSP conductors. The test applies to the EUT with the primary protection in place. These requirements cover environments more severe than those of a normal environment (i.e., higher humidity, high lightning activity, atmosphere, and exposure to contaminants).

**CR4-64 [205]** The EUT **shall not** be damaged and **shall** continue to operate properly after application of first-level surge tests in [Table 4-20](#). All protector positions shall be tested.

**CR4-65 [206]** The EUT **shall not** become a fire, fragmentation, or safety hazard after application of second-level surge tests in [Table 4-20](#). The fire hazard indicator described in [Section 4.6.4](#) is to be used for the EUT and the stub cable. All protector positions **shall** be tested.

**Table 4-20** Lightning Surges for Severe Climatic Conditions

Surge Level	Minimum Open Circuit Voltage	Current Waveshape $\mu$ s	Short Circuit Current per Conductor	Repetitions Each Polarity	Surge Applied to
First Level	$\pm 3000$ V	10/250	2000 A	1	T to R single pair only
Second Level	$\pm 5000$ V	8/20	20,000 A	1	T to R single pair only

4.10 Criteria for Equipment Interfacing With Coaxial Cable Ports

These criteria apply to broadband communications equipment ports that interface with outside-plant coaxial cable for delivery of broadband services (Port Type 1, 3, and 5) under the provisions of NEC Article 830.<sup>[49]</sup> Broadband communications equipment are defined in [Appendix D](#). These criteria that interface with OSP cable are not intended for conventional telecommunications services, such as DS3.



Section 4.10.5 addresses equipment ports interfacing with intrabuilding coaxial cables, such as DS3 (Type 2 and 4 Ports). These criteria also apply to broadband communications equipment ports intended to interface with paired-conductors originating from coaxial distribution cable.

Broadband communications equipment intended to be protected by a surge protector is classified as follows:

- External (Broadband) protector -- the protector is located between the center conductor and shield of the coaxial cable, externally to the input of the EUT.
- Internal (Power-path) protector -- the protector is located internally to the EUT, usually along the power path.

Broadband communications equipment intended to be located at the customer premises may employ either external or internal protectors. The criteria applicable to broadband communications equipment employing an external protector are based on the let-through characteristics of a protector meeting the generic criteria of GR-2908-CORE, *Generic Requirements for Surge Protectors on Coaxial Lines at Customers Premises*.<sup>[47]</sup>

---

**R4-66 [94]** The manufacturer of broadband communications equipment intended for application with an external protector **shall** indicate the need for an external protector. An external surge protective device specified by the manufacturer **shall not** permit transients of greater magnitude or duration than are permitted by GR-2908-CORE,<sup>[47]</sup> on which the criteria of this section are based.

---

Broadband communications equipment intended to be located in the OSP typically employs internal protectors, and is therefore subject to the full lightning and ac power fault environment that may be encountered on the coaxial cable plant. The lightning and ac power fault immunity criteria differ, depending on whether or not the equipment is intended for use with an external protector.

---

**R4-67 [95]** Equipment that does not require the use of an external protector **shall** comply with the criteria of Section 4.10.2 and Section 4.10.3.

**R4-68 [96]** Equipment that is designed to be protected with an external protector **shall** comply with the criteria of Section 4.10.4.

---

Protection of some broadband communication equipment may rely on additional protective devices employed in the network. Such equipment may be tested in a system configuration that would include all the necessary protective devices. For example, such system configuration under test may consist of tap, fusing element, drop cable, surge protectors and network interface unit.

---

**CR4-69 [97]** Equipment tested in a system configuration **shall** comply with the criteria of Section 4.10.2 and Section 4.10.3. The manufacturer of such broadband communication systems **shall** indicate all devices needed to achieve protection.

---

#### 4.10.1 Number of Samples To Be Tested

Three (3) ports of the EUT in each applicable operating state shall be tested for the first-level tests described in [Section 4.10](#). For all other tests such as second-level tests and short-circuit tests, a Type Test shall be performed (see [Appendix D](#) for a definition of the Type Test).

For the first-level tests, the following guidelines apply:

- If the EUT has a single coaxial port, a total of three (3) coaxial ports shall be tested on three (3) different samples.
- If the EUT has two functionally and schematically identical coaxial ports, two ports on the same sample and one port on another sample shall be tested.
- If the EUT has three (3) or more functionally and schematically identical coaxial ports, three (3) random ports on the same EUT shall be tested.

Ports that are functionally and schematically identical and have similar design and layout rules (traces widths) are considered equivalent. Ports that are not schematically the same or utilize different design or layout rules that could reasonably affect the outcome of tests are considered different and must each be tested separately.

#### 4.10.2 Short-Circuit Tests

Short-circuit tests are intended to establish that broadband communications equipment containing an internal protector will not be damaged, or become a fire, fragmentation, or electrical safety hazard if the internal protector becomes short-circuited. The tests are conducted with the EUT powered and operating as in service, with the internal protector replaced with a short-circuit (no greater than 1 $\Omega$ ).

---

**R4-70 [99]** The EUT **shall not** be damaged and **shall not** become a fire, fragmentation, or electrical safety hazard as a result of a short circuit replacing the internal protector for 30 minutes. Cheesecloth is to be applied as described in [Section 4.6.4](#) as the fire hazard indicator.

---

#### 4.10.3 Broadband Communications Equipment Intended for Use Without External Protectors

The criteria of this section apply to an EUT that is intended for use without an external protector. If an internal protector is intended to be applied within the EUT, it is to be in place during the tests.

---

**R4-71 [100]** Broadband communications equipment that is intended to contain an internal protector **shall** be tested with the internal protector in place.

**R4-72 [101]** If the EUT uses an internal protector, the protector **shall** be easily accessible to craft personnel for examination and replacement.

**CR4-73 [102]** If the EUT uses an internal protector and has output ports intended to provide power or signal to customer-owned cable or equipment, the voltage measured at the output ports of the EUT **shall** be less than 1000 V during first- and second-level lightning surge tests or less than 600 V during first- and second-level power fault tests.

#### 4.10.3.1 First-Level Lightning and Power Fault Tests

The test surges are to be applied between the center conductor and the shield at all coaxial ports. The test leads used to connect the surge generator to the EUT shall not significantly affect the voltage and current waveform parameters. The EUT should be powered during lightning surge tests and, if possible, during ac power fault tests during the tests. The tests shall be done with all combinations of coaxial ports of the EUT not under stress short-circuited and open-circuited. The tests shall be performed in both power-passing and power-blocking configuration of the port, if applicable.

**R4-74 [103]** Upon the application of lightning surge and power fault tests as shown in [Table 4-21](#) and [Table 4-22](#), respectively, the EUT **shall not** be damaged and **shall** continue to operate properly.

**Table 4-21** First-Level Lightning Surge Test for Equipment Intended for Use Without an External Protector

Surge Test	Minimum Open-Circuit Peak Voltage	Minimum Short-Circuit Peak Current	Maximum Rise/Minimum Decay Time for Voltage and Current <sup>1</sup>	Repetitions, Each Polarity
1	± 1000 V	100 A	10/1000 μs	25
2	± 2000 V (see Note 2)	1000 A	10/250 μs	5

Notes to [Table 4-21](#):

1. Double exponential waveshape as defined in Appendix A.
2. The test should be performed at the indicated voltage and repeated at a reduced open-circuit voltage just below the operating threshold of the voltage-limiting device of the internal protector.

**Table 4-22** First-Level AC Power Fault Test for Equipment Intended for Use Without an External Protector

Test	Voltage (see Notes 1 and 2)	Current (see Notes 1 and 3)	Duration	Repetitions
1	600 V <sub>rms</sub>	40 A <sub>rms</sub>	1 second	1
2	600 V <sub>rms</sub>	10 A <sub>rms</sub>	1 second	5
3	600 V <sub>rms</sub>	1 A <sub>rms</sub>	1 second	60
4	600 V <sub>rms</sub>	0.5 A <sub>rms</sub>	30 seconds	1

Notes to *Table 4-22*:

1. All sources are 50 or 60 Hz sinusoidal.
2. For an EUT containing an internal protector, the test should be performed at the indicated voltage and repeated at a reduced open-circuit voltage just below the operating threshold of the voltage-limiting device of the internal protector.
3. For an EUT containing a current-limiting device, the test should be performed at the indicated available current and voltage and repeated at a reduced voltage and current just below the operating threshold of the internal protector and current-limiting device.

#### 4.10.3.2 Second-Level Lightning and Power Fault Tests

The test surges are to be applied between the center conductor and the shield at all coaxial ports. The test leads used to connect the surge generator to the EUT shall not significantly affect the voltage and current waveform parameters. The EUT should be powered during lightning surge tests and, if possible, during ac power fault tests during the tests. The tests shall be done with all combinations of coaxial ports of the EUT not under stress short-circuited and open-circuited. The tests shall be performed in both power-passing and power-blocking configuration of the port, if applicable. Cheesecloth is to be applied as described in [Section 4.6.4](#) as the fire hazard indicator.

---

**R4-75 [104]** Upon the application of the second-level surge tests as shown in [Table 4-23](#) and [Table 4-24](#), the EUT **shall not** become a fire, fragmentation, or electrical safety hazard.

---

**Table 4-23** Second-Level Lightning Surge Test for Equipment Intended for Use Without an External Protector

Surge Test	Minimum Open-Circuit Peak Voltage	Minimum Short-Circuit Peak Current	Maximum Rise/Minimum Decay Time for Voltage and Current <sup>1</sup>	Repetitions, Each Polarity
1	± 4000 V (see Note 2)	2000 A	10/250 μs	1

Notes to *Table 4-23*:

1. Double exponential waveshape as defined in Appendix A.
2. For an EUT containing an internal protector, the test should be performed at the indicated voltage and repeated at a reduced open-circuit voltage just below the operating threshold of the voltage-limiting device of the internal protector.

The second-level power fault tests are intended to ensure that the EUT can conduct safely currents that may result from accidental contact of the coaxial line with a power line in the OSP. Currently, characteristics of the fusing element in the coaxial broadband network have not been standardized. In the absence of a standardized fusing element, the second-level power fault criteria test the EUT in a “system” configuration. This system configuration consists of the EUT, coaxial cable or coaxial drop cable and the apparatus containing the fusing element (e.g., fuse cable, tap).

---

**R4-76 [105]** The ac power fault test **shall** be performed on equipment intended for use at customer premises, COs, or headend. The ac power fault test **shall** be performed on an assembly of EUT, coaxial cable, or coaxial or paired-conductor drop cable and the apparatus containing the fusing element (e.g., fuse cable, tap). Upon the application of the second-level ac power fault tests as shown in *Table 4-24*, the EUT **shall not** become a fire, fragmentation, or electrical safety hazard.

**O4-77 [106]** The ac power fault test **should** be performed on equipment intended for use at the OSP. The ac power fault test **should** be performed on an assembly of EUT, coaxial cable, or coaxial or paired-conductor drop cable and the apparatus containing the fusing element (e.g., fuse cable, tap). Upon the application of the second-level ac power fault tests as shown in *Table 4-24*, the EUT **should not** become a fire, fragmentation, or electrical safety hazard.

**R4-78 [107]** The manufacturer of broadband communication equipment **shall** indicate in equipment documentation the type of fusing element.

---

**Table 4-24** Second-Level AC Power Fault Test for Equipment Intended for Use Without an External Protector

Test	Voltage <sup>1</sup>	Current <sup>1</sup>	Duration	Repetitions
1	1000 V <sub>rms</sub>	5 A <sub>rms</sub>	15 minutes	1
2	1000 V <sub>rms</sub>	15 A <sub>rms</sub>	15 minutes	1
3	1000 V <sub>rms</sub>	30 A <sub>rms</sub> (See Note 2)	15 minutes	1
4	1000 V <sub>rms</sub>	60 A <sub>rms</sub>	15 minutes	1
5	1000 V <sub>rms</sub>	120 A <sub>rms</sub>	15 minutes	1
6	1000 V <sub>rms</sub>	350 A <sub>rms</sub>	3 minutes	1

Notes to *Table 4-24*:

1. All sources are 50 or 60 Hz sinusoidal.
2. For an EUT containing a current-limiting device, the tests are to be performed at the indicated available voltage and current and repeated at reduced voltage and current just below the operating threshold of the internal protector and current-limiting device.

#### 4.10.4 Broadband Communications Equipment Intended for Use With an External Protector

The criteria of this section apply to an EUT that is intended for use with an external protector. It is assumed that the external protector employs the generic characteristics of GR-2908-CORE. An EUT that complies with the criteria of [Section 4.10.3](#) is considered to be compliant with the criteria of [Section 4.10.4](#).

##### 4.10.4.1 First-Level Lightning and Power Fault Tests

The test surges are to be applied between the center conductor and the shield at all coaxial ports. The test leads used to connect the surge generator to the EUT shall not significantly affect the voltage and current waveform parameters. The EUT should be powered during lightning surge tests and, if possible, during ac power fault tests. The tests shall be done with all combinations of coaxial ports of the EUT not under stress short-circuited and open-circuited. The tests shall be performed in both power-passing and power-blocking configuration of the port, if applicable.

---

**R4-79 [108]** Upon the application of lightning surge and power fault tests as shown in [Table 4-25](#) and [Table 4-26](#) respectively, the EUT **shall not** be damaged and **shall** continue to operate properly.

---

**Table 4-25** First-Level Lightning Surge Test for Equipment Intended for Use With an External Protector

Surge Test	Minimum Open-Circuit Peak Voltage	Minimum Short-Circuit Peak Current	Maximum Rise/Minimum Decay Time for Voltage and Current <sup>1</sup>	Repetitions, Each Polarity
1	± 1000 V (see Notes 2 and 4)	100A	10/1000 μs	25
2	± 2000 V (see Notes 3 and 4)	1000A	10/250 μs	5

Notes to *Table 4-25*:

1. Double exponential waveshape as defined in Appendix A.
2. External protector is not used for surge test 1.
3. External protector should be installed between the surge generator and the test port of the equipment for surge test 2.
4. For equipment containing a secondary protector with a voltage-limiting device, the test is to be performed at the indicated voltage and repeated at a reduced open-circuit voltage just below the operating threshold of the voltage-limiting device of the secondary protector.

**Table 4-26** First-Level AC Power Fault Test for Equipment Intended for Use with an External Protector

Test	Voltage <sup>1</sup>	Current <sup>1</sup>	Duration	Repetitions
1	400 Vrms (see Notes 2 and 3)	0.5 A <sub>rms</sub>	30 second	1
2	400 Vrms (see Notes 2 and 3)	1 A <sub>rms</sub>	1 second	1

Notes to *Table 4-26*:

1. All sources are 50 or 60 Hz sinusoidal.
2. External protector is not used.
3. For an EUT containing a secondary protector, voltage-limiting device, or current-limiting device, the test is to be performed at the indicated voltage and current and repeated at a reduced voltage or current just below the operating threshold of the secondary protector, voltage-limiting device or current-limiting device.

#### 4.10.4.2 Second-Level Lightning and Power Fault Tests

The test surges are to be applied between the center conductor and the shield at all coaxial ports. The test leads used to connect the surge generator to the EUT shall not significantly affect the voltage and current waveform parameters. The EUT

should be powered during lightning surge tests and, if possible, during ac power fault tests during the tests. The tests shall be done with all combinations of coaxial ports of the EUT not under stress short-circuited and open-circuited. The tests shall be performed in both power-passing and power-blocking configuration of the port, if applicable. Cheesecloth is to be applied as described in Section 4.6.4 as the fire hazard indicator.

**R4-80 [109]** Upon the application of the second-level surge tests as shown in Table 4-27, the EUT **shall not** become a fire, fragmentation, or electrical safety hazard.

**Table 4-27** Second-Level Lightning Surge Test for Equipment Intended for Use With an External Protector

Surge Test	Minimum Open-Circuit Peak Voltage	Minimum Short-Circuit Peak Current	Maximum Rise/Minimum Decay Time for Voltage and Current <sup>1</sup>	Repetitions, Each Polarity
1	± 4000 V (see Notes 2 and 3)	2000A	10/250 μs	1

Notes to Table 4-27:

1. Double exponential waveshape as defined in Appendix A.
2. External protector is used for all tests.
3. For equipment containing a secondary protector with a voltage-limiting device, the test is to be performed at the indicated voltage and repeated at a reduced open-circuit voltage just below the operating threshold of the voltage-limiting device of the secondary protector.

The second-level power fault tests are intended to ensure that the EUT can safely conduct currents that may result from accidental contact of the coaxial line with a power line in the OSP. Currently, characteristics of the fusing element in the coaxial broadband network have not been standardized. In the absence of a standardized fusing element, the second-level power fault criteria test the EUT in a “system” configuration. This system configuration consists of the EUT, coaxial cable, or coaxial drop cable and the apparatus containing the fusing element (e.g., fuse cable, tap).

**R4-81 [110]** The ac power fault test **shall** be performed on equipment intended for use at customer premises, COs, or headend. The ac power fault test **shall** be performed on an assembly of EUT, coaxial cable or coaxial or paired-conductor drop cable and the apparatus containing the fusing element (e.g., fuse cable, tap). Upon the application of the second-level ac power fault tests as shown in Table 4-28, the EUT **shall not** become a fire, fragmentation, or electrical safety hazard.

**O4-82 [111]** The ac power fault test **should** be performed on equipment intended for use at the OSP. The ac power fault test **should** be performed on an assembly of EUT, coaxial cable, or coaxial or paired-conductor drop cable and the apparatus



containing the fusing element (e.g., fuse cable, tap). Upon the application of the second-level ac power fault tests as shown in [Table 4-28](#), the EUT **should not** become a fire, fragmentation, or electrical safety hazard.

**R4-83 [112]** The manufacturer of broadband communication equipment **shall** indicate in equipment documentation the type of fusing element.

**Table 4-28** Second-Level AC Power Fault Test for Equipment Intended for Use With an External Protector

Test	Voltage <sup>1,2</sup>	Current <sup>1,2</sup>	Duration	Repetitions
1	400 V <sub>rms</sub>	5 A <sub>rms</sub>	15 minutes	1
2	400 V <sub>rms</sub>	15 A <sub>rms</sub>	15 minutes	1
3	400 V <sub>rms</sub>	30 A <sub>rms</sub> (see Note 3)	15 minutes	1
4	400 V <sub>rms</sub>	60 A <sub>rms</sub>	15 minutes	1
5	400 V <sub>rms</sub>	120 A <sub>rms</sub>	15 minutes	1
6	400 V <sub>rms</sub>	350 A <sub>rms</sub>	3 minutes	1

Notes to [Table 4-28](#):

1. All sources are 50 or 60 Hz sinusoidal.
2. External protector is not used for all tests.
3. For an EUT containing a secondary protector, voltage-limiting device or current-limiting device, the test is to be performed at the indicated voltage and repeated at a reduced voltage or current just below the operating threshold of the secondary protector, voltage-limiting device or current-limiting device.

#### 4.10.5 First-Level Intra-Building Surge Tests

These tests apply to intra-building equipment coaxial ports. This test applies to grounded and ungrounded coaxial ports. However, if the coaxial port is not tested to the objective of this section and the coaxial cable shield is not grounded at both ends, then the coaxial port shall meet the requirements of [Section 4.6.9.1](#). Otherwise, the manufacturer’s documentation shall state that both ends of the shield must be grounded.

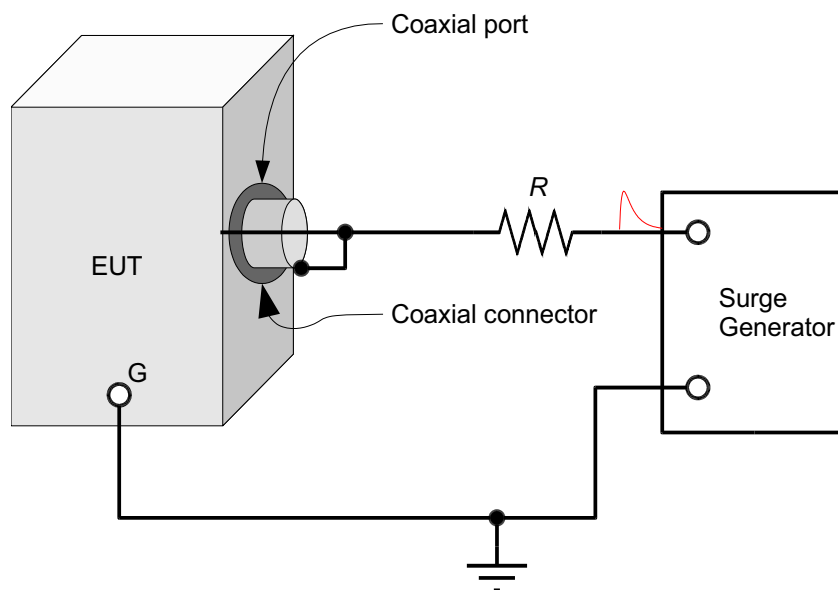
**O4-84 [207]** This objective will become a requirement effective January 1, 2008. Upon the application of the first-level surges shown in [Figure 4-19](#), the EUT (e.g, the surged coaxial ports) including the host system **shall not** be damaged and **shall** continue to operate properly as described in [Section 4.6.1](#). These lightning surge tests **shall** be performed with the EUT installed in an operating system performing its intended function. The open-circuit voltage for the test **shall** be 1500 V and the short-circuit current **shall** be limited by an external non-inductive resistor of 3 Ω. A 1.2/50-μs open-circuit voltage and 8/20-μs short-circuit current combination-wave generator with a 2-ohm internal impedance **shall** be used (i.e., the available short-circuit

current from the generator will be 300 A limited by the 2 Ω internal impedance of the generator and the 3 Ω external resistor).

**R4-85 [208]** Equipment **shall** contain the following, or substantially similar, warning in the equipment installation documentation.

**WARNING:** The intra-building port(s) of the equipment or subassembly is suitable for connection to intrabuilding or unexposed wiring or cabling only. The intra-building port(s) of the equipment or subassembly **MUST NOT** be metallically connected to interfaces which connect to the OSP or its wiring. These interfaces are designed for use as intra-building interfaces only (Type 2 or Type 4 ports as described in GR-1089-CORE, Issue 4) and require isolation from the exposed OSP cabling. The addition of Primary Protectors is not sufficient protection in order to connect these interfaces metallically to OSP wiring.

**Figure 4-19** Test Circuit for Coaxial Cable Ports Providing a Connection Means for the Shielded Cable



#### 4.10.6 Additional Criteria for Equipment Intended for the OSP

The following tests are intended to establish the ability of the coaxial cable shield-to-equipment connections to safely carry currents that may be imposed on the coaxial cable shield during commercial ac power faults and lightning events.

**R4-86 [113]** Upon the application of the power fault test described in the following paragraph, the EUT **shall not** be damaged and **shall** continue to operate properly.

The test shall be performed on all pair-wise combinations of all shields of coaxial ports. The shields of the coaxial cable for a coaxial port shall be connected to terminals of a 60-Hz source using wires equivalent to a No. 4 AWG copper conductor. A current of 1000 A<sub>rms</sub> shall be applied for 20 seconds.

If the EUT provides a grounding post, the test shall also be performed on all combinations of shields of coaxial ports and the post. In this case, the shield of the coaxial cable for a coaxial port and the grounding post shall be connected to terminals of a 60-Hz source using wires equivalent to a No. 4 AWG copper conductor. A current of 1000 A<sub>rms</sub> shall be applied for 20 seconds.

---

**R4-87 [114]** Upon the application of the surge test described in the following paragraph, the EUT **shall not** be damaged and **shall** continue to operate properly.

---

The test shall be performed on all pair-wise combinations of all shields of coaxial ports. The shields of the coaxial cable for a coaxial port shall be connected to terminals of a surge generator and a 20-kA, 8/20- $\mu$ s current shall be applied.

If the EUT provides a grounding post, the test shall also be performed on all combinations of shields of coaxial ports and the post. The shield of the coaxial cable for a coaxial port and the grounding post shall be connected to terminals of a surge generator and a 20-kA, 8/20- $\mu$ s current shall be applied.

#### 4.11 Lightning Criteria for Equipment Interfacing With Antennas

The criteria in this section apply to equipment that has lightning protection (e.g., surge protective devices, stub matching) installed external to the antenna port (see Type 6 Port in [Appendix B](#)). The EUT is to be operating and performing its design-intended functions during the application of the surges shown in [Table 4-29](#). The leads of the antenna ports associated with the EUT, as well as other connections to the EUT (such as control leads), are to be terminated as in service, except the port under test. The test surges are to be applied between the center conductor and the shield at the antenna port under test.

If the EUT has three (3) or more antenna ports, a minimum of three (3) antenna ports of EUT are to be tested. Otherwise, all antenna ports are to be tested.

---

**R4-88 [209]** Upon the application of the first-level surge shown in [Table 4-29](#), the EUT **shall not** be damaged and **shall** continue to operate properly. The manufacturer **shall** indicate in the equipment documentation that a lightning protection(s) **shall** be used that does not permit transients of greater magnitude or duration than the transient specified in [Table 4-29](#).

---

**Table 4-29** First-Level Lightning Surge (Antenna Port)

Surge	Minimum Peak Voltage (Volts) <sup>3,5</sup>	Nominal Voltage Rise/ Decay Time <sup>2</sup> ( $\mu$ s)	Minimum Peak Current per Conductor (Amperes) <sup>4</sup>	Nominal Current Rise/ Decay Time <sup>2</sup> ( $\mu$ s)	Repetitions, Each Polarity <sup>1</sup>
1	$\pm 600$ V	1.2/50	300 A	8/20	5

Notes to *Table 4-29*:

1. The external lightning protection is not used during the testing.
2. The generator is defined in IEEE C62.41.2.<sup>[30]</sup>
3. Minimum peak open-circuit voltage available from the test generator.
4. Minimum peak short-circuit current available from the test generator.
5. For an EUT containing a secondary voltage-limiting lightning protection device on the antenna port, the test is to be performed at the indicated voltage and repeated at a reduced voltage just below the operating threshold of the secondary protection device.

## 4.12 Lightning Criteria for Equipment Interfacing With AC Power Port(s)

The lightning criteria for equipment port(s) that interfaces with commercial AC power, shall apply as follows:

- The criteria in [Section 4.12.1](#) apply to equipment with AC power ports that are intended for deployments where an external Surge Protective Device (SPD) is utilized at the ac power service equipment (see definition in NEC<sup>[49]</sup>). These criteria also apply to equipment connected to receptacles inside buildings such as computers, terminal adapters, rectifiers, etc.
- The criteria in [Section 4.12.2](#) apply to equipment with AC power ports that are intended for deployments where an external Surge Protective Device (SPD) is not utilized, and are also located in close proximity to the ac power service equipment or connected to major feeders. The criteria generally do not apply to equipment connected to receptacles inside buildings such as computers, terminal adapters, rectifiers, etc.

---

**R4-89 [210]** The manufacturer **shall** specify in the documentation whether an external Surge Protective Device (SPD) is intended to be used at the ac input of the network equipment.

---

### 4.12.1 Equipment Used in Facilities With an External SPD

The EUT is to be operating and performing its design-intended functions during the application of the surges shown in [Table 4-30](#). The leads of the telecommunications ports associated with the EUT as well as other connections to the EUT (such as control leads) are to be terminated as in service.

The EUT is to be powered during the application of the surges of [Table 4-31](#). Cheesecloth is to be applied as described in [Section 4.6.4](#) as the fire hazard indicator.

A minimum of three (3) samples of EUT shall be tested for ac power ports for the first-level test specified in [Table 4-30](#). A Type Test shall be performed for ac power ports for the second-level test specified in [Table 4-31](#). The surges shown in [Table 4-30](#) and [Table 4-31](#) are to be applied between

- Each phase conductor separately and the neutral conductor
- Each phase conductor separately and the green-wire ground
- The neutral conductor and green-wire ground.

**R4-90 [32]** Upon the application of the first-level surge shown in [Table 4-30](#), the EUT **shall not** be damaged and **shall** continue to operate properly as described in [Section 4.6.1](#).

**R4-91 [33]** As a result of the application of the second-level surge shown in [Table 4-31](#), the EUT **shall not** become a fire, fragmentation, or electrical safety hazard as described in [Section 4.6.1](#).

**Table 4-30** First-Level Lightning Surge (AC Power Port)

Surge	Nominal Peak Voltage <sup>2</sup> (Volts) <sup>4</sup>	Nominal Voltage Rise/ Decay Time <sup>1</sup> ( $\mu$ s)	Nominal Peak Current per Conductor <sup>3</sup> (Amperes)	Nominal Current Rise/ Decay Time <sup>1</sup> ( $\mu$ s)	Repetitions, Each Polarity
1	$\pm 2000$	1.2/50	1000	8/20	4

**Table 4-31** Second-Level Lightning Surge (AC Power Port)

Surge	Nominal Peak Voltage <sup>2</sup> (Volts) <sup>4</sup>	Nominal Voltage Rise/ Decay Time <sup>1</sup> ( $\mu$ s)	Nominal Peak Current per Conductor <sup>3</sup> (Amperes)	Nominal Current Rise/ Decay Time <sup>1</sup> ( $\mu$ s)	Repetitions, Each Polarity
1	$\pm 6000$	1.2/50	3000	8/20	1

Notes to [Table 4-30](#) and [Table 4-31](#):

1. The combination wave as defined in IEEE C62.41.2<sup>[30]</sup>.
2. Minimum peak open-circuit voltage available from the test generator.
3. Minimum peak short-circuit current available from the test generator.

4. For an EUT containing voltage-limiting surge protective devices on the ac power port, the tests are to be performed at the indicated voltage and repeated at a reduced voltage just below the operating threshold of the surge protective device. The test need not be repeated at the reduced voltage for the second-level conditions shown in [Table 4-31](#) if conformance has been demonstrated by the performance of the first-level tests of [Table 4-30](#).

#### 4.12.2 Equipment Used in Facilities Without an External SPD

The EUT is to be operating and performing its design-intended functions during the application of the surges shown in [Table 4-32](#). The leads of the telecommunications ports associated with the EUT as well as other connections to the EUT (such as control leads) are to be terminated as in service.

A minimum of three (3) samples of EUT shall be tested for ac power ports for the first-level test specified in [Table 4-32](#). The surges shown in [Table 4-32](#) are to be applied between

- Each phase conductor separately and the neutral conductor
- Each phase conductor separately and ac equipment grounding conductor (green-wire ground)
- The neutral conductor and the ac equipment grounding conductor (green-wire ground)

**R4-92 [211]** Upon the application of the first-level surge shown in [Table 4-32](#), the EUT **shall not** be damaged and **shall** continue to operate properly as described in [Section 4.6.1](#).

**Table 4-32** First-Level Lightning Surge (AC Power Port)

Surge	Nominal Peak Voltage <sup>2</sup> (Volts) <sup>4</sup>	Nominal Voltage Rise/ Decay Time <sup>1</sup> ( $\mu$ s)	Nominal Peak Current per Conductor <sup>3</sup> (Amperes)	Nominal Current Rise/ Decay Time <sup>1</sup> ( $\mu$ s)	Repetitions, Each Polarity
1	$\pm 6000$	1.2/50	3000	8/20	4

Notes to [Table 4-32](#):

1. The wave generator as defined in IEEE C62.41.2.<sup>[30]</sup>
2. Minimum peak open-circuit voltage available from the test generator.
3. Minimum peak short-circuit current available from the test generator.
4. For an EUT containing voltage-limiting surge protective devices on the ac power port, the tests are to be performed at the indicated voltage and repeated at a reduced voltage just below the operating threshold of the surge protective device.

## 4.13 Lightning Criteria for Equipment Interfacing With DC Power Port(s)

This section applies only to DC powering port(s) on equipment that is intended to be located in OSP facilities such as EECs. In addition, this section does not apply to equipment with DC-C configuration in accordance with [Section 9.8.3](#). This section will become effective January 1, 2008. This grace period should provide ample time for equipment manufacturers to evaluate their equipment for the criteria specified in this section.

Where equipment is intended for deployments with a specific rectifier and in a defined dc power configuration, the equipment can be tested in accordance with the first-level criteria of [Section 4.12.1](#) or [Section 4.12.2](#), as applicable. The test surges are applied to the ac input of the rectifier and the equipment is connected to the dc output of the rectifier.

### 4.13.1 Tests Directly on DC Power Port

The EUT is to be operating and performing its design-intended functions during the application of the surges. The leads of the telecommunications ports associated with the EUT as well as other connections to the EUT (such as control leads) are to be terminated as in service.

A minimum of one sample of EUT shall be tested for dc power ports. The surges are to be applied simultaneously between

- The supply lead and the ground
- The return lead and the ground.

[Figure 4-20](#) shows a test circuit for performing this test.

---

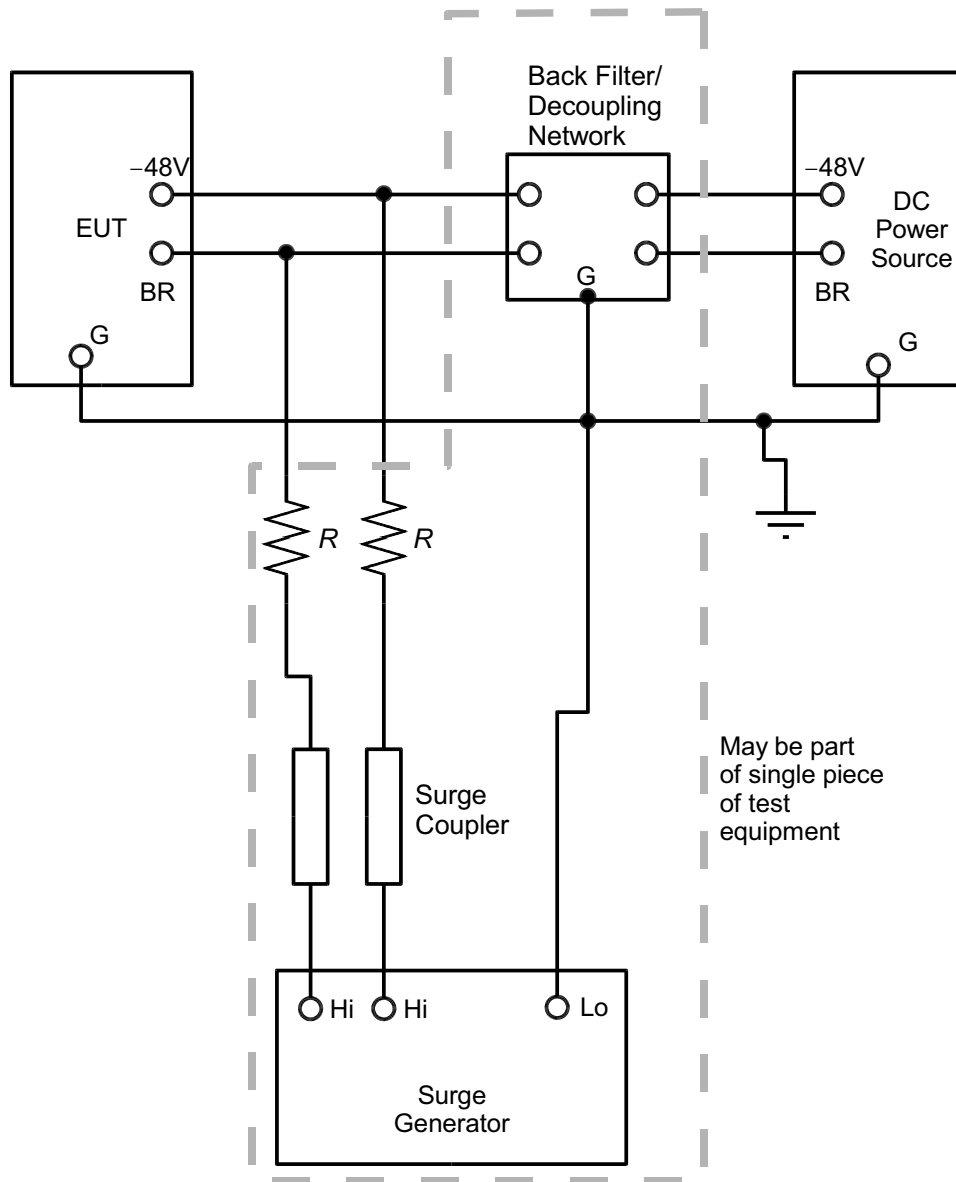
**CO4-93 [212]** This objective will become effective January 1, 2008. The EUT should not be damaged and should continue to operate properly as described in [Section 4.6.1](#) upon the application of the following first-level surge on the dc power port:

- Five (5) repetitions for each polarity of the 0.5 $\mu$ s-100 kHz ring wave surge with a peak voltage of 0.5 kV, and a current level of 41.7 amperes per conductor (i.e., each output of the generator has an effective impedance of 12 ohms in [Figure 4-20](#)).<sup>[30]</sup>

---

**NOTE:** The combination wave per IEEE C62.41.2<sup>[30]</sup> may be used instead of the ring wave surge. The peak surge shall be 500 V and shall be limited by the inclusion of a series 10-ohm non-inductive resistor placed externally on each output of the surge generator as shown in [Figure 4-20](#).

Figure 4-20 Test Circuit for Lightning Test on DC Power Port





## 5 Steady-State Power Induction

### 5.1 Overview

Network equipment that interfaces directly with metallic OSP facilities may be subject to the interfering effects of steady-state voltages induced from nearby power lines. Through electromagnetic coupling, currents on such ac power lines during normal operation may induce long-term, steady-state voltages and currents into nearby telecommunications OSP facilities. The induced voltages are longitudinal (common mode) in nature.

Power induction may interfere with transmission or affect signaling and supervisory functions. The 60- and 180-Hz components of the induced voltage spectrum are significant from the standpoint of interference with signaling and supervisory functions. From the standpoint of interference with voice-frequency transmission, the odd harmonics of 60 Hz are of greatest importance because they occur within the voice band and can produce audible noise. The even harmonics are generated in an unbalanced power system, but their levels are significantly lower than those of the odd harmonics.

This section contains test methods and generic criteria for immunity of network equipment to steady-state power induction (power lines operating normally). Induced voltages resulting from abnormal power fault conditions are discussed in [Section 4](#).

For paired-conductor cables, the induced voltage source may be considered to be concentrated at a point in the loop that is closer to the subscriber end than the Central Office (CO) end. This is in agreement with the 1980 Bell System Noise Survey of the Loop Plant. However, the center-of-exposure concept gives different results for short loops (less than 20 kilofeet [kft]) than for long loops (greater than 20 kft). For short paired-conductor loops, the center-of-exposure ranges from 53% to 68% of the distance from the CO to the subscriber end. For long paired-conductor loops, the center-of-exposure ranges from 75% to 85% of the distance from the CO to the subscriber end.

The criteria of this section apply to network equipment port types 1 and 3 as described in [Appendix B](#). If the EUT is to be used on long paired-conductor loops (greater than 20 kft), use [Section 5.2](#); if it is confined to short paired-conductor loops (less than 20 kft), use [Section 5.3](#); if it is to be used on trunks, use [Section 5.4](#). However, these criteria do not apply to equipment intended to be used only for paired-conductor loops less than 5 kft.

In addition, criteria included in [Section 5.5](#) applies to equipment intended for use in coaxial cables.

### 5.2 Longitudinal Induction Criteria for Long (> 20 kft) Loops

The longitudinal induction test circuit simulates a long subscriber loop under the influence of power induction. It consists of a two-port loop simulation network and an injection transformer for the application of the longitudinal test voltages (see [Figure 5-1](#)). The loop simulation network may be implemented either through the

use of 3-wire (tip, ring, ground) artificial cable sections and loading coils, actual telecommunications cable, or by comparable lumped element networks. For 4-wire circuits (two pairs of tip and ring), each pair of wires shall be subjected to steady-state power induction using the test circuit of [Figure 5-1](#).

The injection transformer should have a minimum of three closely coupled windings on a ferromagnetic core (a minimum of a 5-winding transformer would be required for testing 4-wire circuits). One example of a suitable transformer is a low-voltage multipair neutralizing transformer of the type used for the mitigation of power induction on telecommunications cables. The waveform of the applied test voltage should be a 60-Hz triangular wave with positive-going and negative-going excursions symmetrical about each peak.

For voiceband circuits, the loop simulation network may be realized through the use of 3-wire artificial cable sections and loading coils. Loading coils of 66 mH should be used separated by 6-kft cable sections. The loading coils should be separated by 3-kft cable sections from the CO end, the customer end and the injection transformer windings.

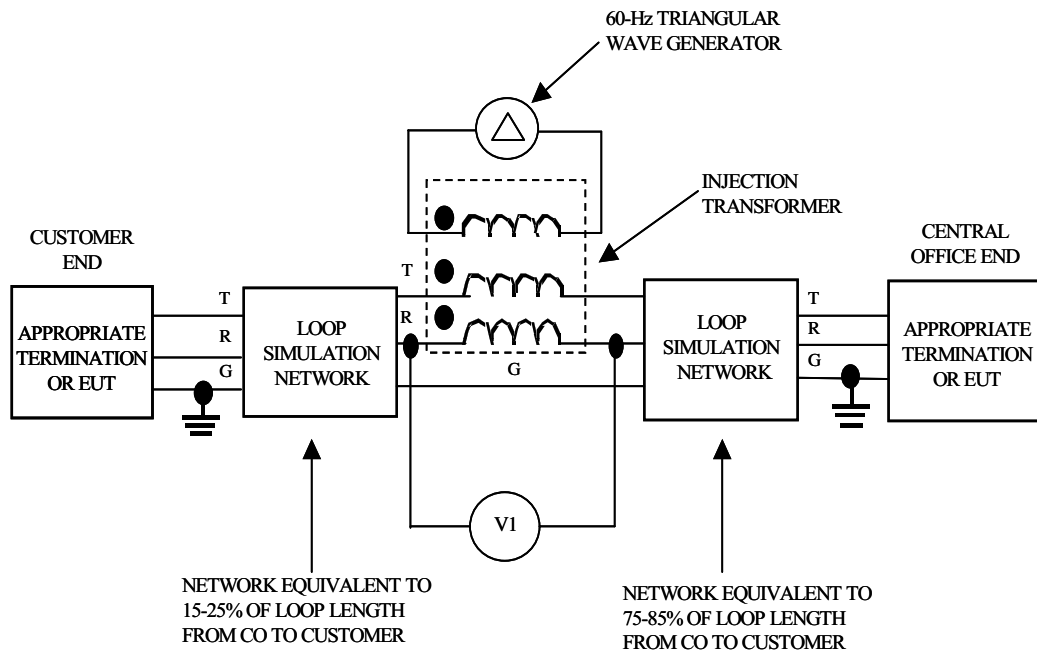
For digital systems operating on long (>20 kft) loops, the loop simulation network may be realized through an actual telecommunications cable. If commercially available, 3-wire (tip, ring, and ground) artificial cable sections may be used. The artificial cables should exhibit the transmission characteristics of the digital system throughout their operating frequency band.

### 5.2.1 Longitudinal Induction Test Circuit for Long (> 20 kft) Loops

[Table 5-1](#) contains the longitudinal induction test circuit criteria for network equipment intended to be applied in a long loop, when tested as shown in [Figure 5-1](#). The circuit of [Figure 5-1](#) should be designed and calibrated to exhibit the “required” and “conditional required” values of the parameters listed in [Table 5-1](#).

Equipment that functions properly in the presence of the required value of voltage and current can be expected to be immune to most induction environments. Equipment that functions properly in the presence of the conditional required values of voltage and current can be expected to be immune even in unusually severe induction environments. Such unusually severe environments may be encountered in rural areas where telecommunications lines have long exposure to electric power systems.

**Figure 5-1** Longitudinal Induction Test Circuit for Long (> 20 kft) Loops



**NOTES:**

Refer to Table 5-1 for termination conditions, circuit parameters, and required and conditional parameter values.

Refer to Appendix B for categorization of the EUT Port as applicable to the “Central Office End” (Port Type 1) and “Customer End” (Port Type 3).

The applied voltage may be monitored by a voltage meter (V1) across any spare winding of the injection transformer.

**Table 5-1** Longitudinal Induction Test Circuit Criteria for Long (> 20 kft) Loops

Termination Conditions	Parameter	Required Value	Conditional Required Value
1, 2, 3, 4	Applied voltage (triangular wave) across injection-transformer secondary winding (0 dBrn = 24.5 $\mu$ V across 600 ohms)	$\geq 126$ dBrn (50 V rms)	$\geq 130$ dBrn (80 V rms)
1	Induced current ( $I_{co}$ ) per pair	$\geq 21$ dBmA (11.2 mA rms)	$\geq 25$ dBmA (17.8 mA rms)
1	Induced voltage ( $V_{ss}$ )	126 dBrn (50 V rms)	130 dBrn (80 V rms)
2	Longitudinal voltage ( $V_{co}$ )	110 to 114 dBrn (7.5 to 12.5V rms)	114 to 118 dBrn (12 to 20 V rms)
3	Total short-circuit current ( $I_{cs}$ ) per pair	$\geq 40$ dBmA (100 mA rms)	$\geq 44$ dBmA (160 mA rms)
4	C-Message noise-to-ground at customer end	86 $\pm$ 1 dBrnC	90 $\pm$ 1 dBrnC
4	C-Message weighted metallic noise at customer end	10 to 12 dBrnC	14 to 16 dBrnC
Not Applicable	Applied Voltage ( $V_1$ )	$\geq 126$ dBrn (50 V rms)	$\geq 130$ dBrn (80 V rms)
Not Applicable	Voltage injection point (distance from CO end to customer end)	75% to 85%	75% to 85%
Not Applicable	Loop resistance for voice systems	1200 to 1500 $\Omega$	1200 to 1500 $\Omega$
Not Applicable	Insertion loss for voice systems (1000 Hz, between 600- or 900-ohm impedances)	4.5 to 8.5 dB	4.5 to 8.5 dB

*Notes to Table 5-1:*

1. A two-letter subscript is used to describe the induced currents and voltages. The first letter of the subscript shows the end at which the measurement was made: "c" for the CO end and "s" for customer (subscriber) end. The second letter of the subscript shows the termination condition at the other end: "o" for open circuit and "s" for short circuit. For example, the subscript "co" means that the measurement was made at the CO end (c) with open circuit at the customer end (o).

2. If the EUT is intended for a system that operates within a specific maximum loop length ( $L_{\max}$ ), but greater than 20 kft, the test circuit should be designed and calibrated to exhibit the following induced current ( $I_{co}'$ ) instead of the value depicted in **Table 5-1**:

$$I_{co}' \geq I_{co} \cdot \frac{L_{\max}}{82}$$

where  $L_{\max}$  is the maximum operating length of the system in kft and the induced current ( $I_{co}$ ) is the required or conditional value of **Table 5-1**.

3. A common-mode capacitance ( $C_g$ ) of 120 nF/km is used for designing the test circuit. However, this value may vary from 100 to 150 nF/km.
4. Termination Conditions (see **Figure 5-1**):
- Open circuit at customer end; tip and ring shorted to ground through 10 ohms at the CO end.
  - Open circuit at both ends.
  - At customer end: 250 ohms from tip to ground, 250 ohms from ring to ground. At the CO end: tip and ring shorted to ground through 10 ohms.
  - At customer end: open circuit. Measure noise-to-ground with a high-impedance Noise-Measuring Set (NMS); measure metallic noise with the NMS having a 600- to 900-ohm terminating impedance. At the CO end: well-balanced 600- to 900-ohm termination with grounded center tap (the longitudinal impedance of termination is not to exceed 200 ohms).

## 5.2.2 Calibration Procedure

The test circuit shown in **Figure 5-1** is to be calibrated to the characteristics indicated in **Table 5-1**. Calibration measurements are to be made using an NMS with either 3-kHz flat weighting or C-Message weighting, as appropriate. The input impedance of the NMS must be at least 100 kilohms from each input terminal to ground. A true rms meter may be used for calibrating the test circuit.

## 5.2.3 Test Procedures

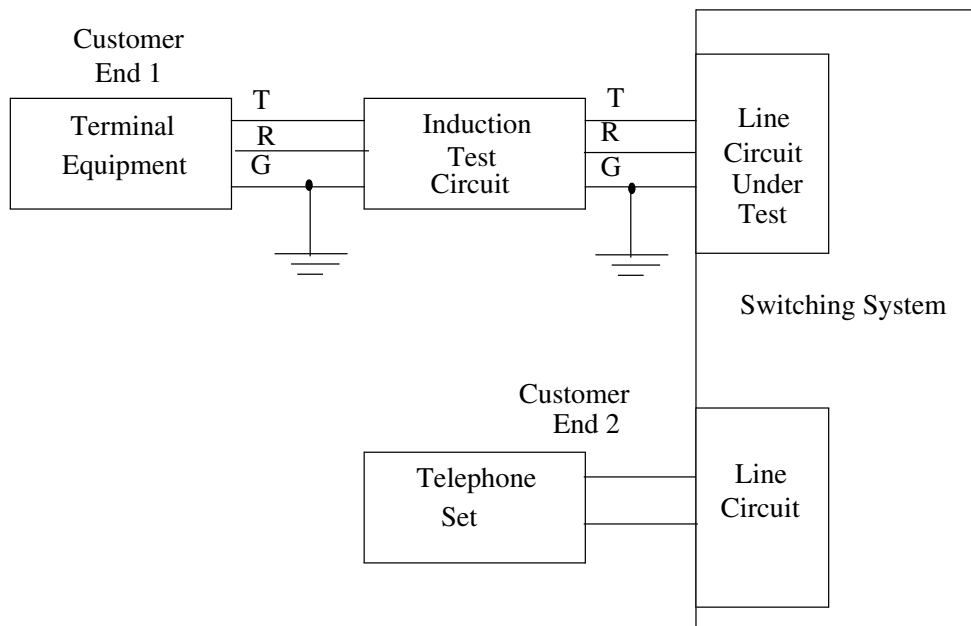
Based on the Port Type 1 or 3 under test, the EUT is placed in the test circuit at the appropriate location as described in **Appendix B**, either the CO end or the far end, and the other end is terminated by representative equipment necessary for the EUT to perform its design-intended functions. To simplify the discussion of the testing procedure, the testing of a CO switching system line circuit will be considered as an example. Similar procedures apply to other types of network equipment.

### 5.2.3.1 Test Procedure for a CO Switching System Line Circuit

After the test circuit of **Figure 5-1** has been calibrated, de-energize the voltage source and connect the CO end of the test circuit to the switching system line circuit to be tested (see **Figure 5-2**). At customer end 1, connect the appropriate terminal equipment (such as a telephone set or coin station). Connect a second piece of

appropriate terminal equipment (such as a telephone set) to customer end 2. Initiate a call from the end 1 terminal equipment to the telephone at end 2. Verify that all operational states (on-hook, off-hook, dialing, ringing, talk, call termination, etc.) are performing properly. Process a call in the reverse direction and again verify proper switching system operation.

**Figure 5-2** Line Circuit Test Arrangement



When it has been determined that normal call processing occurs without any “induced voltage” applied to the test circuit, the test generator output is to be increased until the “required” voltage (126 dB<sub>rn</sub>) is measured across a transformer secondary winding. Repeat the call processing procedure to verify proper operation in all operating states in the presence of simulated induction. In a similar manner, tests are to be performed while applying the “conditional required” level of longitudinal voltage indicated in [Table 5-1](#).

For testing noise performance, dial up a connection through the line circuit to the quiet termination of the switching system while applying the “required” voltage indicated in [Table 5-1](#) (see termination condition 4). Hold the connection with a holding circuit (internal to some noise-measuring sets) and disconnect the customer equipment used to dial the call. It is preferable that a mechanical holding circuit is used rather than an electronic holding circuit. Measure the C-Message weighted metallic noise at the customer end with a NMS having 600- or 900-ohm terminating impedance. In a similar manner, the test is to be performed while applying the “conditional required” level of voltage indicated in [Table 5-1](#).

## 5.2.4 Performance Criteria

All network equipment on long loops that may be influenced by power induction is to be tested for proper performance using the induction test circuit shown in [Figure 5-1](#). In general, performance criteria of the EUT are given in the applicable Telcordia Generic Requirements, national and international standards. EUT with different operating functions including transient functions shall be tested for each operating function. For example, all applicable operating functions of switching system line cards, including transient states (such as coin functions and test functions) are to be tested as described in [Section 5.2.3.1](#). A digital system (such as DDS) is to be tested for Bit Error Ratio (BER) as described in [Section 5.2.3](#).

Three units of the equipment are to be tested in each applicable operating function at both the “required” and “conditional required” test levels.

---

**R5-1** [42] The operating functions of the EUT **shall** perform properly when the EUT is connected to the test circuit shown in [Figure 5-1](#) that exhibits the “required” values listed in [Table 5-1](#).

**CR5-2** [43] It is a conditional requirement that the operating functions of the EUT perform properly when connected to the test circuit shown in [Figure 5-1](#) that exhibits the “conditional required” values listed in [Table 5-1](#).

---

“Failure” of an operational function at both “required” and “conditional required” levels is judged to occur when the desired operation malfunctions. For example, a digital system (such as DDS) is judged to “pass” when the measured BERs at both customer ends meet the requirement value of  $10^{-7}$  or less in the presence of longitudinal induction.

## 5.2.5 Noise Performance for Voiceband Circuits

All network equipment with voiceband circuits on long loops that may be influenced by metallic noise is to be tested for noise performance using the induction test circuit shown in [Figure 5-1](#).

Three units of the equipment are to be tested at both the “required” and “conditional required” test levels.

---

**R5-3** [44] For network equipment with voiceband circuits, the C-Message weighted metallic noise at the customer end **shall not** exceed 20 dBmC with the “required” value of voltage applied.

**CR5-4** [45] For network equipment with voiceband circuits, it is a conditional requirement that the C-Message weighted metallic noise at the customer end not exceed 20 dBmC with the “conditional required” value of voltage applied.

---

### 5.3 Longitudinal Induction Criteria for Short (< 20 kft) Loops

The longitudinal induction test circuit simulates a short subscriber loop under the influence of power induction. It consists of a two-port loop simulation network and an injection transformer for the application of the longitudinal test voltages (see [Figure 5-3](#)). The loop simulation network may be implemented either through the use of 3-wire (tip, ring, and ground) artificial cable sections, actual telecommunications cable, or by a comparable mixed element network. For 4-wire circuits (two pairs of tip and ring), each pair of wires shall be subjected to steady-state power induction using the test circuit of [Figure 5-3](#).

The injection transformer should have a minimum of three closely coupled windings contained on a ferromagnetic core (a minimum of a 5-winding transformer would be required for testing 4-wire circuits). The waveform of the applied test voltage should be a 60-Hz triangular wave with positive-going and negative-going excursions symmetrical about each peak.

Digital Subscriber Lines (DSLs), a technology that allows data services over paired-conductor cables, are designed to operate on nonloaded loops of less than 18 kft. Equipment associated with the DSL technology is to be tested with the longitudinal induction test circuit that simulates a short subscriber loop under the influence of power induction. Such DSL systems are Integrated Services Digital Network (ISDN), High Data Rate Digital Subscriber Line (HDSL), Single Line Digital Subscriber Line (SDSL) and Asymmetric Digital Subscriber Line (ADSL).

For digital systems (e.g., DSL) operating on short (<20 kft) loops, the loop simulation network may be realized through an actual telecommunications cable. Three-wire (tip, ring, and ground) artificial cable sections may be used if they are commercially available. The artificial cables should exhibit the transmission characteristics of the digital system throughout their operating frequency band. For digital systems serving loops exceeding 20 kft, the criteria of [Section 5.2](#) apply.

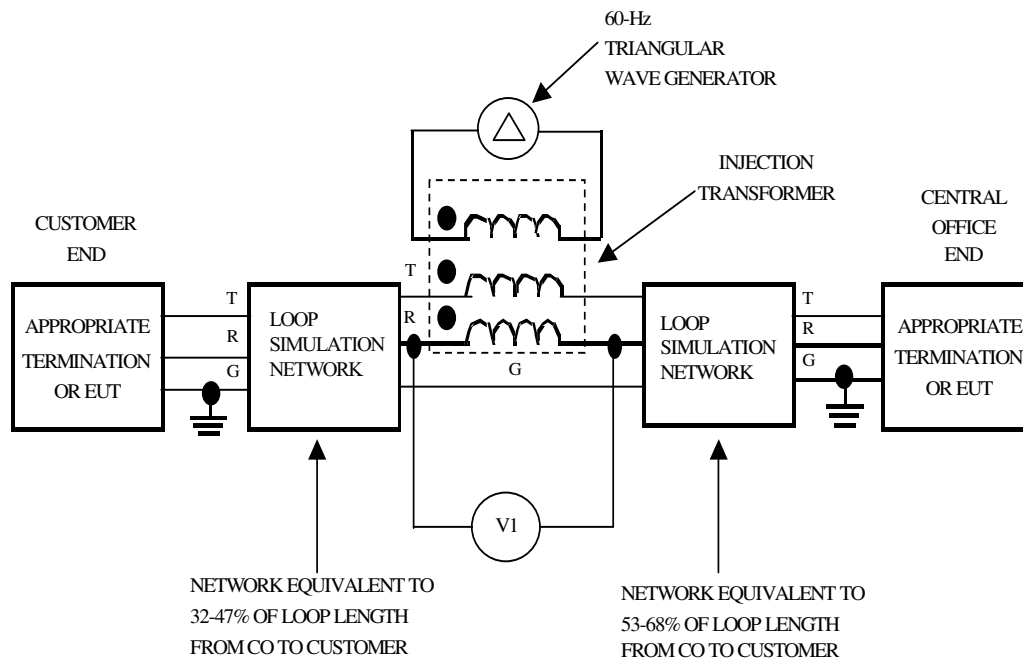
The Digital Loop Carrier (DLC) system consists of a Central Office Terminal (COT) located near the switching system and a Remote Terminal (RT) located near the customers to be served. An RT can serve the customers over a Carrier Serving Area (CSA) cable that is a nonloaded loop of less than 12 kft. In this section, the DLC services provided from the RT to the customer end over a CSA cable are tested with the longitudinal induction test circuit that simulates a short subscriber loop under the influence of power induction. For DLC serving loops that exceed CSA lengths, but are shorter than 20 kft, the criteria of this section apply. For DLC serving loops exceeding 20 kft, the criteria of [Section 5.2](#) apply.

#### 5.3.1 Longitudinal Induction Test Circuit for Short (< 20 kft) Loops

[Table 5-2](#) contains the longitudinal induction test circuit criteria for network equipment intended to be applied in a short loop when tested as shown in [Figure 5-3](#). The circuit shown in [Figure 5-3](#) should be designed and calibrated to exhibit the “required” values of the parameters listed in [Table 5-2](#). Equipment that functions properly in the presence of the required values of voltage and current can be expected to be immune even in the most severe induction environments.



**Figure 5-3** Longitudinal Induction Test Circuit for Short (< 20 kft) Loops



**NOTES:**

Refer to Table 5-2 for termination conditions, circuit parameters, and required parameter values.

Refer to Appendix B for categorization of the EUT Port as applicable to the "Central Office End" (Port Type 1) and "Customer End" (Port Type 3).

The applied voltage may be monitored by a voltage meter (V1) across any spare winding of the injection transformer.

**Table 5-2** Longitudinal Induction Test Circuit Criteria for Short (< 20 kft) Loops

Termination Conditions	Parameter	Required Value
1, 2, 3, 4	Applied voltage (triangular wave) across injection transformer secondary winding (0 dBrn equals 24.5 μV across 600 ohms)	≥126 dBrn (50 V rms)
1	Induced current ( $I_{co}$ ) per pair	≥ 11 dBmA (≥ 3.55 mA rms)
1	Induced voltage ( $V_{ss}$ )	126 dBrn (50 V rms)
2	Longitudinal voltage ( $V_{co}$ )	116 to 119.4 dBrn (16 to 23.5V rms)
3	Total short-circuit current ( $I_{cs}$ ) per pair	≥ 41 dBmA (≥ 112 mA rms)
4	C-Message noise-to-ground	86 ±1 dBrnC
4	C-Message weighted metallic noise	10 to 12 dBrnC
Not Applicable	Applied Voltage ( $V_1$ )	≥ 126 dBrn (50 V rms)
Not Applicable	Voltage injection point (distance from CO end to customer end)	53% to 68%
Not Applicable	Loop resistance for DSL	600 to 1300Ω
Not Applicable	Loop resistance for DLC (between RT and customer end)	600 to 820Ω
Not Applicable	80-kHz insertion loss for ISDN	22.5 to 48 dB
Not Applicable	1-kHz insertion loss for DLC	3 to 4.65 dB

*Notes to Table 5-2:*

1. A two-letter subscript is used to describe the induced currents and voltages. The first letter of the subscript shows the end at which the measurement was made: “c” for CO end and “s” for the customer (subscriber) end. The second letter of the subscript shows the termination condition at the other end: “o” for open circuit and “s” for short circuit. For example, the subscript “co” means that the measurement was made at the CO end (c) with open circuit at the customer end (o).
2. If the EUT is intended for a system that operates within a specific maximum loop length ( $L_{max}$ ), but less than 12 kft, the test circuit should be designed and calibrated to exhibit the following induced current ( $I_{co}'$ ) instead of the value depicted in Table 5-2:

$$I_{co}' \geq I_{co} \cdot \frac{L_{max}}{12}$$

where  $L_{max}$  is the maximum operating length of the system in kft and the induced current ( $I_{co}$ ) is the required or conditional value of Table 5-2.

3. A common-mode capacitance ( $C_g$ ) of 120 nF/km is used for designing the test circuit. However, this value may vary from 100 to 150 nF/km.
4. Termination Conditions (see [Figure 5-3](#)):
  - a. Open circuit at customer end; tip and ring shorted to ground through 10 ohms at the CO end.
  - b. Open circuit at both ends.
  - c. At customer end: 250 ohms from tip to ground, 250 ohms from ring to ground. At the CO end: tip and ring shorted to ground through 10 ohms.
  - d. At customer end: open circuit. Measure noise-to-ground with high-impedance NMS; measure metallic noise with NMS having 600- to 900-ohm terminating impedance. At the CO end: well-balanced 600- to 900-ohm termination with grounded center tap (longitudinal impedance of termination not to exceed 200 ohms).

### 5.3.2 Calibration Procedure

The test circuit shown in [Figure 5-3](#) is to be calibrated to exhibit the characteristics indicated in [Table 5-2](#). Calibration measurements are to be made using an NMS with either 3-kHz flat weighting or C-Message weighting, as appropriate. The input impedance of the NMS is to be at least 100 kilohms from each input terminal to ground. A true rms meter may be used for calibrating the test circuit.

### 5.3.3 Test Procedures

Based on the Port Type 1 or 3 under test, the EUT is placed in the test circuit at the appropriate location as described in [Appendix B](#), either the CO end or the far end, and the other end is terminated by representative equipment necessary for the EUT to perform its design-intended functions.

To simplify the discussion of the testing procedure, the testing of ISDN equipment and the RT line circuits of a DLC system will be considered. Similar procedures apply to other types of network equipment.

#### 5.3.3.1 Test Procedure for ISDN Technology

The test circuit shown in [Figure 5-4](#), composed of an actual loop using a cable make-up (length, gauge), exhibits the termination conditions indicated in [Table 5-2](#). Besides [Figure 5-4](#), other test circuits can be used if they exhibit the termination conditions of [Table 5-2](#). In addition, the use of an actual loop may be inconvenient for testing ISDN equipment under the influence of power induction. Therefore, the actual loop can be replaced by a simulation network implemented through the application of artificial cable sections suitable for ISDN operating frequencies (up to 80 kHz). The simulation network consisting of artificial cable sections should exhibit the characteristics indicated in [Table 5-2](#).

Before the test, the circuit shown in Figure 5-4 is to be calibrated to exhibit the termination conditions indicated in Table 5-2 as well as the loop resistance and insertion loss intended for ISDN. A required value of longitudinal current slightly greater than the minimum level is obtained at the CO end with the required voltage applied through an injection transformer at a distance 10 kft from the CO end.

After the test circuit has been calibrated, de-energize the voltage source and connect the CO end of the test circuit to the Line Termination (LT) of the ISDN switching system (see Figure 5-5). At customer end 1, connect the first network (NT1). In series with the first network (NT1) termination, connect the appropriate equipment, such as a Technical Adaptor (TA) or second Network Termination (NT2), that is needed for providing ISDN services on the DSLs. Connect a second NT1 to customer end 2.

A measurement of Bit Error Ratio (BER) will be used to analyze ISDN performance. After it has been determined that the BER at both customers meets the required value of  $10^{-7}$  or less for an ISDN without any voltage applied to the test circuit, the test generator output is increased until the required voltage value is measured across the secondary winding. The BER measurement is repeated with the induction present.

Three units of the equipment are to be tested.

---

**R5-5 [46]** The BER as measured in the presence of the longitudinal induction **shall** be  $10^{-7}$  or less.

---

The BER measurement may be performed on one or more sub-channels (such as B, 2B, or 2B+D). The average time for determination of bit error ratio is to be at least 10 minutes when the bit rate under test is 144 kb/s or more, at least 13 minutes when the bit rate is 128 kb/s, and at least 25 minutes when the bit rate under test is only 64 kb/s.

### 5.3.3.2 Test Procedure for DSL Technologies

DSL technologies shall be tested similar to the test procedure described for ISDN in Section 5.3.3.1. However, DSL technologies are very sensitive to the loop length, and the test circuit of Figure 5-4 proposed for testing ISDN may not be appropriate for all DSL technologies. A test circuit applicable to the tested DSL technology shall be used. For DSL technologies operating in less than 12-kft loop length, the test circuit shall be calibrated to exhibit the induced current ( $I_{CO}$ ) as determined in Note 2 of Table 5-2.

### 5.3.3.3 Test Procedure for RT Line Circuits of a DLC System

The test circuit shown in Figure 5-3 is to be calibrated to exhibit the termination conditions indicated in Table 5-2 as well as the loop resistance and insertion loss intended for the DLC systems, between the RT and the customer end.

After the test circuit has been calibrated, de-energize the voltage source and connect the RT end of the test circuit to the RT line circuit to be tested at customer 1 (see [Figure 5-6](#)). At the customer end, connect the appropriate terminal equipment (such as a single-party station set). Connect a second appropriate piece of terminal equipment to customer end 2. Verify that all operational states (such as on-hook, off-hook, and ringing) of the tested RT line circuit are performing properly. When it has been determined that all operational states are performing properly without any “induced voltage” applied to the test circuit, the test generator output is to be increased until the “required” voltage (126 dBm) is measured across a transformer secondary winding. Repeat the test procedure to verify proper operation in all operating states in the presence of simulated induction.

For DLC services where testing of noise performance is applicable, dial up a connection through the RT line circuit to a quiet termination of the DLC system while applying the “required” voltage indicated in [Table 5-2](#). Hold the connection with a holding circuit (internal to some noise-measuring sets) and disconnect the customer equipment used to dial the call. It is preferable that a mechanical holding circuit is used rather than an electronic holding circuit. Measure the C-Message weighted metallic noise at the customer end with an NMS having a terminating impedance of 600 or 900 ohms.

### 5.3.4 Performance Criteria

All network equipment on short loops that may be influenced by longitudinal induction is to be tested for proper performance using the induction test circuit shown in [Figure 5-3](#). In general, performance criteria of the EUT are given in the applicable Telcordia Generic Requirements, national and international standards. EUT with different operating functions including transient functions shall be tested for each operating function. For example, DSL systems are to be tested for BER as described in [Section 5.3.3.2](#). For analog DLC circuits, all applicable operating functions are to be tested as described in [Section 5.3.3.3](#).

Three units of the equipment are to be tested in each applicable operating function at the “required” test level.

---

**R5-6** [47] The operating functions of the EUT **shall** perform properly when the EUT is connected to the test circuit shown in [Figure 5-3](#) that exhibits the “required” values listed in [Table 5-2](#).

---

“Failure” of an operational function at the “required” level is judged to have occurred when the desired operation malfunctions. For example, the DSL is judged to “pass” when the measured BERs at both customer ends meet the requirement value of  $10^{-7}$  or less for a DSL in the presence of longitudinal induction.

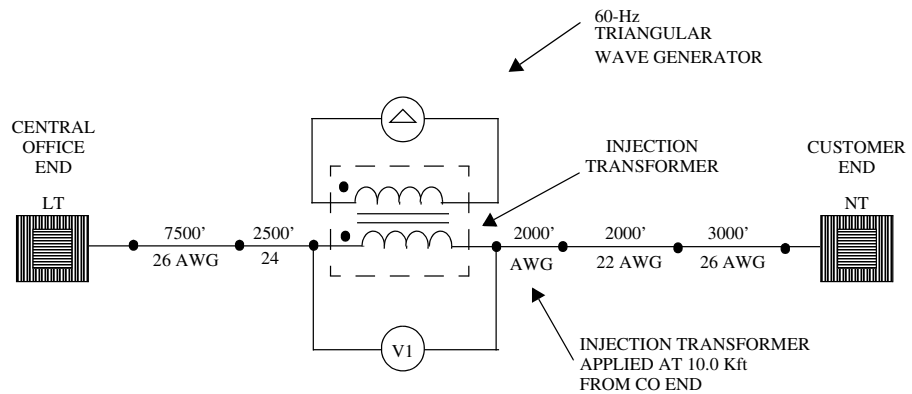
### 5.3.5 Noise Performance for Voiceband Circuits

All network equipment with voiceband circuits on short loops that may be influenced by metallic noise is to be tested for noise performance, using the induction test circuit shown in [Figure 5-3](#).

Three units of the equipment are to be tested at the “required” test level.

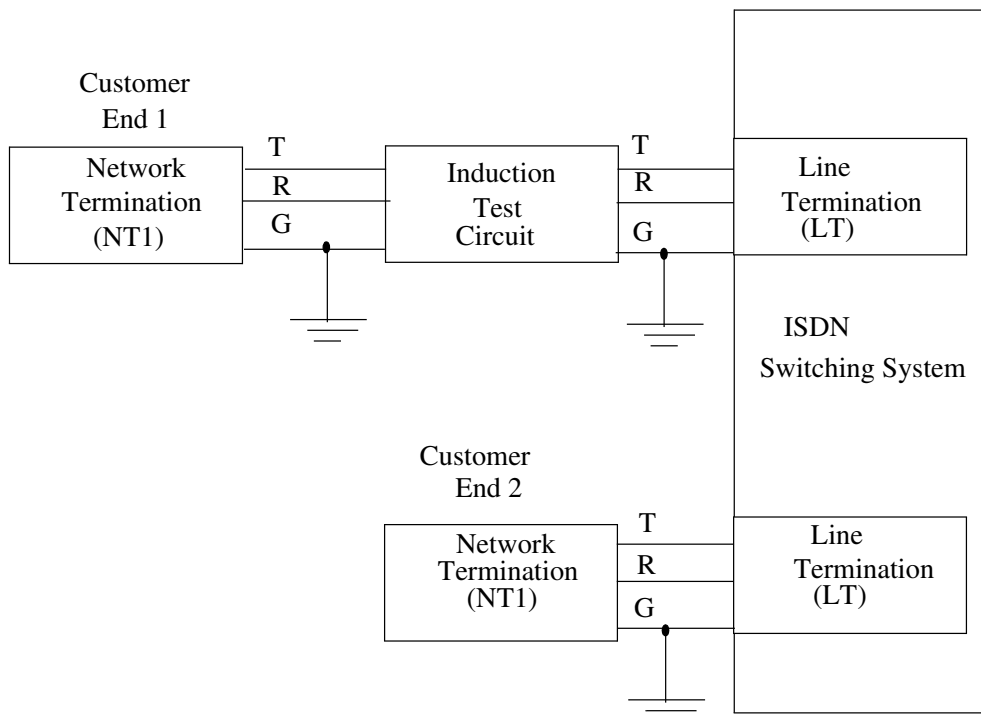
**R5-7 [48]** For network equipment with voiceband circuits, the C-Message weighted metallic noise at the customer end **shall not** exceed 20 dBmC with the “required” value of voltage applied.

**Figure 5-4** Example of Test Circuit Used for Testing ISDN for Longitudinal Induction Immunity Criteria

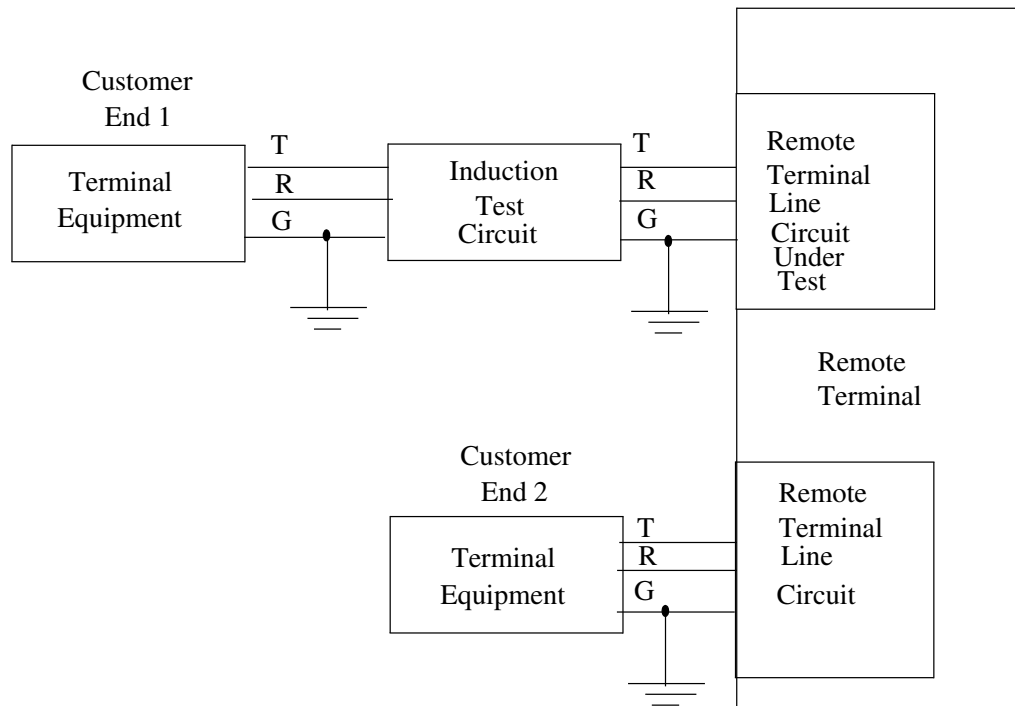


NOTE: Refer to Table 5-2 for termination conditions, circuit parameters, and required parameter values.

**Figure 5-5** Digital Subscriber Line (DSL) Test Arrangement



**Figure 5-6** Digital Loop Carrier (DLC) System, Between Remote Terminal (RT) and Customer End, Test Arrangement



#### 5.4 Longitudinal Induction Criteria for Analog Trunks

The longitudinal induction test circuit simulates a long subscriber loop under the influence of power induction. It consists of a two-port loop simulation network and an injection transformer for the application of the longitudinal test voltages (see [Figure 5-7](#)). The loop simulation network may be implemented either through the use of 3-wire (tip, ring, and ground) artificial cable sections and loading coils, actual telecommunications cable, or by comparable lumped element networks. For 4-wire circuits (two pairs of tip and ring), each pair of wires shall be subjected to steady-state power induction using the test circuit of [Figure 5-7](#).

For trunk circuit testing, the loop simulation network is modified so that the injection transformer is located near the center (45% to 55%) of the simulated length of the test circuit to represent a uniform induction exposure (see [Figure 5-7](#)). The injection transformer should have a minimum of three closely coupled windings contained on a ferromagnetic core (a minimum of a 5-winding transformer would be required for testing 4-wire circuits). The waveform of the applied test voltage should be a 60-Hz triangular wave with positive-going and negative-going excursions symmetrical about each peak.

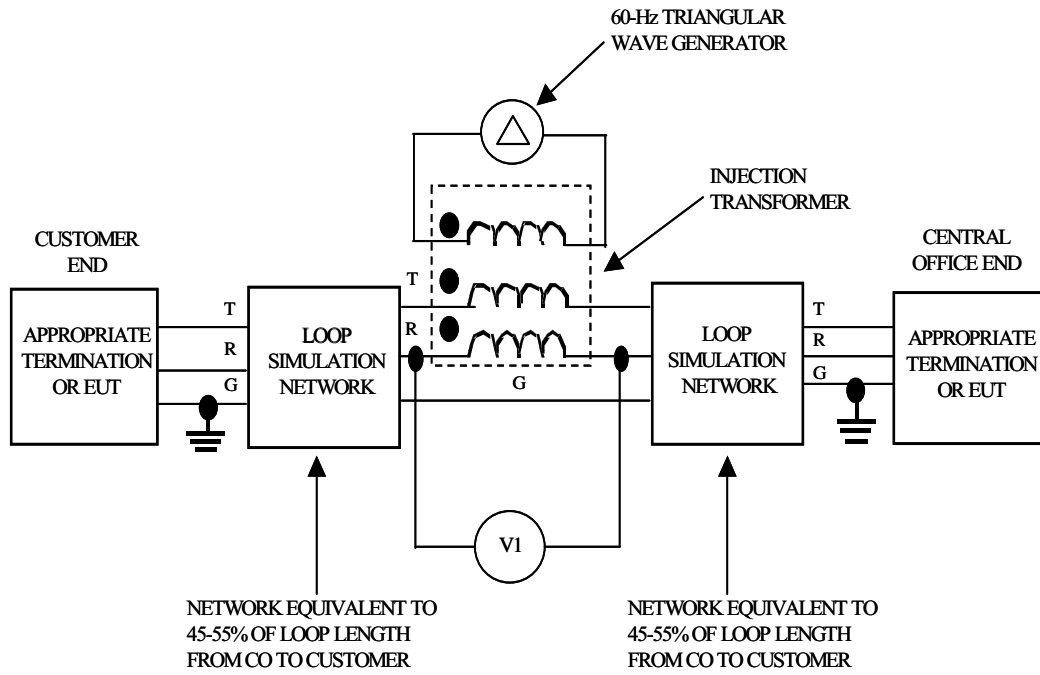


Analog trunk circuits and DLC system interfaces between the RT and the COT are to be tested with the longitudinal induction test circuit that simulates a trunk under the influence of power induction. The loop simulation network may be realized through the use of 3-wire artificial cable sections and loading coils. Loading coils of 66 mH should be used separated by 6-kft cable sections. The loading coils should be separated by 3-kft cable sections from the CO end, the customer end and the injection transformer windings.

#### 5.4.1 Longitudinal Induction Test Circuit for Trunks

Table 5-3 contains the longitudinal induction test circuit criteria for trunks intended to be applied in a long loop when analyzed as shown in Figure 5-7. The circuit shown in Figure 5-7 is to be designed and calibrated to exhibit the “required” and “conditional required” values of the parameters listed in Table 5-3.

**Figure 5-7** Longitudinal Induction Test Circuit for Trunk Circuits



**NOTES:**

Refer to Table 5-3 for termination conditions, circuit parameters, and required and conditional parameter values.

Refer to Appendix B for categorization of the EUT Port as applicable to the “Central Office End” (Port Type 1) and “Customer End” (Port Type 3).

The applied voltage may be monitored by a voltage meter (V1) across any spare winding of the injection transformer.

**Table 5-3** Longitudinal Induction Test Circuit Criteria for Trunks

Termination Conditions	Parameter	Required Value	Conditional Required Value
1, 2, 3	Applied voltage (triangular wave) across injection-transformer secondary winding (0 dBrn = 24.5 $\mu$ V across 600 ohms)	$\geq 126$ dBrn (50 V rms)	$\geq 130$ dBrn (80 V rms)
1	Longitudinal voltage at either end of circuit ( $V_{co}$ )	119 to 121 dBrn (22.5 to 27.5V rms)	123 to 125 dBrn (36 to 44V rms)
2	Total short-circuit current ( $I_{cs}$ ) per pair	$\geq 40$ dBmA (100 mA rms)	$\geq 44$ dBmA (160 mA rms)
3	C-Message noise-to-ground at customer end	86 $\pm 1$ dBrnC	90 $\pm 1$ dBrnC
3	C-Message weighted metallic noise at customer end	10 to 12 dBrnC	14 to 16 dBrnC
Not Applicable	Applied Voltage ( $V_1$ )	$\geq 126$ dBrn (50 V rms)	$\geq 130$ dBrn (80 V rms)
Not Applicable	Voltage injection point (distance from CO end to customer end)	45% to 55%	45% to 55%
Not Applicable	Loop resistance for analog trunks	1200 to 1500 $\Omega$	1200 to 1500 $\Omega$
Not Applicable	Insertion loss for analog trunks (1000 Hz, between 600- or 900-ohm impedances)	4.5 to 8.5 dB	4.5 to 8.5 dB

*Notes to Table 5-3:*

1. A two-letter subscript is used to describe the induced currents and voltages. The first letter of the subscript shows the end at which the measurement was made: "c" for the CO end, and "s" for customer (subscriber) end. The second letter of the subscript shows the termination condition at the other end: "o" for open circuit, and "s" for short circuit. For example, the subscript "co" means that the measurement was made at the CO end (c) with an open circuit at the customer end (o).
2. If the EUT is intended for a system that operates within a specific maximum loop length ( $L_{max}$ ), the test circuit should be designed and calibrated to exhibit the termination conditions of Table 5-3 within the maximum operating loop length.
3. The conditional required values of Table 5-3 are applicable for systems that operate in loop lengths greater than 20 kft.

4. A common-mode capacitance ( $C_g$ ) of 120 nF/km is used for designing the test circuit. However, this value may vary from 100 to 150 nF/km.
5. Termination Conditions (see [Figure 5-7](#)):
  - a. Open circuit at both ends.
  - b. At one end: 250 ohms from tip to ground, 250 ohms from ring to ground. At other end: tip and ring shorted to ground through 10 ohms.
  - c. At one end: open circuit. Measure noise-to-ground with high-impedance NMS; measure metallic noise with NMS having 600- to 900-ohm terminating impedance. At other end: well-balanced 600- to 900-ohm termination with grounded center tap (longitudinal impedance of termination not to exceed 200 ohms).

#### 5.4.2 Calibration Procedure

The test circuit shown in [Figure 5-7](#) is to be calibrated to exhibit the characteristics indicated in [Table 5-3](#). Calibration measurements are to be made using an NMS with 3-kHz flat weighting. The input impedance of the NMS is to be at least 100 kilohms from each input terminal to ground. A true rms meter may be used for calibrating the test circuit.

#### 5.4.3 Test Procedure

Based on the Port Type 1 or 3 under test, the EUT is placed in the test circuit at the appropriate location as described in [Appendix B](#), either the CO end or the far end, and the other end is terminated by representative equipment necessary for the EUT to perform its design-intended functions.

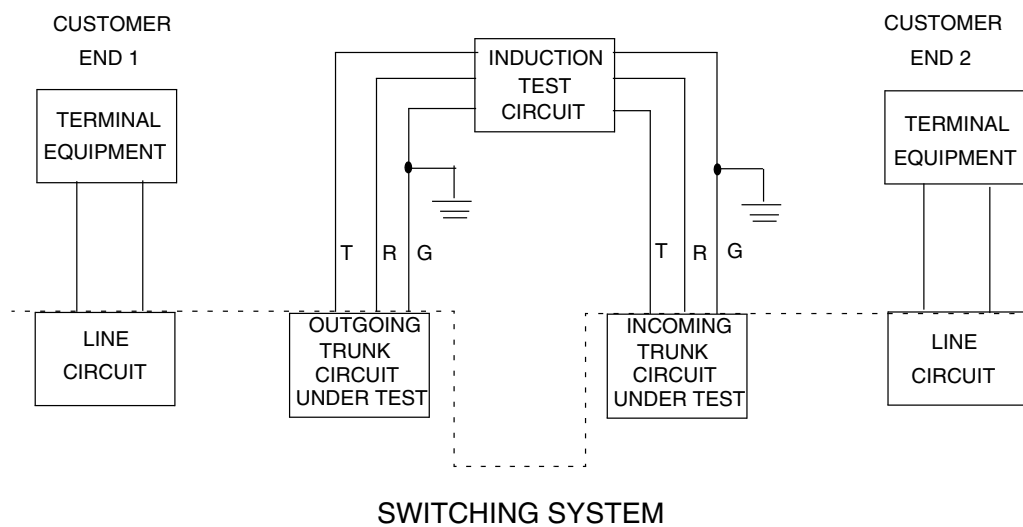
To simplify the discussion of the testing procedure, the testing of analog trunk circuits and DLC system interfaces will be considered. Similar procedures apply to other types of network equipment.

##### 5.4.3.1 Test Procedure for Analog Trunk Circuits

After calibration, de-energize the voltage source and connect the test circuit between an outgoing trunk circuit and an incoming trunk circuit of the switch as shown in [Figure 5-8](#). Connect telephone sets to customer ends 1 and 2 so that a complete communication path is established from one customer station to the other. Similar to the method used for testing line circuits, process calls through the switch to determine that all operational states are performing properly. When it has been determined that correct operation occurs without any voltage applied to the test circuit, apply the test voltage and repeat the call processing to determine normal trunk circuit operation in the presence of the simulated induction. This procedure tests both outgoing and incoming trunk circuits simultaneously. Tests are to be performed at both the “required” and “conditional required” values of voltage and current listed in [Table 5-3](#).

To test the noise performance, establish a connection between customer ends 1 and 2 in the talk state while applying the “required” voltage indicated in Table 5-3 (termination condition 3). Hold the connection with a holding circuit at customer end 1 and disconnect the station equipment used to dial the call. It is preferable that a mechanical holding circuit is used rather than an electronic holding circuit. Repeat the same procedure for customer end 2. In a similar manner, the test is to be performed while applying the “conditional required” level of voltage indicated in Table 5-3.

**Figure 5-8** Analog Trunk Circuit Test Arrangement



#### 5.4.3.2 Test Procedure for DLC System Interfaces Between RT and COT

After the test circuit has been calibrated, de-energize the voltage source and connect the test circuit between the RT and the COT interfaces as shown in Figure 5-9. Connect appropriate terminal equipment (such as a single-party station set) to customer ends 1 and 2 so that a complete communication path is established from one customer station to the other. Verify that all operational states (e.g., on-hook, off-hook, ringing, etc.) of the tested DLC system interfaces, RT and COT, are performing properly. When it has been determined that all operational states are performing properly without any “induced voltage” applied to the test circuit, apply the test voltage and repeat the procedure to verify proper operation in all operating states in the presence of simulated induction. Tests are to be performed at both the “required” and “conditional required” values of voltage and current listed in Table 5-3.

For DLC services for which testing noise performance applies, establish a connection between customer ends 1 and 2 in the talk state while applying the “required” voltage indicated in Table 5-3 (termination condition 3). Hold the connection with a holding circuit at customer end 1 and disconnect the customer

equipment used to dial the call. Measure the C-Message noise metallic at the customer end with an NMS having 600- or 900-ohm terminating impedance. Repeat the same procedure for customer end 2. In a similar manner, the test is to be performed while applying the “conditional required” level of voltage indicated in [Table 5-3](#).

#### 5.4.4 Performance Criteria

Trunk equipment that may be influenced by power induction is to be tested for proper performance using the induction test circuit shown in [Figure 5-7](#). In general, performance criteria of the EUT are given in the applicable Telcordia Generic Requirements, national and international standards. EUT with different operating functions including transient functions shall be tested for each operating function. For example, all applicable operating functions of analog trunk circuits, including transient functions, are to be tested for proper function with the induction test circuit as described in [Section 5.4.3.1](#). Similarly, all applicable operating functions of analog DLC circuits are to be tested for proper function with the induction test circuit as described in [Section 5.4.3.2](#).

Three units of the equipment in each applicable operating function are to be tested at both the “required” and “conditional required” test levels.

---

**R5-8** [49] The operating functions of the EUT **shall** perform properly when the EUT is connected to the test circuit shown in [Figure 5-7](#) that exhibits the “required” values listed in [Table 5-3](#).

**CR5-9** [50] It is a conditional requirement that the operating functions of the EUT perform properly when the EUT is connected to the test circuit shown in [Figure 5-7](#) that exhibits the “conditional required” values listed in [Table 5-3](#).

---

“Failure” of an operational function at both the “required” and “conditional required” level is judged to occur when the desired circuit operation malfunctions.

#### 5.4.5 Noise Performance for Voiceband Circuits

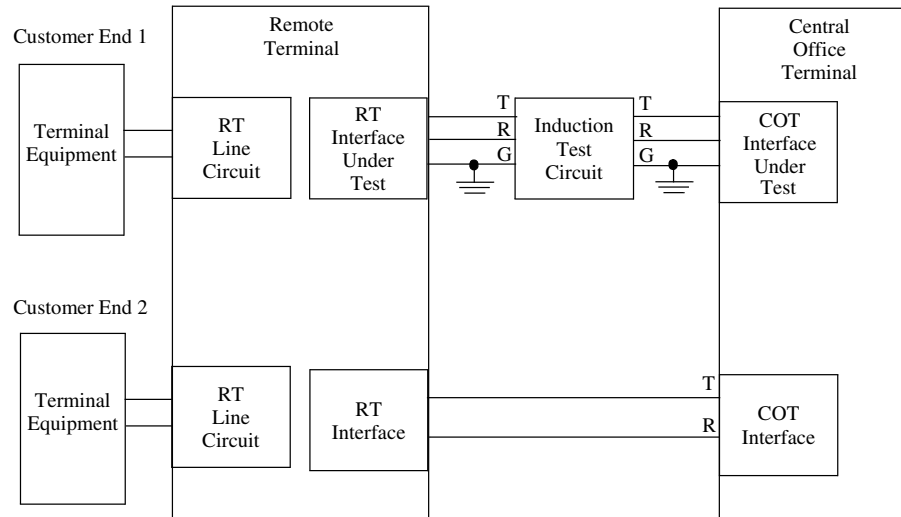
All trunk equipment with voiceband circuits that may be influenced by metallic noise is to be tested for noise performance using the induction test circuit shown in [Figure 5-7](#). Three units of the equipment are to be tested at both the “required” and “conditional required” test levels.

---

**R5-10** [51] The C-Message weighted metallic noise at either subscriber **shall not** exceed 23 dBrnC with the “required” value of voltage applied.

**CR5-11** [52] It is a conditional requirement that the C-Message weighted metallic noise at either subscriber not exceed 23 dBrnC with the “conditional required” value of voltage applied.

---

**Figure 5-9** DLC System, Between RT and COT, Test Arrangement

## 5.5 Longitudinal Induction Criteria for Coaxial Cables

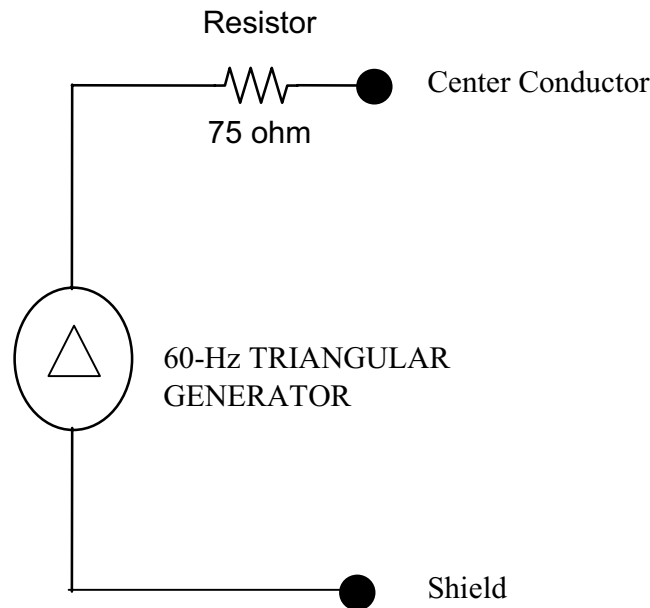
The longitudinal induction test circuit simulates a coaxial cable under the influence of power induction. It consists of a voltage source in series with a resistor as shown in Figure 5-10. The waveform of the applied test voltage should be a 60-Hz triangular wave with positive-going and negative-going excursions symmetrical about each peak.

### 5.5.1 Longitudinal Induction Test Circuit for Coaxial Cables

Table 5-4 contains the longitudinal induction test circuit criteria for network equipment intended to be applied in a coaxial cable when tested using the induction test circuit shown in Figure 5-10. The test circuit of Figure 5-10 should exhibit the “required” and “objective” values of the parameters listed in Table 5-4.

Equipment that functions properly in the presence of the required value of voltage and current can be expected to be immune to most induction environments. Equipment that functions properly in the presence of the objective values of voltage and current can be expected to be immune even in severe induction environments. Such severe environments may be encountered in rural areas where coaxial cables have long exposure to single-phase electric power systems.

**Figure 5-10** Longitudinal Induction Test Circuit for Cables



**Table 5-4** Longitudinal Induction Test Circuit Criteria for Coaxial Cables

Parameter	Required Value	Objective Value
Applied voltage, $V_{in}$ (triangular wave)	15V rms	30 V rms
Resistance, $R_L$	75 $\Omega$	75 $\Omega$
Short-Circuit Current $I_s$	0.2 A	0.4 A

### 5.5.2 Test Procedure

Based on the Type Port 1 or 3 under test, as described in [Appendix B](#), the EUT is placed in the test arrangement shown in [Figure 5-11](#) with the other end terminated by representative equipment necessary for the EUT to perform its design-intended functions.

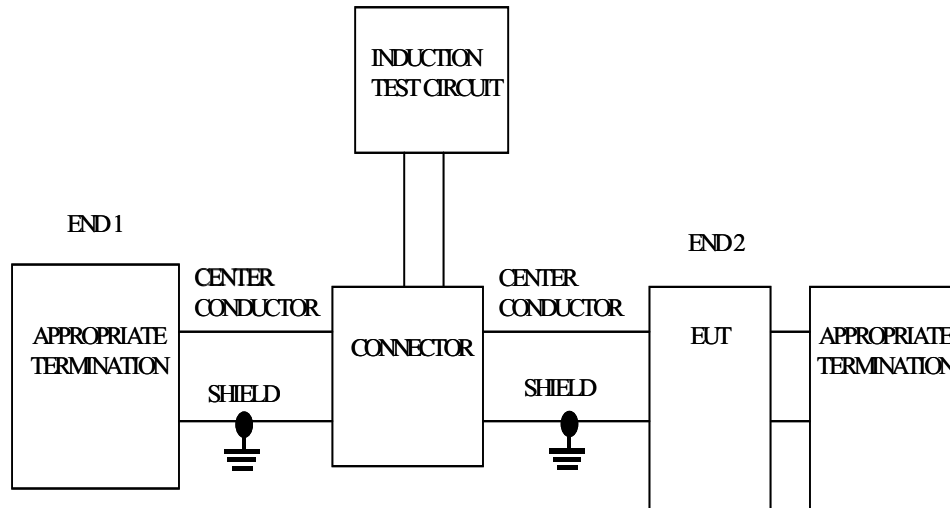
After the test circuit exhibit in [Figure 5-10](#), the parameter values of [Table 5-4](#) de-energize the voltage source and connect it to the test arrangement of [Figure 5-11](#). At end 1, connect the appropriate terminal equipment (such as power). At end 2, connect the EUT. If it is applicable, connect a second piece of appropriate terminal equipment to end 2 to ensure that the EUT performs its design-intended functions (see [Figure 5-11](#)). Use coaxial cables as short as practicable, up to 4 meters in length, to connect the induction test circuit, EUT, and appropriate terminals in [Figure 5-11](#). Verify that the EUT is performing properly.

When it has been determined that normal operation occurs without any “induced voltage” applied to the test circuit, the test generator output is to be increased until the “required” voltage is reached. Repeat the test procedure to verify that the



operation of EUT performs properly in the presence of simulated induction. In a similar manner, tests are to be performed while applying the “objective” level of longitudinal voltage indicated in Table 5-4.

**Figure 5-11** Test Arrangement for Equipment Intended for Coaxial Cables



### 5.5.3 Performance Criteria

All network equipment intended to be used on coaxial cables that may be influenced by longitudinal induction is to be tested for proper performance using the induction test circuit shown in Figure 5-10. In general, performance criteria of the EUT are given in the applicable Telcordia Generic Requirements, national and international standards. EUT with different operating functions, including transient functions, shall be tested for each operating function. The operating functions to be tested depend on the type of EUT as described in Section 5.5.2.

Three units of the equipment are to be tested in each applicable operating function at the “required” and “objective” test level.

**R5-12 [141]** The operating functions of the EUT **shall** perform properly when the EUT is connected to the test circuit shown in Figure 5-10 that exhibits the “required” values listed in Table 5-4.

**O5-13 [142]** The operating functions of the EUT **should** perform properly when the EUT is connected to the test circuit shown in Figure 5-10 that exhibits the “objective” values listed in Table 5-4.

“Failure” of an operational function at the “required” level is judged to have occurred when the desired circuit operation malfunctions.



## 6 DC Potential Difference

A dc potential difference may exist between separate physical locations of network equipment. For example, the earth potential at the CO may be several volts dc different when measured with respect to earth at a remote terminal location. The criterion of this section applies only to network equipment in telecommunications circuits where both ends of one of the telecommunications conductors in the circuit have a reference to ground during its normal operating states (e.g., ground start, coin return, coin deposit, coaxial cable, etc.).

---

**R6-1 [53]** Network equipment **shall** operate properly in the presence of 3 V dc between loop ends.

---

The influence of a dc potential difference on network equipment may be determined by applying a dc potential longitudinally (common mode) between the central-office end and far end of the test circuits shown in [Figure 5-1](#), [Figure 5-3](#), and [Figure 5-7](#) (the ground wire G in these figures should have a 3 Vdc difference between the CO end and far end). Performance of network equipment can be determined by using an appropriate test arrangement. [Figure 5-2](#), [Figure 5-5](#), [Figure 5-6](#), [Figure 5-8](#), and [Figure 5-9](#) show test arrangements for different network systems. Compliance is determined by the proper performance of all design-intended functions of the EUT in all applicable operating states as described in [Section 5](#).



# 7 Electrical Safety Criteria

## 7.1 Overview

Electrical safety criteria are intended to protect persons from harm by limiting the voltages and currents that are intentionally applied to communication circuits and to energized parts of network equipment. Also of concern is the control of leakage currents that may be conducted from exposed surfaces of the equipment. Criteria are presented that restrict access to various levels of voltage. An overall power limitation is imposed on sources that may be applied to communication wiring.

The voltage limits provided in this section correspond to the reading of a voltmeter having an internal impedance much greater than the source impedance. Similarly, current limits correspond to the reading of an ammeter having an internal impedance that is much less than the source impedance.

The term “sources” as used in this section is intended to apply to intentionally energized communications circuits (e.g., conductors, terminals, connectors, components, wire wrap pins). It also applies to any other conductive parts located where incidental contact or maintenance procedures could reasonably result in contact while the equipment is energized.

Equipment is to be evaluated in a manner consistent with its deployment. Determination of accessibility should consider situations where equipment sources are restricted or inaccessible, but are expected to be exposed elsewhere in the intended installation. For example, inaccessible tip and ring circuits may be exposed to various other classes of individuals at locations such as Main Distribution Frames (MDFs), punch down blocks, splices cases, outdoor enclosures and at the customer premises. Therefore, sources intended to be connected to circuits external to the equipment must have a classification appropriate to the accessibility of the circuit.

Equipment that has input “sources” such as terminal blocks and wire wrap pins, etc., must be evaluated considering the sources that are expected to be connected to these inputs. The accessibility level of these input sources should be consistent with the classification of such sources when installed as intended. Examples of this are alarm relay inputs that can have up to 56.7 Vdc applied by alarm monitoring equipment and are Class A2, or uninterrupted CO ring generator inputs that are Class B voltages.

## 7.2 Listing Requirements

This section provides Listing requirements for Network communications equipment. [Appendix D](#) provides the definition of “Listed.”

---

**R7-1 [22]** All network equipment that is directly powered by commercial ac, either through a hard-wire or plug-and-cord connection, **shall** be Listed.

**R7-2 [23]** Inverters that provide power to network equipment or to convenience receptacles **shall** be Listed.

**R7-3 [24]** Network communications equipment that is intended to be located on customer premises **shall** be Listed.

## 7.3 Classification of Voltages

A voltage source is classified as either a continuous or duration-limited source. A continuous source is defined as one that is present for longer than 5 seconds. Duration-limited sources fall into two categories. Voltage sources that are present from 0.01 to 5 seconds are considered to be interrupted/tripped sources. Ringing is an example of an interrupted/tripped voltage source. Voltages of duration less than 0.01 second are considered to be transient voltages.

It may be possible that a source has more than one voltage classification depending on various operating states or modes of operation. In such cases, the voltage classification in each operating state or mode is to be identified.

For some products such as HDSL, which are designed to have a COT and RT device, the source classification of the COT end may differ depending upon the remote unit being installed versus uninstalled, or the remote unit being defective. In these cases, the safety of the COT is to be evaluated with a remote unit connected as in normal service and with the remote unit disconnected as it would be during installation or as a result of a cable problem or defective remote unit. Other sources that may have voltages that may behave differently depending upon being terminated or not shall be investigated in a similar manner.

**R7-4 [143]** Electrical safety testing **shall** be performed with EUT energized as in normal operation. Where applicable, external voltage sources, i.e., voltages applied to EUT by other equipment, **shall** be present during testing. In the case that the external source cannot be specifically identified, the source **shall** be classified considering the worst case of GR-1089-CORE class source that is expected to connect to the EUT.

When EUT generates voltages, the electrical safety testing **shall** be performed including the host system. The sources appearing on the EUT and the sources on the host system arising from the EUT **shall** be classified.

**NOTE:** See ANSI T1.337/2003<sup>[48]</sup> for requirements for maximum dc steady-state and duration-limited voltage, current, and power limits to be observed for network-powered telecommunication equipment at customer premises designed to be connected to the telecommunications network and forming part of the customer's installation.

### 7.3.1 Continuous Voltage and Current Limits

A frequency-weighted equivalent ac voltage,  $V_e$ , is used to take into account the frequency dependence of the skin resistance and the let-go current threshold when defining continuous voltage limits. The equivalent ac voltage,  $V_e$ , of a sinusoidal waveform of frequency  $f$  and peak amplitude  $V$  is

$$V_e = W(f) V \tag{7-1}$$

where

$$W(f) = 1.0 \quad \text{if } 0 < f < 60 \text{ Hz}$$

$$W(f) = \left( \frac{0.75}{1 + \frac{f}{2200}} \right) \left[ \frac{1 + \left( \frac{f}{65} \right)^2}{1 + \left( \frac{f}{930} \right)^2} \right]^{1/2} \quad \text{if } 60 \text{ Hz} \leq f \leq 10 \text{ kHz} \tag{7-2}$$

$$W(f) = 1.93 \quad \text{if } 10 \text{ kHz} < f$$

and  $f$  is the frequency in Hz of component  $V$ .

Similarly, a frequency-weighted equivalent current,  $I_e$ , is used for a sinusoidal current waveform of peak amplitude  $I$ , and is defined by

$$W(f) = \frac{I}{I + \frac{f}{2200}} \quad \text{if } 0 < f \leq 10 \text{ kHz} \tag{7-3}$$

$$W(f) = 0.18I \quad \text{if } 10 \text{ kHz} < f$$

where  $f$  is the frequency in Hz.

For an ac signal composed of more than one frequency component, the sum of the equivalent voltages or equivalent currents of the individual components is the relevant parameter.

---

**R7-5 [115]** Continuous source voltage limits (and current limits, as appropriate) **shall** apply between each terminal and ground with all other terminals connected as in normal service. The limits **shall** also apply between each terminal and ground with all other terminals open circuited. For paired-conductor sources, i.e., telecommunications or similar circuits, the limits also **shall** apply with all other terminals individually grounded.

---

When it is necessary to classify current limits, a variable resistance shall be placed between the source terminal under test and ground. The voltage and current (load line) shall be plotted using different resistance values between 0  $\Omega$  and the maximum test resistance values specified in [Table 7-1](#). The load line shall first be determined with all associated terminals connected as in normal service, and then repeated with all associated terminals open-circuited. For paired-conductor sources, i.e., telecommunications or similar circuits, the limits also apply with all associated terminals individually grounded. Sufficient data points shall be identified

to ensure compliance with the appropriate limits in [Figure 7-1](#) through [Figure 7-3](#). A minimum set of test points is to include 0, 200, 2000, 5000, 10000, and 20000 Ω for all Classes; 40000 Ω for Class A2 or A1; and 1.3 MΩ for Class A1.

**Table 7-1** Values of Maximum Test Resistance

Class	Maximum Test Resistance
A1	1.3 MΩ
A2	40 kΩ
A3	20 kΩ

Means of limiting continuous voltages and currents available to personnel, such as ground fault detection and complete shutdown of the continuous source under fault conditions, is permissible provided voltages and currents do not exceed the levels specified throughout this section.

**R7-6 [144]** Sources utilizing ground fault detection or voltage shutdown **shall** be evaluated against transient sources requirements of [Section 7.5.2](#).

Continuous voltages are divided into Classes A1, A2, and A3 (each of which may be contacted barehanded), Class AB, Class B, and Class C.

Sources standardized by the industry with voltages and currents that are known to be within Class A1 do not need to be tested. Examples of such sources are RS-232, V.35, X.25, DSX-1, E1, DS3, USB, and Ethernet technologies compliant with IEEE 802.3 standards (10Base-T, 100Base-T, etc.), with the exception of Power over Ethernet technology (based on IEEE 802.3af standard).

### 7.3.1.1 Class A1 Voltage Limits

Class A1 voltages are those causing currents in excess of leakage limits of [Section 7.7](#), but not greater than the following.

1. DC Voltages — 30 V to ground. Voltages exceeding 30 V, but less than 200 V, are acceptable if the current is limited to 0.15 mA dc. The load line of a dc Class A1 source is contained entirely within the acceptable region shown in [Figure 7-1\(a\)](#).
2. AC Voltages — Equivalent voltages of 14.1 V peak to ground. Equivalent voltages exceeding 14.1 V peak, but less than 200 V peak, are acceptable if the equivalent current is limited to 0.15 mA peak. The load line of an ac Class A1 source is contained entirely within the acceptable region shown in [Figure 7-1\(b\)](#).
3. Combined AC and DC Voltages — The limits on combined equivalent ac and dc voltages to ground are indicated by the acceptable region shown in [Figure 7-1\(c\)](#). However, higher combined voltages up to 200 V peak are acceptable if the peak equivalent ac current component,  $I_e$ , and dc current component,  $I_{dc}$ , satisfy

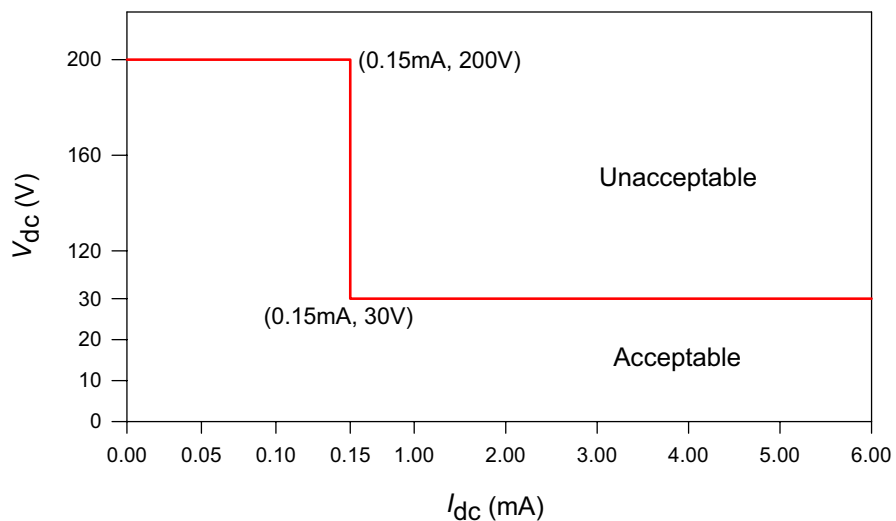
$$\frac{|I_e|}{0.15\text{mA}} + \frac{|I_{dc}|}{0.15\text{mA}} \leq 1 \tag{7-4}$$

as shown in [Figure 7-1\(d\)](#).



**Figure 7-1 Class A1 Voltage Limits (Sheet 1 of 2)**

(a) DC Only



(b) AC Only

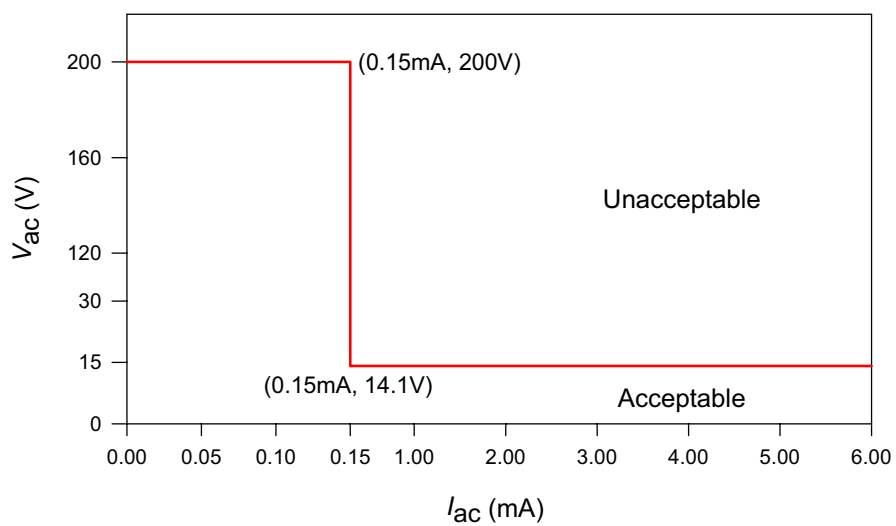
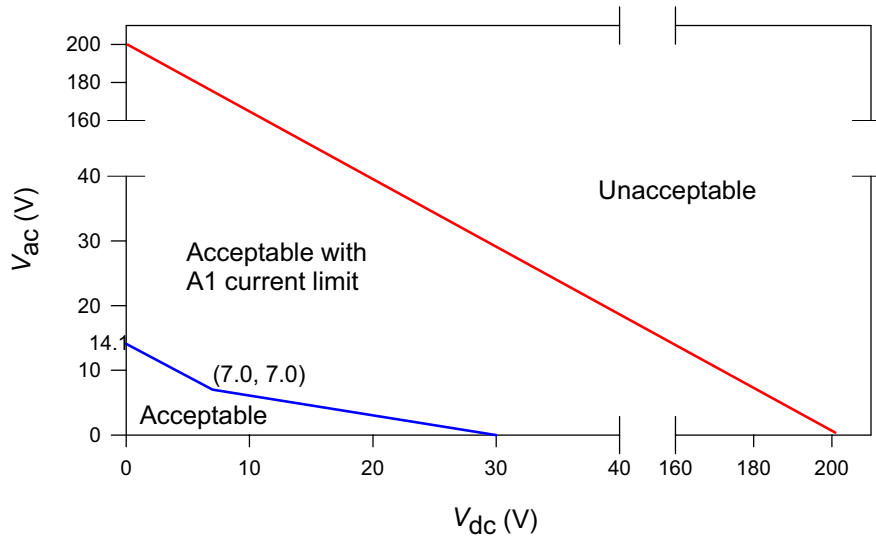
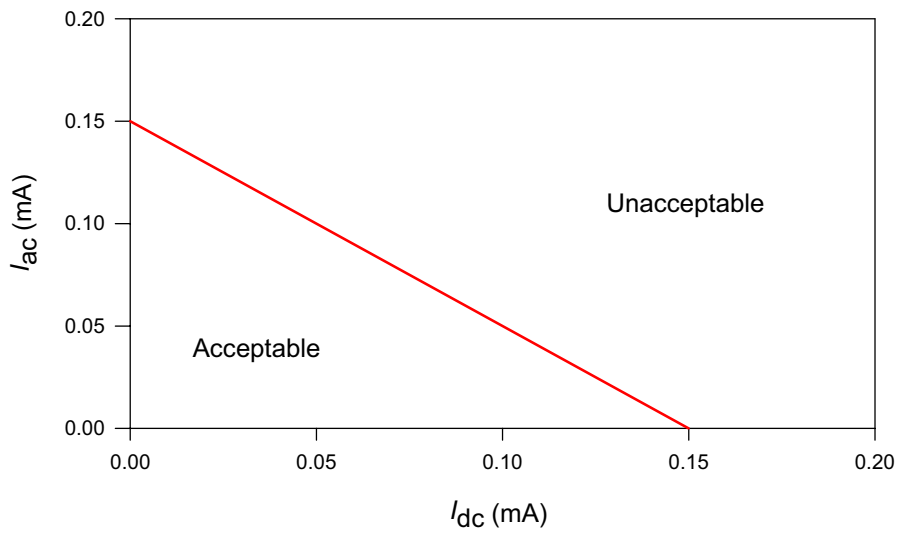


Figure 7-1 Class A1 Voltage Limits (Sheet 2 of 2)

(c) AC and DC Combined



(d) Current Limit for Higher Combined Voltages



### 7.3.1.2 Class A2 Voltage Limits

Class A2 voltages are those that are in excess of Class A1 limits but not greater than the following.

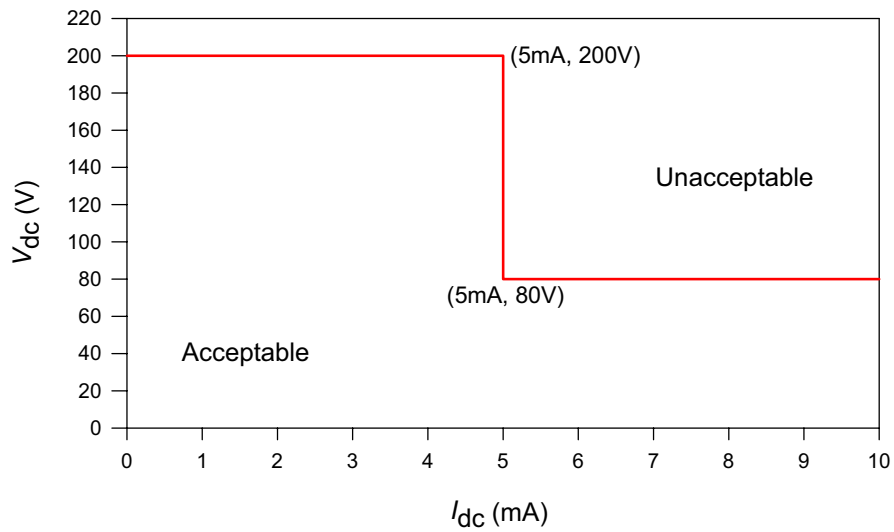
1. DC Voltages — 80 V to ground. Voltages exceeding 80 V, but less than 200 V, are acceptable if the current is limited to 5 mA dc. The load line of a dc Class A2 source is contained entirely within the acceptable region shown in [Figure 7-2\(a\)](#).
2. AC Voltages — Equivalent voltages of 42.4 V peak to ground. Equivalent voltages exceeding 42.4 V peak, but less than 200 V peak, are acceptable if the equivalent current is limited to 1.0 mA peak. The load line of an ac Class A2 source is contained entirely within the acceptable region shown in [Figure 7-2\(b\)](#).
3. Combined AC and DC Voltages — The limits on combined equivalent ac and dc voltages to ground are indicated by the acceptable region shown in [Figure 7-2\(c\)](#). However, combined voltages up to 200 V peak are acceptable if the peak equivalent ac current component,  $I_e$ , and the dc current component,  $I_{dc}$ , satisfy

$$\frac{|I_e|}{1 \text{ mA}} + \frac{|I_{dc}|}{5 \text{ mA}} \leq 1 \quad (7-5)$$

as shown in [Figure 7-2\(d\)](#).

**Figure 7-2 Class A2 Voltage Limits (Sheet 1 of 2)**

(a) DC Only



(b) AC Only

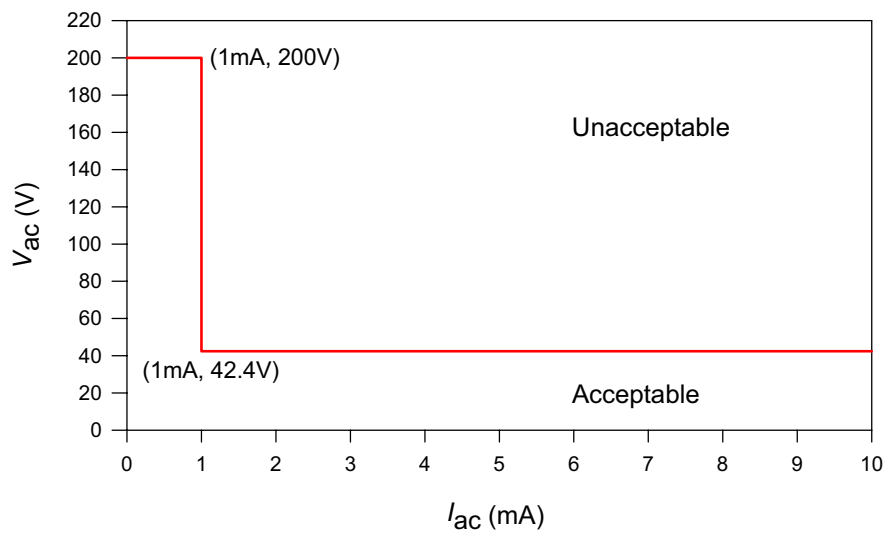
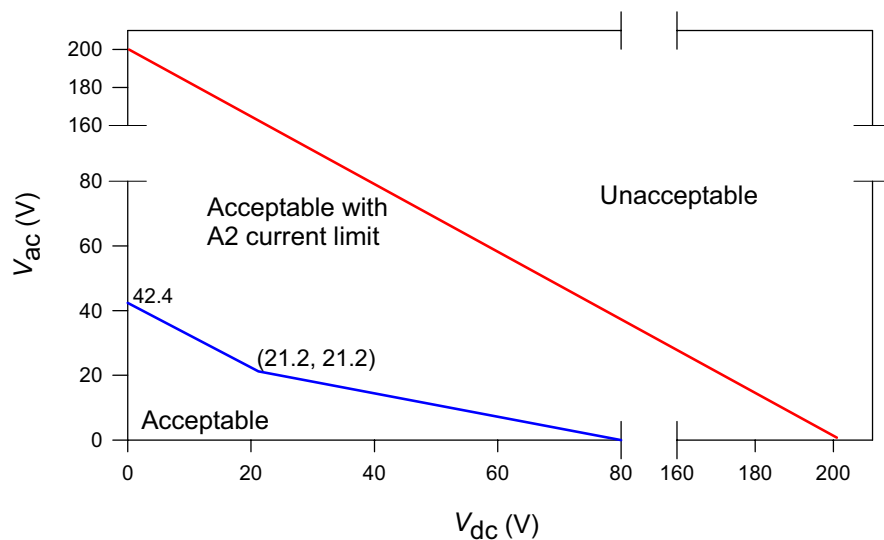
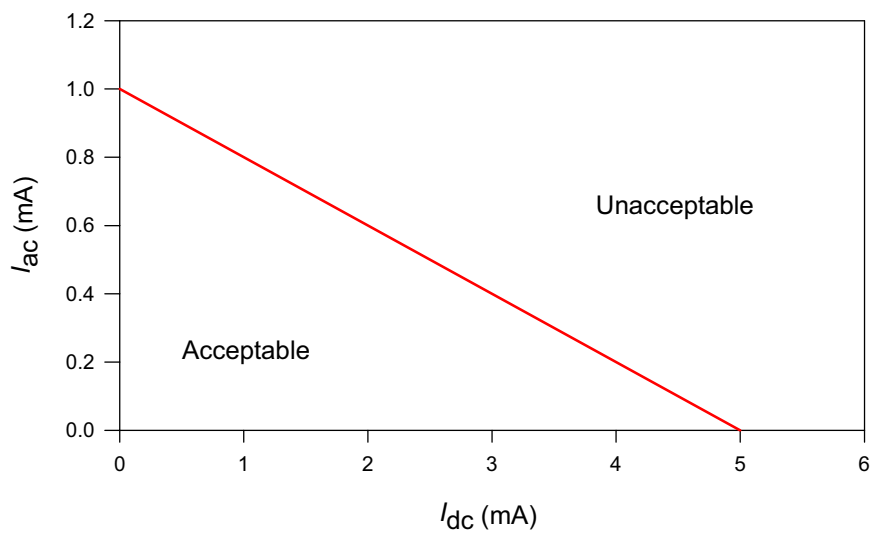


Figure 7-2 Class A2 Voltage Limits (Sheet 2 of 2)

(c) AC and DC Combined



(d) Current Limit for Higher Combined Voltages



### 7.3.1.3 Class A3 Voltage Limits

Class A3 voltages represent the upper limit of voltages that may be contacted barehanded. Special precautions in the design and handling of equipment or facilities using Class A3 voltages are necessary.

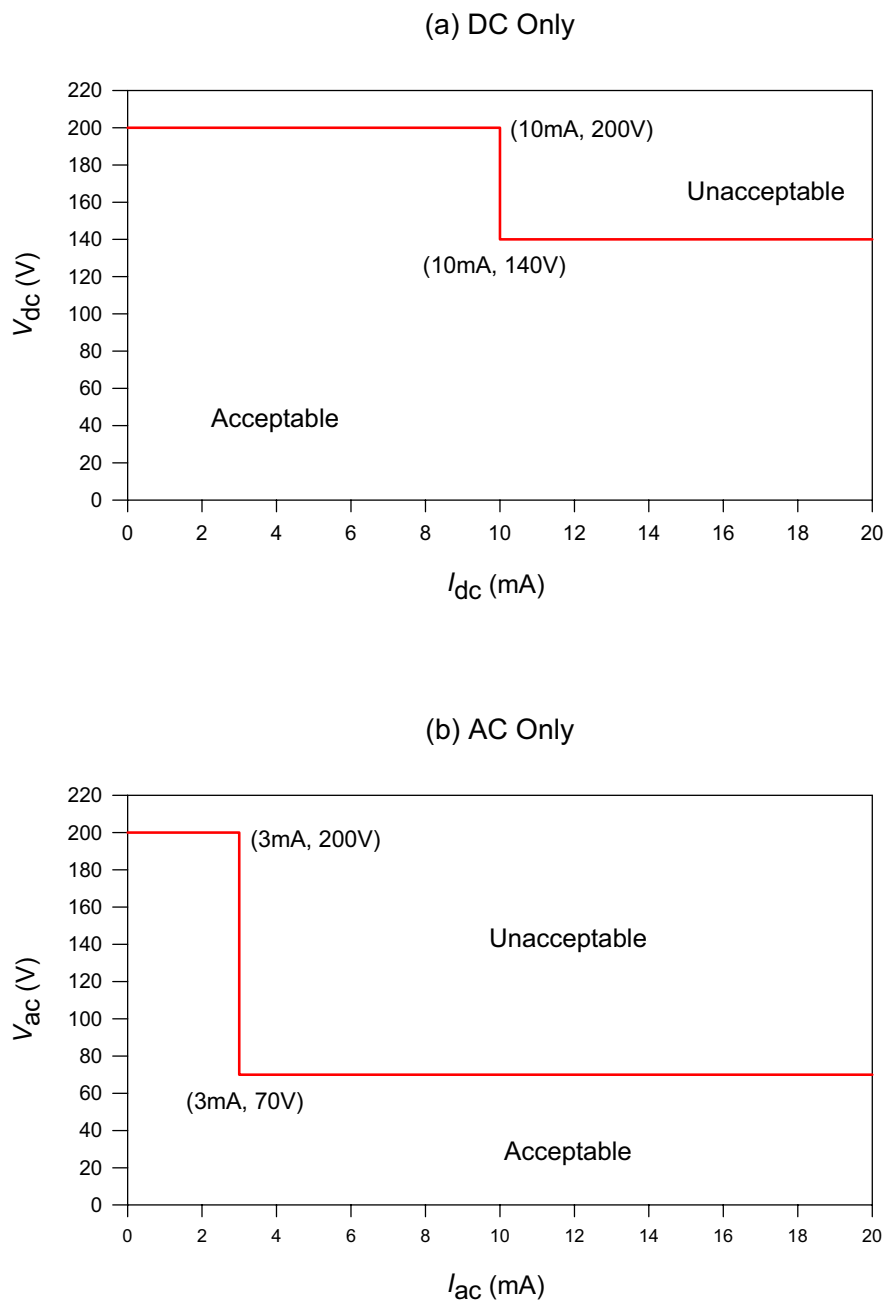
Class A3 voltages are voltages in excess of Class A2 limits, but not greater than the following:

1. DC Voltages — 140 V to ground. Voltages exceeding 140 V, but less than 200 V, are acceptable if the current is limited to 10 mA dc. The load line of a dc Class A3 source is contained entirely within the acceptable region shown in [Figure 7-3\(a\)](#).
2. AC Voltages — Equivalent voltages of 70 V peak to ground. Equivalent voltages exceeding 70 V peak, but less than 200 V peak, are acceptable if the equivalent current is limited to 3 mA peak. The load line of an ac Class A3 source is contained entirely within the acceptable region shown in [Figure 7-3\(b\)](#).
3. Combined AC and DC Voltages — The limits on combined equivalent ac and dc voltages to ground are indicated by the acceptable region shown in [Figure 7-3\(c\)](#). However, combined voltages up to 200 V peak are acceptable if the peak equivalent ac current component,  $I_e$ , and the dc current component,  $I_{dc}$ , satisfy

$$\left[ \frac{I_e}{3 \text{ mA}} \right]^{\frac{1}{2}} + \left[ \frac{I_{dc}}{10 \text{ mA}} \right]^{\frac{1}{2}} \leq 1 \quad (7-6)$$

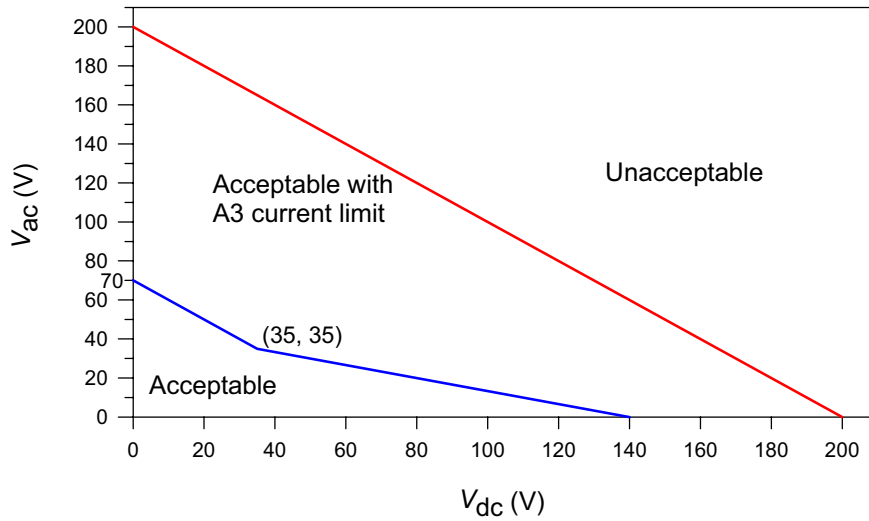
as indicated in [Figure 7-3\(d\)](#).

Figure 7-3 Class A3 Voltage Limits (Sheet 1 of 2)

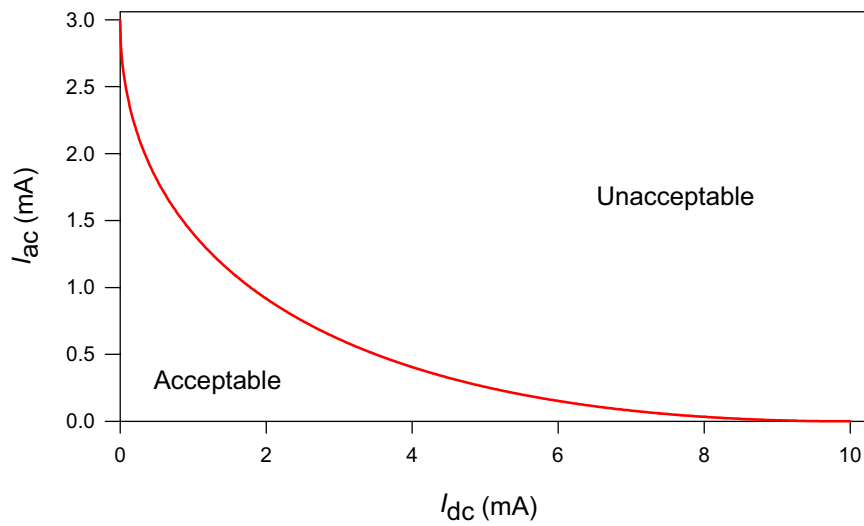


**Figure 7-3 Class A3 Voltage Limits (Sheet 2 of 2)**

(c) AC and DC Combined



(d) Current Limit for Higher Combined Voltages





#### 7.3.1.4 Class AB Voltage Limits

Class AB voltages are those that exceed Class A3 limits, but are below 90 V dc to ground or 90 V ac rms to ground. Available currents of up to 15 amperes and power levels of up to 1350 volt-amperes are permitted. Class AB voltages are intended only for OSP systems powering applications over Coaxial Cable (COAX).

#### 7.3.1.5 Class B Voltage Limits

Class B voltages are those that exceed Class A3 limits, but are below 600 V dc to ground or 600 V ac to ground or 1000 V ac rms between metal parts.

#### 7.3.1.6 Class C Voltage Limits

Class C voltages are those that exceed Class B limits. Class C sources require protection beyond the scope of this document.

### 7.4 Continuous Source Requirements

Continuous source requirements give the maximum voltage, current, and associated level of accessibility that may be provided to three classes of individuals as a function of their level of training. The first level of individuals is the “general public.” It is assumed that the general public is unfamiliar with electrical hazards. They are not intended to have access to energized conductors or parts. However, the general public may interface with network equipment that is located on customer premises, such as a Network Interface Device (NID), protector, or optical network unit, or network equipment that is located in the OSP, such as equipment cabinets and enclosures. The second level of individuals is telecommunication company employees in general — “employees.” These are individuals, such as operators, who might interface with network equipment while performing an administrative or service function. The third level of individuals is craftspersons who are trained to work with powered communication circuits. These individuals access energized parts of network equipment in a CO or similar environment, outside plant, or at the customer premises.

Three levels of diminishing accessibility are defined: exposed, restricted access, and inaccessible. Accessibility to energized conductors or parts is determined by the use of the test finger of [Figure 7-4](#). This test finger is taken from [Figure 2A](#) of [UL60950-1<sup>\[33\]</sup>](#) that is modified by extending Part 3 of the UL test finger by 10 mm. The extension can be made by inserting a 10 mm stub that has the same cross section dimensions as Part 3 of UL test finger. The distance between the tip of the test finger and the insulating material is 90 mm as shown in [Figure 7-4](#). Also, this test figure requires the use of 5.08-cm disk as shown in [Figure 7-4](#).

A source is exposed if it may be contacted with the test finger shown in [Figure 7-4](#) where dimension “A” is 3.5 cm (1.38 inches).

A source has restricted access if it is not exposed, but may be contacted with the test finger where dimension “A” is 9.0 cm (3.54 inches).

A source is inaccessible if it cannot be contacted with the test finger where dimension “A” is 9.0 cm (3.54 inches). The accessibility to a given class of individuals is determined with equipment enclosures in place, which would be in place during normal operation by that class of individual.

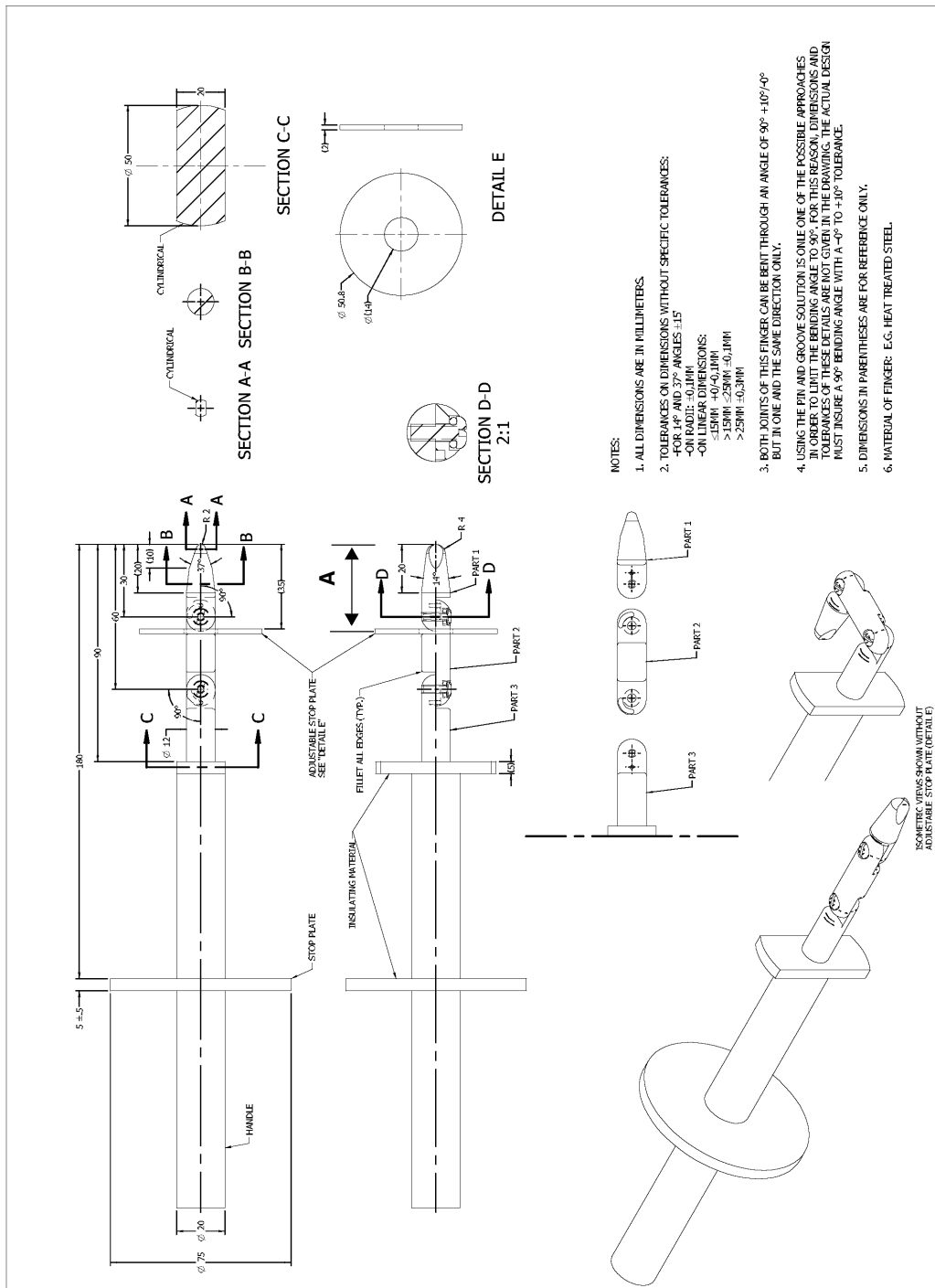
When the continuous source requirements are applied, it will be necessary to determine the training level of individuals (such as the general public or craftsmen) that are expected to interface with the equipment. Table 7-2 is provided as a guide in applying the continuous source accessibility requirements of Section 7.4.1, Section 7.4.2, and Section 7.4.3 of this document.

**NOTE:** COs, EEEs, EECs, and similar telecommunications facilities are considered accessible to craftsmen only.

**Table 7-2.** Accessibility to Continuous Class-A Voltages

Voltage Class	General Public	Employees	Craftsmen
A1	Restricted Access	Exposed	Exposed
A2	Inaccessible	Restricted Access	Exposed
A3	Inaccessible	Inaccessible	Restricted Access (Exceptions)

Figure 7-4 Test Finger



### 7.4.1 Class A1 Voltage Accessibility Requirements

**R7-7 [54]** Class A1 voltage sources **shall** be inaccessible or have restricted access for contact by the general public and may be exposed for contact by employees and craftspersons. Shrouded or guarded connections or sources with Class A1 voltages appearing on their pins or “connection means” (i.e., screws, headers, wire wrap posts, gold fingers, etc.) are considered to provide adequate protection of the general public and employees from these sources.

### 7.4.2 Class A2 Voltage Accessibility Requirements

**R7-8 [55]** Class A2 voltage sources **shall** be inaccessible for contact by the general public, **shall** be inaccessible or have restricted access for contact by employees, and may be exposed for contact by craftspersons. The general public and employees are adequately protected from contact with Class A2 voltages if these sources appear on the pins or other “connection means” of shrouded or guarded connectors or sources.

A shrouded or guarded connection is a connection means where inadvertent access with the sources is unlikely. The shrouded or guarded connection shall have the following characteristics:

- Contact by a large part of the human body, such as the back of the hand, is impossible.
- Contact is possible only by deliberately inserting a small part of the body, less than 12 mm across, such as a fingertip, which presents a high impedance.
- In case of AC voltage, the possibility of being unable to let go of the part in contact does not arise.

Examples of compliant shrouded connections are: modular plugs and jacks, miniature ribbon cables, and D sub-miniature connectors.

### 7.4.3 Class A3 Voltage Accessibility Requirements

**R7-9 [56]** Class A3 voltage sources **shall** be inaccessible for contact by the general public and employees. Equipment that is powered by or that generates Class A3 voltage **shall** have restricted access for contact by craftspersons or **shall** be exposed for contact by craftspersons with the following precautions.

**R7-10 [57]** When an enclosure or baffle is removed, or energized electrical circuits are otherwise exposed for contact by craftspersons, Class A3 sources **shall** be segregated from Class A1 and Class A2 sources by appropriate insulation, baffling, or location to prevent inadvertent contact.

**R7-11 [58]** Designed appearances of Class A3 voltage sources on equipment that is powered by or that generates such voltages **shall** be labeled where craftspersons are normally intended to contact them for service operation.

#### 7.4.4 Class AB Voltage Accessibility Requirements

- 
- R7-12 [59]** Class AB voltage sources **shall** be restricted to systems powering applications confined to the OSP and utilizing COAX.
- R7-13 [60]** Class AB voltage sources **shall** be inaccessible for contact by the general public and employees. Equipment that is powered by, or that generates, Class AB voltage **shall** have restricted access for contact to the Class AB voltage by craftspersons.
- R7-14 [61]** Bare-handed contact with Class AB voltages **shall not** be permitted. Rubber gloves and eye protection **shall** be worn when working on conductors energized to Class AB voltages.
- R7-15 [62]** Designed appearances of Class AB voltage sources on equipment that is powered by, or that generates, such voltages **shall** be labeled where craftspersons are normally intended to access them for service operations.
- 

#### 7.4.5 Class B Voltage Accessibility Requirements

- 
- R7-16 [63]** Class B voltage sources **shall** be de-energized before contact is allowed. With normal equipment enclosures in place, it **shall not** be possible to contact Class B sources with the test finger shown in [Figure 7-4](#) where dimension “A” is 9 cm (3.54 inches). Protection covers carrying warning labels for Class B sources **shall not** be removable without the use of tools and/or a key. When an enclosure or baffle is removed to permit access to Class A1, A2, or A3 sources, Class B sources **shall** have restricted access for contact by craftspersons.
- 

#### 7.4.6 Class C Voltage Accessibility Requirements

Class C voltage sources are beyond the scope of this document.

### 7.5 Duration-Limited Source Requirements

#### 7.5.1 Interrupted/Tripped Sources

Interrupted/tripped voltage limits apply to ringing and other sources used for network control or testing that are normally present no more than a small portion (approximately 10%) of the time over a typical day.

**R7-17 [64]**, **R7-18 [65]**, and **R7-19 [66]** are applicable to interrupted/tripped voltage sources.

- 
- R7-17 [64]** Interrupted/tripped voltages **shall** be less than 300 V peak-to-peak and less than 200 V peak-to-ground as measured across a resistive termination of at least one MΩ.

**R7-18 [65]** The voltage **shall** be interrupted to create idle intervals of at least 1 second (continuous) duration, each separated by no more than 5 seconds. During the idle intervals, the voltage to ground **shall not** exceed Class A2 voltage limits.

**R7-19 [66]** Interrupted/tripped voltage sources **shall** include a series current-sensitive tripping device in the current lead that will trip the voltage as shown in [Figure 7-5](#) and/or, provide a voltage to ground (“monitoring” voltage) on the tip or ring conductor with a magnitude of at least 19 V peak (but not to exceed the Class A2 limits) when the interrupted voltage is not present (idle interval). Tripping devices and/or “monitoring” voltages **shall** be incorporated in the equipment, depending on the current flow through specified resistances connected between the interrupted/tripped source and ground as follows:

- a. If the current through a 500-Ω and greater resistor does not exceed 100 mA peak-to-peak, neither a tripping device nor a “monitoring” voltage is required.
- b. If the current through a 500-Ω and greater resistor exceeds 100 mA peak-to-peak but does not exceed this value of current with a 1500-Ω and greater resistor, the interrupted/tripped source **shall** include either a tripping device that meets the operating characteristics shown in [Figure 7-5](#) for a resistance of 500 Ω and greater, or a “monitoring” voltage.
- c. If the current through a 1500-Ω and greater resistor exceeds 100 mA peak-to-peak, the interrupted source **shall** include a tripping device. If the tripping device meets the operating characteristics shown in [Figure 7-5](#) for a resistance of 500 Ω and greater, then no “monitoring” voltage is required. If the tripping device only meets the operating characteristics shown in [Figure 7-5](#) for a resistor of 1500 Ω and greater, then the interrupted source **shall** also include a “monitoring” voltage.

---

In a, b, and c above, it is intended that the criteria be met at the minimum resistance (500 or 1500 Ω, as appropriate) and for any greater resistance that, because of any nonlinearity in the source or tripping device, may result in higher currents.

Interrupted or tripped sources that meet the criteria of this document are considered as Class A2 voltages for the purpose of accessibility.

---

**R7-20 [145]** Substantiating data provided by an NRTL for testing interrupted/tripped voltages as part of a successfully completed listing program, is acceptable as an indication of compliance with the criteria of [Section 7.5.1](#). An example of an acceptable listing standard is UL60950-1,<sup>[33]</sup> Method B as described in Annex M.3.

---

#### 7.5.1.1 Ring-Trip Test Procedure

A generalized case will be described for a switching-system line card. Ringing is generally applied by the line card to the ring lead of the tip and ring conductor pair. The ring-trip circuit or device is also generally located in the ring lead path on the line card.

The ring-trip circuit is tested for conformity to [Figure 7-5](#) by connecting resistors, one at a time, between the ring lead appearance, typically at the Main Distribution Frame (MDF), and the Central Office Ground (CO GRD). The voltage between the ring lead and central-office ground is monitored, using an oscilloscope to determine the duration — that is, the time between the application of the resistor and the tripping of ringing. A digital storage oscilloscope is especially useful for this purpose. The peak-to-peak current is determined as the quotient of the peak-to-peak ringing voltage and the resistor value.

Resistor values of 500, 800, 1000, 1200, 1500, 1800, 2000, 2500, 3000, and 3500  $\Omega$  may be used. The 500- and 1500- $\Omega$  resistors are exact (1% tolerance); other resistor values are approximate. Additional resistor values should be used if nonlinearities in the EUT may result in higher currents or longer tripping times for these values. Each data point — that is, the peak-to-peak current in milliamperes and corresponding duration in seconds — is plotted on [Figure 7-5](#). All data points shall fall on or below the curve of [Figure 7-5](#).

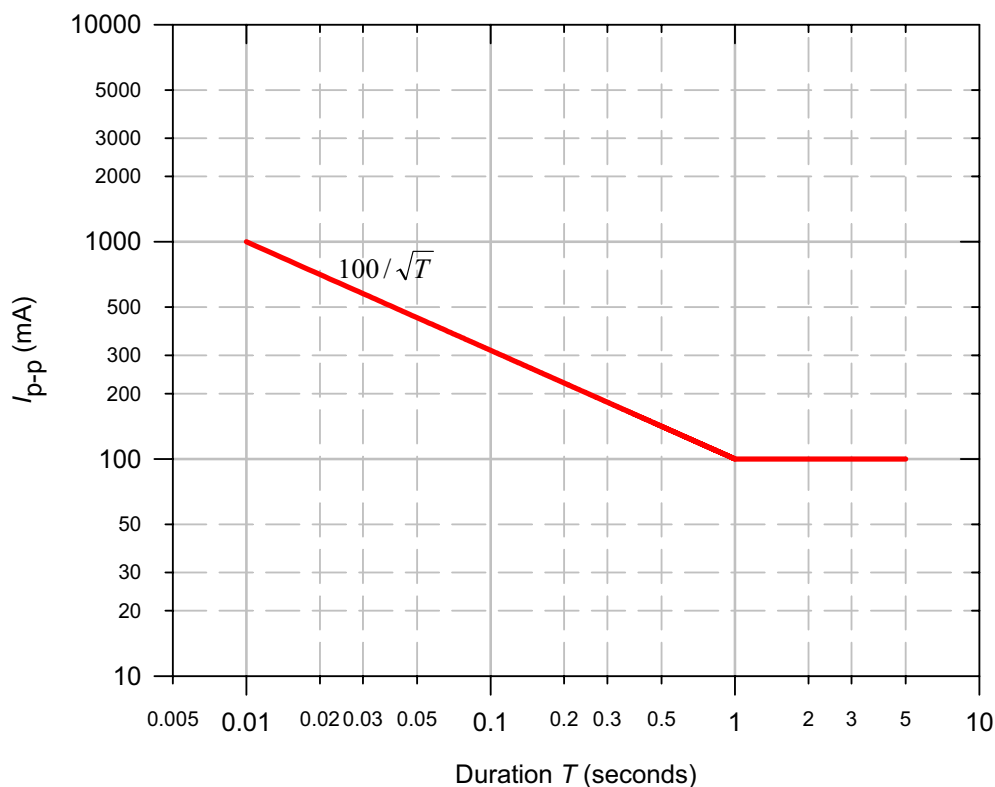
## 7.5.2 Transient Sources

---

**R7-21 [67]** The peak voltage of a transient source may exceed 200 V peak, but **shall not** exceed its intended continuous or duration-limited classification limit for longer than 0.01 s. The transient source **shall** deliver no more than 2 joules into a 500- $\Omega$  resistive load during the 0.01 s transient interval.

---

**Figure 7-5** Interrupted/Tripped Criterion Defining the Duration for Which a Current of a Given Magnitude Is Allowed to Persist



## 7.6 Power Limitation Requirement

**R7-22 [68]** Sources that may be applied to communication wiring **shall** have a functional design rated output (power rating) not greater than 100 VA and a current rating not greater than  $100/V_{max}$  where  $V_{max}$  is the maximum output voltage regardless of load with rated input applied. The output power rating is the maximum power that the source is designed to supply over the communications wiring to any intended load circuit under normal operating conditions, including power dissipated in the cabling. Paralleling of power sources over multiple communications wires for the purpose of delivering power in excess of 100 VA to a single load circuit **shall not** be permitted. This power limitation is not intended to apply to the CO power and battery plant.

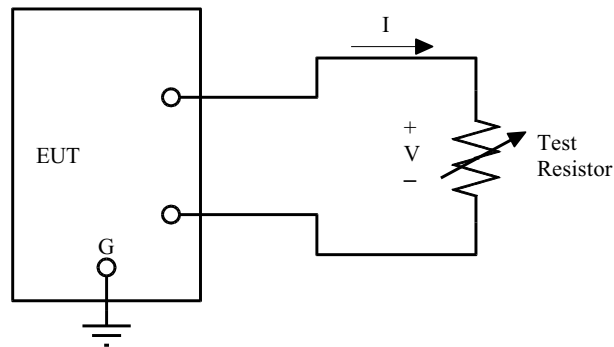
This power limitation is not intended to preclude the use of several individual 100 VA power sources, each of which feeds a separate set of communications lines to a separate remote load circuit.



The maximum continuous current from sources that may be applied to communication wiring under normal conditions **shall** be consistent with its power rating, but **shall not** exceed 1.3 A unless the ampacity of the network wiring and current rating of network connectors and other network components is specified at a higher value and controlled. The maximum output current ( $I_{max}$ ) under overload and fault conditions **shall not** exceed  $150/V_{max}$  or 2.4 A, whichever is less.

The maximum output voltage and current ( $V_{max}$  and  $I_{max}$ ) are to be determined from the volt-ampere characteristics of the power source. The volt-ampere characteristics are determined by connecting a variable resistor (or a set of resistors) across the output terminals. Figure 7-6 illustrates the test circuit. Output voltage and current are measured for various resistance values between 1 M $\Omega$  and a short circuit of less than 15 m $\Omega$ . For each resistance, the voltage and current value are measured after 1 second of operation with any overcurrent protection bypassed.

**Figure 7-6** Test Circuit for Determining Volt-Amperes Characteristics



## 7.7 Leakage Currents From Exposed Surfaces

### 7.7.1 General Considerations

Surfaces of equipment and of interconnecting cords or cables, with any removable housing or cover in place and with interconnecting cords or cables connected, that may be contacted with the accessibility probe shown in Figure 7-4 where dimension “A” is 3.54 cm (1.38 in) are considered exposed surfaces. Exposed surfaces are to meet the required leakage current limits under normal conditions of applied voltages and for all modes of operation of the equipment.

An exception to exposed surfaces that are to meet required leakage current limits are those portions of the electrical network that should be accessible to personnel and trained personnel for normal operations (such as terminals, connectors, and conductors), provided the exempt exposures are exposed only to personnel and trained personnel. The voltages, currents, and power associated with these exempt exposures are covered by the continuous and duration-limited requirements described in Section 7.4 and Section 7.5, and the power limitations described in Section 7.6.

## 7.7.2 Leakage Current Requirements

Leakage currents that are permitted from exposed surfaces with respect to ground are a function of the surface area that may be contacted — that is, small-area or large-area contact. Requirements are also placed on leakage currents between any two exposed surfaces of the contiguous equipment.

For the purpose of determining compliance with the leakage current requirements, a conducting surface or metal part is considered grounded only if it is grounded intentionally in accordance with National Electrical Code<sup>[49]</sup>, Article 250. If the conducting surface or metal part is not securely grounded by design and construction, it is to be considered ungrounded. Compliance is then determined with any such connection removed.

A frequency-weighted equivalent current is used for ac voltages. The equivalent ac leakage current,  $I_{ie}$ , of a sinusoidal waveform of peak amplitude  $I$  is

$$\begin{aligned}
 I_{ie} &= [1 + (f/300)^2]^{-1/2} I && \text{if } 0 < f \leq 10 \text{ kHz} \\
 I_{ie} &= 0.03I && \text{if } 10 \text{ kHz} < f
 \end{aligned}
 \tag{7-7}$$

where  $f$  is the frequency in Hz.

Where ac signals are composed of more than one frequency, the peak of the sum of equivalent leakage currents is the relevant parameter.

### 7.7.2.1 Leakage Current Requirements for Large Area Contact

**R7-23 [69]** The current from any 100 cm<sup>2</sup> (15.50 in.<sup>2</sup>) area or the entire area, whichever is smaller, of exposed surface (excluding grounded metal surfaces) measured in a 1500-Ω resistor connected between the area and ground **shall** be less than 0.3 mA peak.

### 7.7.2.2 Leakage Current Requirements for Small Area Contact

**R7-24 [70]** The current from any 1 cm<sup>2</sup> (0.16 in.<sup>2</sup>) area of exposed surface (excluding grounded metal surfaces) measured in a 10,000-Ω resistor connected between the area and ground **shall** be less than 0.15 mA peak.

### 7.7.2.3 Leakage Current Between Surfaces of Equipment

**R7-25 [71]** The current measured in a 10,000-Ω resistor connected between any two areas of exposed surface (excluding grounded metal surfaces) of 1 cm<sup>2</sup> (0.16 in.<sup>2</sup>) each **shall** be less than 0.15 mA peak.

## 8 Corrosion

This section provides criteria for voltages applied to OSP conductors for minimizing corrosion.

### 8.1 Polarity of DC Voltages Applied to OSP Cabling

This section does not apply to equipment in networks that require voltages above 200 V dc between conductors for proper operation. An example of a network circuit requiring higher voltages is a network that provides remote powering (see [Section 7.6](#)).

---

**O8-1 [72]** It is desirable that equipment ports that interface with the OSP **should** apply only DC voltages that are zero or negative in polarity with respect to ground to minimize stray current corrosion in OSP cables and equipment where water intrusion may occur.

---

### 8.2 Magnitude of DC Voltages Applied to OSP Cabling

This section does not apply to equipment in networks that require voltages above 56.7 V dc for proper operation. An example of a network circuit requiring higher voltages, is a network that provides remote powering (see [Section 7.6](#)).

The CO battery, or other dc voltages applied to telecommunications conductors, causes leakage currents and corrosion on primary protectors and on faceplates with binding posts in humid environments. A potential difference between tip and ring (tip/ring and tip1/ring1 in 4-wire circuits) or either conductor and ground can cause corrosion and leakage currents that are independent of the type of cable used.

---

**O8-2 [73]** It is desirable that continuous DC voltage potentials between telecommunications conductors or between conductors and ground **should** have a magnitude of less than 56.7 V.

---



## 9 Bonding and Grounding

### 9.1 Scope

This section provides requirements for bonding and grounding of network telecommunication equipment and guidance for their usage. The main goals of bonding and grounding are the following:

- Provide potential equalization to reduce voltage differences that might harm people, or damage equipment or the facility
- Provide a reliable low-impedance return path for fault currents to enable rapid operation of overcurrent devices
- Help avert equipment damage from unwanted energy resulting from lightning strokes, lightning-caused surges on metallic communication conductors, or surges on metallic communication conductors caused by commercial ac power
- Help avoid interference and malfunction of equipment.

Section 9 provides requirements for bonding and grounding of equipment at the following locations:

- Network Telecommunications Facilities,
- Subscriber Premises, or
- OSP.

**NOTE:** Additional bonding and grounding requirements may apply to equipment and equipment enclosures installed in the OSP as described in relevant Telcordia Generic Requirements.

In Section 9, a network telecommunication facility is defined as a CO, EEE, Electronic Equipment Cabinet (EEC), or other telecommunications space that serves a similar function.

**NOTE:** [Appendix D](#) provides definitions of EEE and EEC.

Factors, such as the location where equipment is intended to be installed, the type of equipment powering, and equipment construction, determine the applicability of the requirements in this section.

### 9.2 General Requirements Principles

---

**R9-1 [74]** This requirement has been deleted.

---

The intent of bonding and grounding systems in telecommunication facilities and equipment is to shield people and equipment from the adverse effects of electromagnetic energy. Practically, bonding and grounding has the following objectives:

- **Personnel Safety** — The bonding and grounding system helps to reduce potential differences within and between metallic frames and structures that could create a personnel shock hazard from lightning or fault currents.
- **Equipment and Distribution Circuit Protection** — The bonding and grounding system helps to provide fault current paths of sufficiently low impedance and adequate current-carrying capability so that overcurrent protective devices can prevent electrical fires and damage to equipment conductors, conductor insulation, and any component of the fault current path.
- **Equipment Operation** — The bonding and grounding system helps to mitigate the effect of electrical disturbances (such as power faults or lightning strokes) on equipment operation. The system helps to equalize potentials throughout the bonding network for the communication circuits connected to it. It helps to provide a reliable connection to earth for earth-return signaling circuits.
- **Noise Reduction** — The bonding and grounding system helps to mitigate electrical interference by maintaining low-impedance paths between ground points throughout the communication system. It helps to prevent or minimize the injection of noise currents into isolated bonding networks.
- **Reliability** — The bonding and grounding system is to consist of wiring, buses, connectors, and connections that resist loosening and deterioration, and require minimal maintenance for the lifetime of the installation.

The specific criteria of Section 9 are intended to help achieve these objectives.

---

**R9-2 [75]** A bonding and grounding system **shall** employ electrical conducting paths intentionally provided for the purpose. Bonds within and between frames, cabinets, and other metallic structures **shall** be specifically provided. The bonding and grounding system **shall not** depend on incidental paths such as those existing between chassis and frames, cable rack sections, and building steel sections.

Conductive objects with accessible surface areas of less than 100 mm<sup>2</sup> that are not likely to become energized are not required to be grounded.

---

### 9.3 Equipment Grounding Systems

The requirements of this section apply to equipment intended for installation in network telecommunication facilities. The requirements of this section do not apply to self-contained equipment intended mainly for installation in locations other than network telecommunication facilities.

---

**R9-3 [76]** The equipment documentation and installation instructions **shall** indicate whether the EUT is suitable for installation as part of the Common Bonding Network (CBN) or an Isolated Bonding Network (IBN) or both.

---

### 9.3.1 Common Bonding Network (CBN)

Building steel, water pipes, cable racks, vertical and horizontal equalizer conductors, bonding conductors, and electrical metallic raceways form the CBN within a building when bonded together by deliberate and incidental connections. The CBN is also connected to the building's grounding electrode system. Connections to the CBN are usually made from equipment frames to reduce voltage differences to acceptable levels when current flows through these frames, either during fault occurrences in the ac or dc power systems, or when lightning strikes.

**NOTE:** GR-295-CORE<sup>[1]</sup> and early versions of the generic criteria in GR-1089-CORE refer to the CBN as the Integrated Ground Plane. GR-295-CORE and ITU-T Recommendation K.27<sup>[50]</sup> refers to equipment that have multiple connections to the CBN as part of a “mesh bonding network (mesh-BN).” The term CBN as used here will include such mesh bonding networks.

---

**R9-4 [116]** Equipment having multiple intentional or incidental connections to the CBN (bonded as part of a CBN) and that has previously been required to be bonded in an IBN **shall** comply to the requirement of [Section 9.12](#).

---

The tests in [Section 9.12](#) are required for equipment that has traditionally been installed in an IBN. In addition, suppliers can elect to apply these tests to high-speed equipment such as DSLAMs, COTs, and optical multiplexers installed as part of the CBN.

### 9.3.2 Isolated Bonding Network (IBN)

An IBN is a set of interconnected equipment frames that is intentionally grounded by a single-point connection to the CBN of the building. This IBN, taken as a conductive unit with all of its metallic surfaces and grounding conductors bonded together, is insulated from contact with any other grounded metalwork in the building. During external fault occurrences in the ac or dc power systems and when lightning current flows in the building, none of these currents can flow in the IBN because of the single-point connection.

**NOTE:** GR-295-CORE<sup>[1]</sup> and early versions of the generic criteria in GR-1089-CORE refer to the IBN as an Isolated Ground Plane.

IBN requirements have traditionally been applied to electronic Stored Program Control Switching Systems (SPCSS) that typically provide local and intraLATA (Local Access and Transport Area) telecommunications services and access to interLATA and international carriers. Generic requirements for IBNs for SPCSS frames and associated power supplies are contained in GR-295-CORE.<sup>[1]</sup>

## 9.4 AC Equipment Grounding

This section describes the requirements for the equipment grounding conductors in AC distribution within a frame, bay or network facility up to the point where equipment shelves are connected. AC grounding requirements for equipment shelves are covered by the criteria in [Section 9.5](#) and [Section 9.6](#).

---

**R9-5 [77]** Requirements of Article 250 of the most recent edition of the National Electrical Code (NEC), ANSI/NFPA 70,<sup>[49]</sup> **shall** be met except where superseded by local electrical codes. Also, in network telecommunication facilities, all AC-operated equipment and AC system components **shall** be grounded as follows.

- All ac feeder and branch-circuit conductors **shall** be run in metallic raceway from source to load. The raceway **shall** be joined to form an electrically continuous equipment grounding conductor.
  - An Alternating Current Equipment Grounding (ACEG) conductor, enclosed in the same raceway with the phase conductors, **shall** be provided for circuits distributing ac power. This conductor **shall** be solid or stranded, insulated, covered, or bare, and when covered or insulated, it **shall** be identified by a continuous green color or a continuous green color with one or more yellow stripes. All ACEG conductors **shall** be bonded to each junction box that they pass through and **shall** terminate on the enclosure of the equipment being powered or on the junction box containing the load being served.
  - ACEG conductors (sometimes referred to as the “green wire” ground) **shall** be made of the same metal that is used for their associated phase and neutral conductors (copper or aluminum). The size of the ACEG **shall** be in accordance with Section 250.122 of the most recent issue of the NEC.
  - Armored cable containing a bare bonding strip to decrease sheath resistance **shall not** be used as an equipment grounding conductor. Armored cable may be used if a separate equipment grounding conductor is contained within the armor.
  - All ac distribution raceways and enclosed ACEG conductors that enter IBN equipment area **shall** be bonded to the main ground bus within the ground window associated with that IBN.
- 

## 9.5 Communication Equipment Grounding

This section provides requirements for grounding of equipment at various locations as specified in the following section.

---

**R9-6 [213]** The equipment documentation and installation instructions **shall** indicate whether the EUT is suitable for installation in one or more of the following:

- Network Telecommunication Facilities
  - Locations where the NEC applies
  - OSP.
-



### 9.5.1 Network Telecommunication Facilities

**R9-7 [78]** Frames, cabinets, and metallic enclosures of communication equipment **shall** be grounded as follows.

- A Central Office Ground (CO GRD) system **shall** be provided in each CO according to practices specified by the telecommunications service provider. Similarly, in CEVs, EEEs, and similar facilities, an interior equipment grounding system **shall** be provided according to practices specified by the telecommunications service provider.
- The CO GRD system, or interior equipment grounding system, **shall** be connected to a building grounding electrode system approved by the telecommunications service provider.
- Distributing frames and protector frames **shall** be grounded as part of the CBN.
- Each frame, cabinet, or similar metallic communication equipment enclosure or supporting assembly **shall** provide a means for attaching a connector to be used for making the connection to the CO GRD system or interior equipment grounding system. The location for the attaching means **shall** be readily accessible to the installer. The connector **shall** be installed in accordance with the requirements described in [Section 9.9.2](#) and [Section 9.9.3](#).

**NOTE:** Requirements for interfacing electronic Stored Program Control Switching Systems with the CO GRD system and with CO power systems are contained in GR-295-CORE.<sup>[1]</sup>

- To minimize possible differences of potential, all CBN conductive elements located within 6 feet of an IBN **shall** be bonded to the IBN main ground bus within the ground window. Such elements include, but are not limited to
  - Metallic stands and desks
  - Electromechanical equipment frames
  - Ironwork
  - Lighting fixtures that are not part of the IBN
  - Air ducts.

### 9.5.2 Locations Where the NEC Applies

This section provides requirements for grounding and bonding of equipment intended to be installed in accordance with NEC Articles 800 and 830. The requirements for Listing of equipment are given in [Section 7.2](#).

**R9-8 [146]** At locations where applicable, requirements of the most recent edition of the NEC, Article 800 or Article 830, as applicable, covering listing requirements for equipment intended to be electrically connected to a telecommunications network **shall** be met. Equipment grounding requirements as specified in the equipment listing **shall** be met.

### 9.5.3 Outside Plant

This section provides requirements for grounding of outer enclosures of equipment, such as cabinets, coaxial amplifier cases, etc., installed in the OSP. Section 9.6 provides requirements for bonding and grounding of equipment units (e.g., equipment shelves). Section 9.5.1 provides for bonding and grounding of frames, cabinets, and metallic enclosures of communication equipment installed inside the outer enclosure.

- 
- R9-9 [147]** For network telecommunications equipment installed in the OSP, an attachment means **shall** be available for connecting to the metallic equipment enclosure or to non-current-carrying metallic equipment frames, a No. 6 AWG copper grounding conductor from an approved grounding electrode. Non-current-carrying metallic parts of network equipment installed in the OSP **shall** be grounded in accordance with Rule 99 of the most recent edition of the National Electrical Safety Code (NESC), ANSI/IEEE C2.<sup>[51]</sup>
- 

## 9.6 Equipment Unit Bonding and Grounding

This section provides requirements for bonding and grounding of equipment units (e.g., equipment shelves) mounted in frames, cabinets or other enclosures. If such units are mounted independently, their grounding is covered by Section 9.5. The bonding and grounding requirements for the unit assemblies are covered by Section 9.7.

- 
- R9-10 [79]** An electrical conducting path **shall** exist between a unit's chassis and the metalwork of the enclosure in which it is mounted or a grounding conductor. Electrical continuity **shall** be provided by at least one of the following methods:
- Separate conductor(s) between the unit's chassis and the enclosure metalwork or a nearby point on the CO GRD system or the interior equipment grounding system.
    - For units installed in an IBN, the requirements of GR-295-CORE<sup>[1]</sup> apply.
  - The use of thread-forming type unit mounting screws that remove any paint or nonconductive coatings and establish metal-to-metal contact. Suppliers' documentation **shall** require that paint and other nonconductive coatings be removed on the surfaces between the mounting hardware and the framework or cabinet. The documentation **shall** also require the surfaces to be cleaned and an anti-oxidant applied before being joined.

This path **shall** be of sufficiently low impedance to facilitate the operation of any circuit overcurrent protection and it **shall** be capable of safely conducting any fault current likely to be imposed. This includes fault current from sources within the unit, such as dc-to-dc converters. Tests **shall** be performed in accordance with the requirements in Section 9.10.1 and Section 9.10.2.

---

## 9.7 Provisions for Equipment Unit Assembly Bonding and Grounding

This section contains requirements for the provisions for the bonding and grounding of equipment unit assemblies (shelves, circuit modules, back planes, circuit boards, etc.) in Network Telecommunication Facilities. [Section 9.5.2](#) contains the bonding and grounding requirements for network equipment located where the NEC applies.

**R9-11 [148]** Unit assemblies located in a network facility **shall** have an electrical conducting path provided on the assembly for adequately bonding exposed conductive surfaces and fault current carrying paths to a suitable grounding means. This suitable grounding means may be the supporting metalwork of the chassis, frame or cabinet or a ground terminal that can be grounded in accordance with [Section 9.6](#) or [Section 9.5](#).

**NOTE:** UL 60950-1<sup>[33]</sup> and IEC 60950-1 use the term “protective earthing terminal” to refer to such suitable grounding means.

Electrical continuity **shall** be provided by the following method.

- Exposed conductive surfaces, (e.g., conductive faceplates of circuit packs) must be intentionally bonded to the grounding means of the unit. The bonding of exposed conductive surfaces to the grounding means must have a sufficiently low impedance (<100 mΩ) to adequately carry fault currents and prevent unsafe voltage potentials.
  - In particular, doors or covers on equipment that are intended to remain attached to the equipment assemblies during maintenance shall be bonded with an appropriate gauge stranded wire or copper braid wire and attached with anti-rotation connection methods (e.g., barriers, lockwashers).
- The conducting path from the exposed conductive surfaces **shall** be of sufficiently low impedance (<100 mΩ) to facilitate the operation of any circuit overcurrent protection and it **shall** be capable of safely conducting any fault current likely to be imposed. This includes fault currents from sources within the equipment, such as dc-dc converters. Tests **shall** be performed in accordance with the requirements in [Section 9.10.1](#) and [Section 9.10.2](#).
- Exposed surfaces for shielded or coaxial cable connectors are not required to be solidly bonded under the following conditions:
  - The connector belongs to the receive port of transmission circuit that has a defined transmit and receive end
  - Manufacturer’s instructions state that the transmit end of the cable must be grounded
  - The circuit does not contain sources at Class A3 or higher as defined in Section 7
  - The connector is not likely to become energized with other sources within the equipment.

Exposed surfaces for shielded or coaxial cable connectors for the transmit end or where the transmit or receive ends cannot be identified shall be bonded as required in this section.

**NOTE:** Painted surfaces are considered conductive in terms of accessibility as thickness, porosity, and dielectric strength of paint are not controlled. Painted surfaces are not considered conductive for electrical connections.

**NOTE:** Conductive objects with accessible surface areas of less than 100 mm<sup>2</sup> that are not likely to become energized, are not required to be grounded.

**NOTE:** Extractor tabs or faceplate latches need not be grounded provided an investigation determines it is unlikely that they could become energized as a result of normal operation or a reasonable fault.

### 9.7.1 Connectors and Connection Methods for Equipment Unit Assemblies

**R9-12 [149]** Connectors and connection methods for bonding and grounding equipment unit assemblies **shall** meet the following requirements:

- Grounding connectors on equipment unit assemblies **shall be** Listed or Recognized and **shall** be compatible with bonding and grounding conductors specified in Section 9.9.1. Ground studs or other integrated ground connection means are acceptable on equipment provided the equipment is listed and is capable of terminating a grounding conductor in a manner consistent with this section.
- Two-hole connectors **shall not** be required on smaller subassemblies (e.g., circuit pack shelves and magazines) contained within cabinets, frames, and racks where anti-rotation devices (e.g., barriers, lockwashers) are used or where there is minimal possibility of loosening from rotation during installation and maintenance activity.
- A soldering lug, screwless (push-in wire) connector, or a quick-connect or other friction-fit connector **shall not** be used to terminate a bonding or grounding conductor to the suitable grounding means.
- Connection devices or fittings for the suitable grounding means that depend solely on solder **shall not** be used.
- Multiple bonding or grounding connectors **shall not** be secured by the same bolt and **shall not** need to be removed to perform other service or installation procedures. It is permissible to connect other bonding or grounding conductors to a grounding connector provided a reliable bond between the connector and the equipment is not disturbed during installation, service or maintenance.

### 9.7.2 Bonding of Circuit Packs

**R9-13 [150]** Circuit packs/modules that plug into equipment assemblies and that contain parts that require grounding **shall** be bonded to the host system's grounding means

either by intentional and reliable metal-to-metal contact or by wires, PCB traces, appropriate backplane connectors or similar means.

## 9.8 DC Power System Grounding

### 9.8.1 Centralized Power Sources

**R9-14 [80]** In network telecommunication facilities, all centralized dc power systems (those not embedded within the equipment being powered) **shall** be grounded to the CO GRD system, to the facility's interior equipment grounding system or both. The required grounding **shall** consist of connecting the return side (usually the positive terminal) of the centralized power source to the CO GRD system, the interior equipment grounding system or both. For power sources supplying IBN loads such as electronic SPCSS, the return side of the power source **shall** be grounded in accordance with the requirements of GR-295-CORE.<sup>[1]</sup>

### 9.8.2 Embedded Power Sources

An embedded dc power source is a source (rated >20 VA) that is contained within a unit of network equipment that provides output power to units of the same system or other equipment within a network.

- R9-15 [81]** Embedded dc power sources **shall** be grounded except as noted in one of the following clauses:
- A. Embedded dc power sources with a rated output of 150 VA or less and containing output power limiting (e.g., “fold-back” output V-I characteristic), and conforming to the short-circuit requirements of [Section 9.10.1](#), need not be grounded. Where multiple sources have parallel outputs, the rated output is considered to be the sum of the rated outputs of all individual sources that are in parallel.
  - B. Embedded dc power sources with outputs rated greater than 150 VA in products intended to comply with the requirements IEEE Std. 802.3af-2003<sup>[52]</sup> shall not be grounded provided they comply with all of the following:
    1. The embedded source does not supply power to any loads outside the equipment enclosure without additional power limitation. If power derived from this embedded power source is distributed outside the enclosure, it shall comply with the power limitation requirements of [Section 7.6](#).
    2. The embedded source output is connected to ground through a capacitance or provided with a grounded screen between input and output.
    3. The source provides output power limiting (e.g., “fold-back” output V-I characteristic) and conforms to the short-circuit requirements of [Section 9.10.1](#).

- C. Embedded dc power sources with outputs rated greater than 150 VA shall not be grounded provided they comply with all of the following:
1. The embedded source supplies power greater than 150 VA solely to equipment shelf, circuit packs, or module where it is mounted. Any power supplied to loads outside this equipment shelf, circuit packs, or module shall be limited to 150 VA for any non-capacitive load measured after one second of operation with any overcurrent protection bypassed.
  2. The source provides output power limiting (e.g., “fold-back” output V-I characteristic) and conforms to the short-circuit requirements of [Section 9.10.1](#).

The required grounding **shall** consist of connecting the output terminal that is designated to be grounded to one of the following:

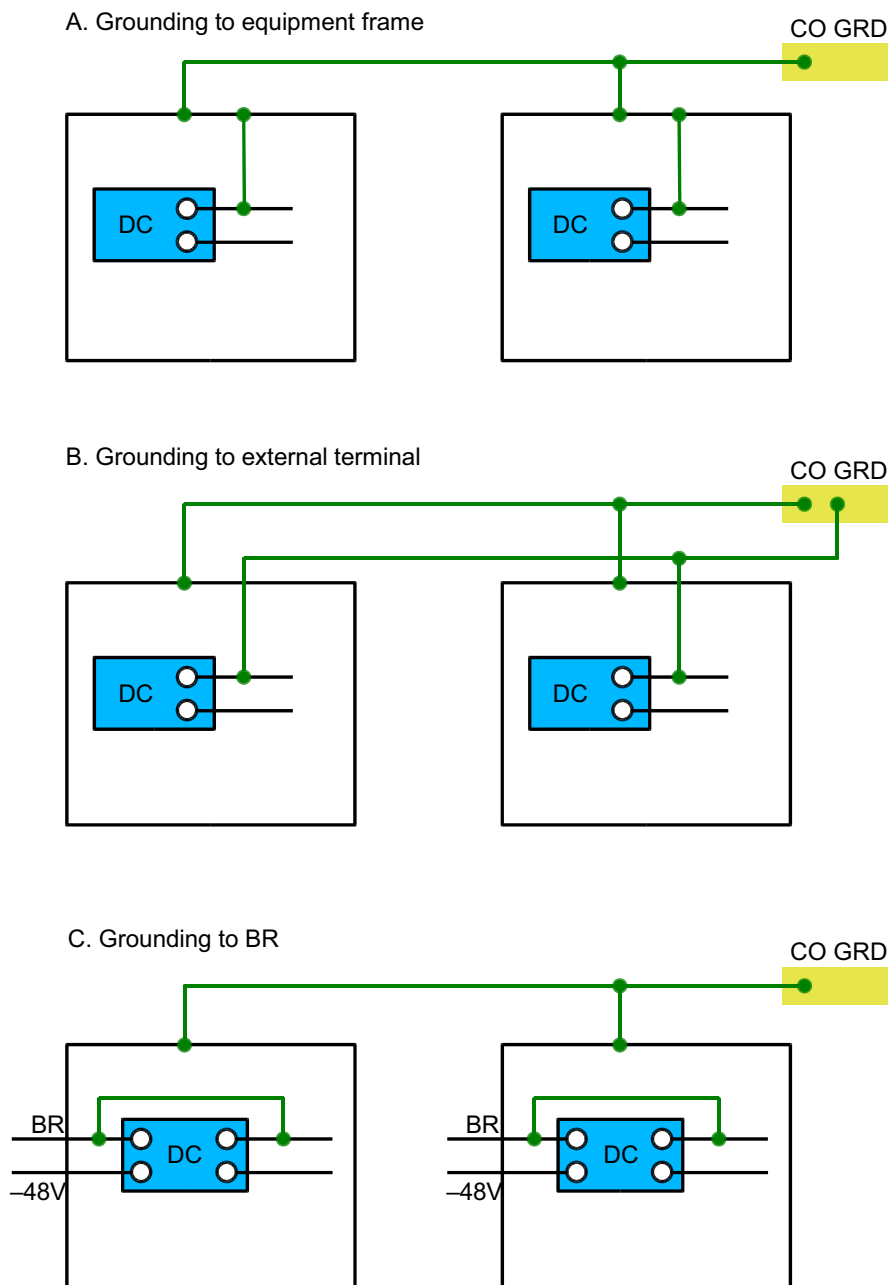
1. The equipment frame (see [Figure 9-1A](#)).
2. A ground bus, backplane layer, or other connection means that is bonded to the equipment frame.
3. A designated terminal that may be located outside of the equipment frame.
  - This designated terminal **shall** be connected to the CO GRD system and bonded to each frame that it serves. The bonding to the frames could be by a direct connection or by connecting to a CO GRD terminal used as a bonding terminal for the frames. (See [Figure 9-1B](#)).
4. To the BR conductor in the EUT directly or indirectly (See [Figure 9-1C](#)).

To the greatest extent practicable, the grounding location should be at the immediate output of the power source. Grounding at the load or between the immediate output and the load is permitted as necessary.

Embedded power sources located within IBN equipment frames **shall** be grounded in accordance with GR-295-CORE.<sup>[1]</sup>

---

**Figure 9-1** Illustration of Three Options for Grounding an Output of Embedded DC Power Source



### 9.8.3 Bonding of Battery Return (BR) Input Terminals

**R9-16 [151]** If the equipment has a dc power port, the equipment documentation and installation instructions **shall** specify the treatment of the Battery Return (BR) input terminals as one of the following

- Isolated DC return (DC-I),
- Common DC return (DC-C), or
- Either DC-C or DC-I.

In the DC-I configuration, the DC return terminal or conductor is not connected to the equipment frame or the grounding means of the equipment. In the DC-C configuration, the BR terminal or conductor is connected to the equipment frame or to the grounding means of the equipment.

Equipment in a DC-I configuration **shall** not have any solid connections within the equipment between the BR and frame, or between the BR and the grounding means of the equipment. Filters **shall** be permitted to be installed between the DC input and frame. In this case, the total current conducted by all filters of the equipment unit (see [Section 9.6](#)) into the frame and the grounding means **shall not** exceed  $X \times 3.5$  milliamperes (DC or 60-Hz AC), where X is the total number of dc power terminals (-48V and BR). This current **shall** be measured by isolating the EUT from ground (except the grounding conductor), and measuring the current in the grounding conductor with the EUT fully powered. The BR of the power source **shall** be connected to ground during the measurements.

Tests for all the criteria of this GR **shall** be performed with the equipment in the specified DC-return configuration. For the equipment compatible with the DC-C or DC-I configuration, the conducted immunity tests on the DC power leads **shall** be done in both configurations. For other tests in this GR, the configuration of lowest impedance **shall** be used. Also see [Section 3.4.4.8.5](#), [Section 3.5.5.3.5](#), and [Section 4.6.2.3](#). During the performance of the tests, the grounding and bonding conductor for the EUT and the associated power source **shall not** be any longer than necessary and **shall** avoid unnecessary bends and loops.

**R9-17 [152]** In the DC-C configuration, the ampacity of the conductor connecting the equipment frame to the BR conductor **shall** be equal to or greater than the ampacity of the associated BR conductor.

## 9.9 Bonding and Grounding Conductor and Connection Requirements

This section provides requirements for bonding and grounding conductors and connections in general. However, the requirements of this section are not intended to apply to a unit's chassis or circuit packs. See [Section 9.7.1](#) for chassis and [Section 9.7.2](#) for circuit packs.



### 9.9.1 Bonding and Grounding Conductors

**R9-18 [82]** Bonding and grounding conductors **shall** be of sufficiently low impedance to facilitate the operation of circuit overcurrent protection devices and **shall** be capable of safely conducting any fault current likely to be imposed. Bonding and grounding conductors **shall** be made of copper (tinned or untinned). Aluminum conductors **shall not** be used. Conductors made of wire, bus bar, or braided strap are acceptable. Conductors can be either insulated or uninsulated.

### 9.9.2 Connections

**R9-19 [83]** Because of different characteristics of copper and aluminum, connection devices **shall** be properly installed and used. Conductors of dissimilar metals **shall not** be intermixed in a terminal or splicing connector where physical contact occurs between dissimilar conductors (such as copper and aluminum, or copper and copper-clad aluminum), unless the device is suitable for the purpose and conditions of use. Materials such as fluxes, inhibitors, and compounds, where employed, **shall** be suitable for the use, and **shall** be of a type that will not adversely affect the conductors, installation, or equipment.

**R9-20 [84]** Bare conductors **shall** be coated with an appropriate antioxidant compound before crimp connections are made. All unplated connectors, braided strap, and bus bars **shall** be brought to a bright finish and then coated with an antioxidant before they are connected. Tinned, solder-plated, or silver-plated connectors and other plated connection surfaces do not have to be prepared in this manner, but they **shall** be clean and free of contaminants. All raceway fittings **shall** be tightened to provide a permanent low-impedance path.

**R9-21 [85]** Multiple connectors **shall not** be secured by the same bolt assemblies.

**R9-22 [86]** Unplated connection surfaces that are to be intentionally joined to form a bonding or grounding path **shall** be brought to a bright finish and then coated with an antioxidant before they are joined (electrically connected).

**R9-23 [87]** Listed fastening hardware **shall** be compatible with the materials being joined and **shall** preclude loosening, deterioration, and electrochemical corrosion of the hardware and joined materials.

**R9-24 [88]** Nonconductive coatings (such as paint, lacquer, and enamel) on equipment to be bonded or grounded **shall** be removed from threads and other contact surfaces to assure electrical continuity.

The use of thread-forming type unit mounting screws that remove any paint or nonconductive coatings and establish metal-to-metal contact as allowed in [Section 9.8](#) is an acceptable means to meet this requirement.

### 9.9.3 Connectors

- R9-25 [89]** Only listed two-hole compression-type connectors **shall** be used in making connections to flat surfaces (such as bus bars, frames, racks, or cabinets). Torquing and bolt assembly requirements for securing the connector **shall** be as specified by the connector supplier.
- R9-26 [90]** Grounding and bonding conductors **shall** be connected (including tap connections) by exothermic welding or listed compression-type connectors to the greatest extent practicable. Where exothermic welding or listed compression-type connectors cannot be used, listed pressure connectors, listed clamps, or other listed means may be used. Connection devices or fittings that depend solely on solder **shall not** be used.
- R9-27 [91]** A soldering lug, a screwless (push-in) connector, or a quick-connect or other friction-fit connector **shall not** be used to terminate a bonding or grounding conductor.

## 9.10 Short-Circuit Tests

**NOTE:** The short-circuit tests that follow are intended to be performed only on out-of-service equipment.

**NOTE:** Discrete equipment assemblies that have been listed by an NRTL generally do not need to be subjected to the short-circuit tests in [Section 9.10.1](#) and [Section 9.10.2](#), and are considered compliant with this section. Examples of acceptable listing standards are UL 1459<sup>[32]</sup> and UL 60950-1.<sup>[33]</sup> However, if the EUT has a DC or AC power source rated at >20 VA that would not be required to be tested as part of the NRTL listing program, it shall be tested as described in [Section 9.10.1](#) and [Section 9.10.2](#), as appropriate.

### 9.10.1 DC Power Sources

- R9-28 [92]** Except as noted below, at least one short-circuit test **shall** be performed on each type of dc power source having a rated power rating of greater than 20 VA associated with the network equipment. Typical types of dc supplies are rectifiers, rectifiers and associated battery, and dc-to-dc converters.

The short-circuit test need not be applied for a source consisting of a battery or a string of batteries that is not equipped with an overcurrent protective device. If the output of a rectifier or similar source is normally connected in parallel with batteries, the batteries shall be disconnected during the fault current tests on this source.

The short-circuit tests need not be applied for a source that solely provides power to a single telecommunications port if an equivalent short-circuit would be performed in accordance with [Section 4.6.5](#).

These tests **shall** verify that the fault-current path will safely conduct the fault current resulting from the short circuit, that the grounding and bonding connections can withstand the fault current, and in the case of power supplies required to be grounded (**R9-9 [147]**, **R9-10 [79]**), **shall** verify that the supplies are solidly grounded. Short circuits shall be initiated as follows:

- For ungrounded power supplies with output less than or equal to 150 VA and greater than 20 VA, the short circuit **shall** be initiated between the positive and negative output terminals. The short circuit **shall** first be initiated at the power supply output terminals, and repeated at the load if the load is remote from the power supply output terminals. Supplies that have one of its outputs connected to the BR conductor directly or indirectly are considered grounded.
- For grounded power supplies, short circuits **shall** be initiated between the ungrounded side of the source and the return conductor, and between the ungrounded side of the source and the metalwork of the enclosure. The short circuit shall first be initiated at the power supply output terminals, and repeated at the load if the load is remote from the power supply output terminals.

— Short-circuit tests for supplies grounded to the BR conductor as permitted in method 4 in **R9-15 [81]** in EUT using the DC-I configuration **shall** be performed with a resistance  $R_t$  between the dc power source and the EUT and repeated with a shortest practicable length of the BR conductor. Alternatively, instead of inserting the resistance  $R_t$  into the BR conductor, the resistance may be implemented as a length of small gauge conductor as part of the shorting mechanism used to perform the test. The resistance  $R_t$  shall be equal to  $2/I_2$ , where  $I_2$  is the L2 drain for the EUT. These short-circuit tests do not apply to supplies in equipment with DC-C configurations or supplies that are grounded using method 1, 2, or 3 in **R9-15 [81]**.

**NOTE:** GR-513-CORE<sup>[53]</sup> provides definitions and requirements for computation of List 1 (L1) and List 2 (L2) current drains.

- In addition, for power supplies grounded to the BR conductor as permitted in method 4 in **R9-15 [81]** in EUT using the DC-I configuration, two separate short circuits between the positive and negative output terminals of one or more supplies and the metalwork of the enclosure shall be initiated. The short circuit shall first be initiated at the power supply output terminals, and repeated at the load if the load is remote from the power supply output terminals. These short-circuit tests do not apply to supplies in equipment with DC-C configurations or supplies that are grounded using method 1, 2, or 3 in **R9-15 [81]**.
- For grounded power supplies > 20 VA, short circuits **shall** be initiated between the ungrounded side of the source and the return conductor, and between the ungrounded side of the source and the metalwork of the enclosure. The short circuit shall first be initiated at the power supply output terminals, and repeated at the load if the load is remote from the power supply output terminals.
- For ungrounded power supplies with output greater than 150 VA as permitted in **R9-15 [81]**, the short circuit shall be initiated between the positive and negative output terminals. In addition, two separate short circuits between the positive and negative output terminals of one or more supplies and the metalwork of the enclosure shall be initiated. The short circuit(s) shall first be initiated at the

power supply output terminals, and repeated at the load if the load is remote from the power supply output terminals.

Suggested points to initiate the short circuits are at points on the output circuit that are farthest from the source and downstream from over-current devices intended to protect equipment and wiring.

Short-circuit tests **shall** be applied to embedded dc power supplies that are mounted on (on-board) and intended to power individual circuit packs, as well as to supplies intended to power a complete shelf or rack of circuit packs. For on-board power supplies, the short circuit **shall** first be applied at the power supply output terminals, and repeated downstream (within the circuit pack) from the power supply output. A representative sample of test points shall be chosen to cover variations in wiring path lengths and affected components.

Where the architecture includes a separate power supply for an entire shelf or rack of circuit packs, the short shall first be applied at the output terminals of the power supply, and repeated at a point within the individual circuit pack(s) being powered. If there are a number of circuit pack types or configurations, then a representative sample of each type or configuration shall be tested.

For both grounded and ungrounded power supplies, conformance to this requirement **shall** be demonstrated by the following conditions.

- The EUT **shall not** become a fire, fragmentation, or electrical safety hazard as described in [Chapter 4](#).
- There **shall be no** damage to or interruption of any bonding or grounding conductor or connector required in [Section 9.5](#), [Section 9.6](#), [Section 9.7](#), and [Section 9.8](#).
- The circuit pack, module, or subassembly where the short-circuit is applied, including any power supplies within the unit assembly, need not be in full working order after the short-circuit is removed. Damage to other circuit cards, modules, and subassemblies within the unit assembly **shall not** occur. Damage to other equipment or wiring **shall not** occur. Fuse replacement is permitted.
- A power supply that supplies multiple units **shall** be restorable by operator intervention (e.g., fuse replacement) after the removal of the short-circuit, except where the short is applied upstream of the protective circuit for the power supply.

Each short circuit **shall** be applied for one minute. When the supply ceases delivering current (e.g., overcurrent protection operates) the short circuit can be removed. If after one minute, the supply continues to deliver non-negligible (>1A) current into the short circuit, the short circuit **shall** be maintained until the current ceases or for 15 minutes, whichever occurs first.

If the circuit is interrupted by the opening of a component other than a Listed or Recognized overcurrent protection device, the test **shall** be repeated twice using new components as necessary.

---

### 9.10.2 AC Power Sources

**R9-29 [93]** At least one short-circuit test **shall** be performed on each type and size of ac output supply associated with the network equipment. Supplies typically tested are dc-to-ac inverters and isolating transformers. The test **shall** determine

- Whether the fault-current path will safely conduct the fault current produced by the short circuit,
- Whether the grounding and bonding connections can withstand the fault current,
- Whether adequate short-circuit current is available to safely operate an overcurrent protective device, and whether the interrupting capacity rating of the overcurrent protective device is adequate, or
- Whether the foldback characteristics of the ac supply are adequate.

The short circuit **shall** be caused from phase to phase (if two or more phases are present), phase to neutral, and phase to grounded enclosure metalwork. Suggested test locations are at points on the output circuit that are farthest from the source.

For power supplies having output ratings of 500 VA or less, one of the following conditions must be met:

- a. Fuse or circuit breaker **shall** operate to clear the fault in 0.5 second or less, or
- b. If the power source has a foldback volt-ampere characteristic, the output current **shall** reach its minimum value with the output voltage less than or equal to 0.1 V in less than 0.5 second.

For power supplies having output ratings greater than 500 VA, one of the following conditions must be met:

- a. A fuse or circuit breaker **shall** operate to clear the fault in about 0.1 second, or
- b. If the power source has foldback Volt-Ampere characteristics, the output current **shall** reach its minimum value with the output voltage less than or equal to 0.1 V in less than 0.1 second.

Conformance with this requirement **shall** be demonstrated by the following conditions.

- The protective device **shall** operate or the foldback characteristics **shall** activate within the specified time.
- The EUT **shall not** become a fire, fragmentation, or electrical safety hazard as described in [Chapter 4](#).
- There shall be no damage to or interruption of any bonding or grounding conductor or connector required in [Section 9.4](#), [Section 9.5](#), [Section 9.6](#), [Section 9.7](#), and [Section 9.8](#).
- The circuit pack, module, or subassembly where the short-circuit is applied, including any power supplies within the unit assembly, need not be in full working order after the short-circuit is removed. Damage to other circuit cards,

modules, and subassemblies within the unit assembly **shall not** occur. Damage to other equipment or wiring **shall not** occur. Fuse replacement is permitted.

- A power supply that supplies multiple units **shall** be restorable by operator intervention (e.g., fuse replacement) after the removal of the short-circuit, except if the short is applied upstream of the protective circuit for the power supply.

If the circuit is interrupted by the opening of a component other than a NRTL listed or recognized fuse, the test **shall** be repeated twice using new components as necessary.

## 9.11 Other Grounding Considerations

Requirements for ac system overvoltage protection are specified in GR-513-CORE, *LSSGR: Power, Section 13*.<sup>[53]</sup> COs and stations equipped with microwave radio equipment and antenna towers may require special grounding and bonding procedures as specified by the telecommunications service provider.

## 9.12 Compatibility of Former IBN Equipment With CBN Currents

This section contains criteria for tests to be performed on equipment that has traditionally been installed in an IBN but that is now intended for installation with multiple incidental or intentional connections to the CBN. The intent of these criteria is to ensure compatibility of the EUT with surge, noise, or transient currents that can be impressed on the equipment frame by the CBN.

These tests are required for equipment that has traditionally been installed in an IBN. In addition, suppliers can elect to apply these tests to high-speed equipment such as DSLAMs, COTs, and optical multiplexers installed as part of the CBN.

### 9.12.1 Test Conditions for EUT

The EUT should be fully operational, suitably configured, and should be typically loaded production equipment, including hardware, software, and firmware, for its intended application.

#### 9.12.1.1 Conditioning of the EUT

The EUT should be operated for a sufficient period of time before testing to approximate normal operating conditions.

#### 9.12.1.2 Interfacing Units and Simulators

In case the EUT is required to interact functionally with other units, the actual interfacing units should be used. Alternatively, simulators may be used to provide representative operating conditions, provided the effects of the simulator can be

isolated or identified. It is important that any simulator used in lieu of an actual interfacing unit properly represent the electrical, and in some cases the mechanical, characteristics of the interfacing unit. For example, a switching system should be loaded as follows for testing.

If the EUT principally performs call processing, traffic should be simulated by the use of “load boxes” with a sufficient number of originating and terminating lines and trunks to generate a nominal traffic load equivalent to 50% of the rated call processing capacity of the EUT. A load box is a device that generates actual physical calls on the line and trunk ports of the EUT, exercising all the resources of the EUT that would be used for live traffic. An appropriate call mix (such as dial pulse and dual-tone multifrequency) as given in GR-517-CORE<sup>[9]</sup> is to be carried by the EUT.

- When the EUT is a distributed processing system composed of both central and peripheral processing subsystems, the test load level applies only to the portion of the EUT affected by the particular test. Portions of the EUT that the tester judges to be unaffected by a particular test may be operated at lower load levels for that test. However, all units should be loaded to some extent.

For high-capacity processing systems, it may be impractical to bring the load on the EUT up to the prescribed level solely with the use of load boxes. In such cases, it is acceptable to provide additional traffic using internal traffic simulation software or other artificial means to increase the call processing load to the prescribed level. However, a minimum of 6000 calls per hour should be provided by the use of load boxes. The capability to detect and report call processing errors in the artificial traffic must be comparable to that for traffic generated by the use of load boxes.

- Other switching system functions such as data transfer, maintenance routines, and AMA should also be on-going during the testing.

As another example, a disk drive or solid state memory unit shall read, write, and transfer data, and perform any other design-intended functions during the tests.

### 9.12.1.3 DC Power Leads

The supply and return leads of the dc power cables shall be the smallest gauge consistent with the voltage-drop requirements for an operational EUT. Where a reference ground plane is used, the positive terminal of the dc supply shall be bonded to the reference ground plane.

### 9.12.1.4 Bonding Conductors

All intra-system bonding conductors shall be installed for a multi-frame EUT. In addition, any metallic conductors that provide incidental bonding paths and are normally part of the EUT installation, such as cable trays joining adjacent frames, should be installed.



### 9.12.1.5 Shelf-Mounted EUT

A small shelf-mounted EUT usually does not have direct bonding connections to the CBN, but is mounted in a frame that provides such connections. For the tests of this section, a shelf-mounted EUT is to be installed in an open unequal-flange 7-foot framework with minimal enclosure in accordance with the manufacturer's instructions.

### 9.12.1.6 Reference Plane

The reference plane, where needed (Figure 9-7, Figure 9-3, and Figure 9-5), is to be a metallic sheet (copper or aluminum) of 0.255 mm minimum thickness; other metallic materials may be used but they are to have a 0.65 mm minimum thickness. The reference plane is to project beyond the EUT by at least 0.1 m on all sides; however, the minimum size of the reference plane is to be 1 m × 1 m.

### 9.12.1.7 Test Environment

**CR9-30 [117]** The environment at the test site **shall** satisfy the following conditions.

#### 1. Ambient Radio-Noise and Signals

Because large levels of ambient radio noise can cause EUT upset similar to that caused by the application of the tests in this section, it is desirable that the conducted and radiated ambient radio-noise and signal levels, measured at the test site with the EUT de-energized, be at least 6 dB below the allowable limit of the applicable limit or standard. However, the ambient radio noise level is not relevant if the EUT complies with the criteria of this section in the presence of this noise.

#### 2. Temperature

The EUT and the measuring equipment should be within their normal operating temperature ranges.

## 9.12.2 Identification of Test Points

**R9-31 [118]** Test points **shall** be identified for application of test surges and connections to the reference ground plane. The set of test points **shall** include representative points where a connection between the EUT and CBN conductors is intended by the manufacturer. These include the point of connection to the following:

- ACEG conductor (if EUT is ac powered)
- Bonding conductors
- Communication conductors (e.g., cable shields, waveguides).



Where there are multiple identical connections to the CBN, such as several adjacent cable shields, only a single representative connection **shall** be chosen as a test point. The set of test points **shall** also include a sample of points where incidental connections to the CBN might occur, such as points of attachment to cable trays or other equipment frames.

The connection to these test points should be accomplished by connecting the test generator or the reference plane to the CBN conductor intended for that connection. In some cases, a clamp will be needed to connect to cable shields or waveguides.

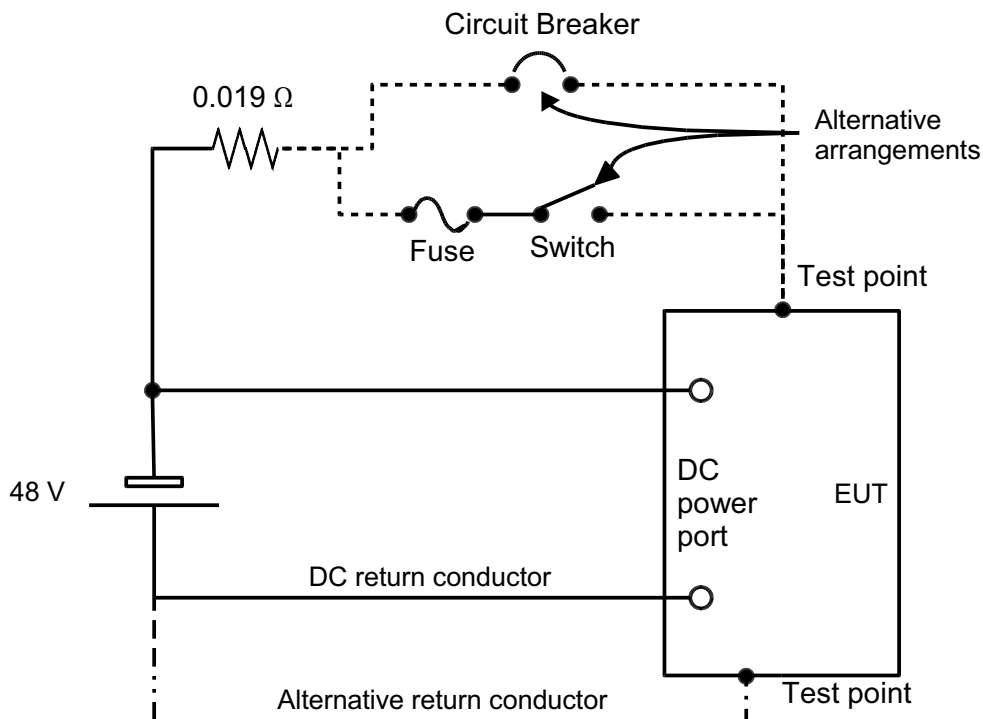
### 9.12.3 DC Fault Test

Communication equipment with multiple connections to the CBN, even if it is not dc-powered, may be subject to dc fault currents from the CBN.

**CR9-32 [119]** The EUT **shall not** be damaged and **shall** continue to operate properly during testing in accordance with the following description and the circuit shown in [Figure 9-2](#). The equipment case and the bonding connectors **shall not** suffer damage or exhibit arcing or overheating during the test. Service-affecting responses, unless within system operating limits, and manual interactions **shall not** occur. [Section 2.1.3](#) provides a description of service-affecting responses and manual intervention.

A 48-V dc source with short-circuit capacity of at least 2500A is to be connected as shown in [Figure 9-2](#). The source is to be connected to the dc port of the equipment to provide operational power. The negative terminal of the dc source is also connected to one of the test points through a resistor, a fuse and a remotely-operated switch (relay). A type-K time-delay fuse is to be used. It is acceptable to replace the switch and fuse with a circuit breaker provided that the circuit breaker time-current characteristics are equal to or greater than the time-current characteristics for the required type K time-delay fuse. These characteristics are determined by the fuse and circuit-breaker manufacturer's published data. The resistor is to be chosen so that the total impedance of the source is about 0.019Ω. The needed resistance may be obtained by coiling a length of wire or using a resistive ribbon. The fuse current rating is based on the current or fuse requirements for powering the EUT as provided in [Table 9-1](#). For each test point, the switch is to be closed discharging about 2500A through the test point until the fuse operates. If the BR terminal in the equipment is isolated from the frame, an alternative 1/0 or larger return conductor should be connected to one of the test points (typically, this would be a point of connection for a bonding conductor).

**Figure 9-2** Configuration of the DC Fault Test



**Table 9-1** Test Overcurrent Device Selection

EUT DC Current Requirements	Test Overcurrent Device Current Rating
Less than 100A (Including EUT that is not dc-powered)	100A
Between 100A and 400A	400A
Greater than 400A	Same as the fuse used for EUT powering

#### 9.12.4 Frame EFT Test

**CR9-33 [121]** The EUT **shall** perform properly when an Electrical Fast Transient (EFT) at 4 kV is applied to each test point of the EUT. Service-affecting responses, unless within system operating limits, and manual interventions **shall not** occur. Section 2.1.3 provides a description of service-affecting responses and manual intervention.

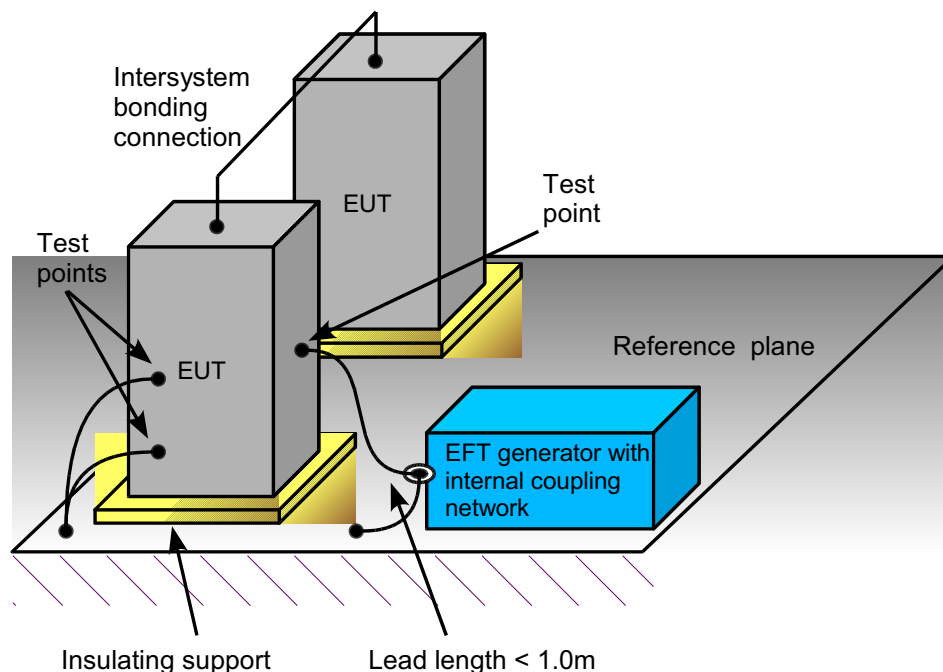
The test generator is to conform to the specifications in the international standard IEC 61000-4-4.<sup>[10]</sup> The test may be performed in a laboratory or in situ; however, the laboratory setup is preferred.

#### 9.12.4.1 Laboratory Arrangement of the EUT

The EUT should be configured as shown in Figure 9-3. All bonding conductors and shields of coaxial, paired-conductor, and ac cables that are intended for connection to the CBN and that are not connected to other equipment or the test generator should be connected to the reference plane. The EFT should be applied to each test point with all other test points connected to the reference plane. There are several options for impressing the EFT surge on the test points.

- A preferred approach is to use a commercially available coupling/decoupling network designed to apply EFT surge to the ACEG (green wire) terminal of ac power ports. To apply the surge, connect a wire between the ACEG output terminal of the EFT generator and an EUT test point.
- The output of the EFT generator can be connected to the test point through a 33-nF capacitor. IEC 61000-4-4<sup>[10]</sup> contains the performance specifications for the coupling capacitor.
- A capacitive coupling clamp can be built in compliance with IEC 61000-4-4 to impress the surge onto the bonding conductors or shielded signal conductors.

**Figure 9-3** Configuration of the Proposed EFT Frame Test



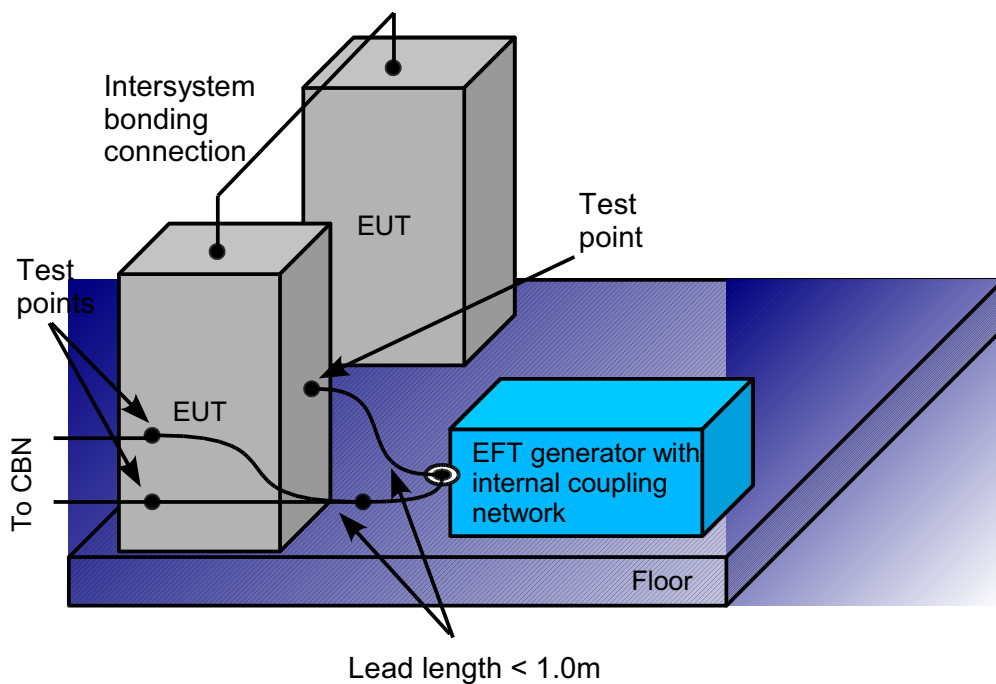
In all cases, the length of the wire between the EFT generator and the EUT should be less than 1 meter.

If BER measuring equipment or other equipment is used to verify EUT performance, an EFT discharge should be made to the ground plane to verify that this measuring or auxiliary equipment is not affected by the discharge.

#### 9.12.4.2 In-Situ Arrangement of the EUT

It may not be possible in all cases to locate the EUT in the laboratory above a reference plane as shown in Figure 9-3. In these cases the test configuration may be modified as shown in Figure 9-4. The length of the wire between the EFT generator and the EUT should be less than 1 meter.

**Figure 9-4** An Alternative Configuration for the EFT Test



#### 9.12.5 Frame Surge Test

**CR9-34 [122]** The EUT **shall not** be damaged and **shall** continue to operate properly when subjected to a 3000A, 8/20- $\mu$ s current surge applied to one of the test points of the EUT. The double exponential waveshape for the surge is defined in IEEE C62.41.<sup>[30]</sup>

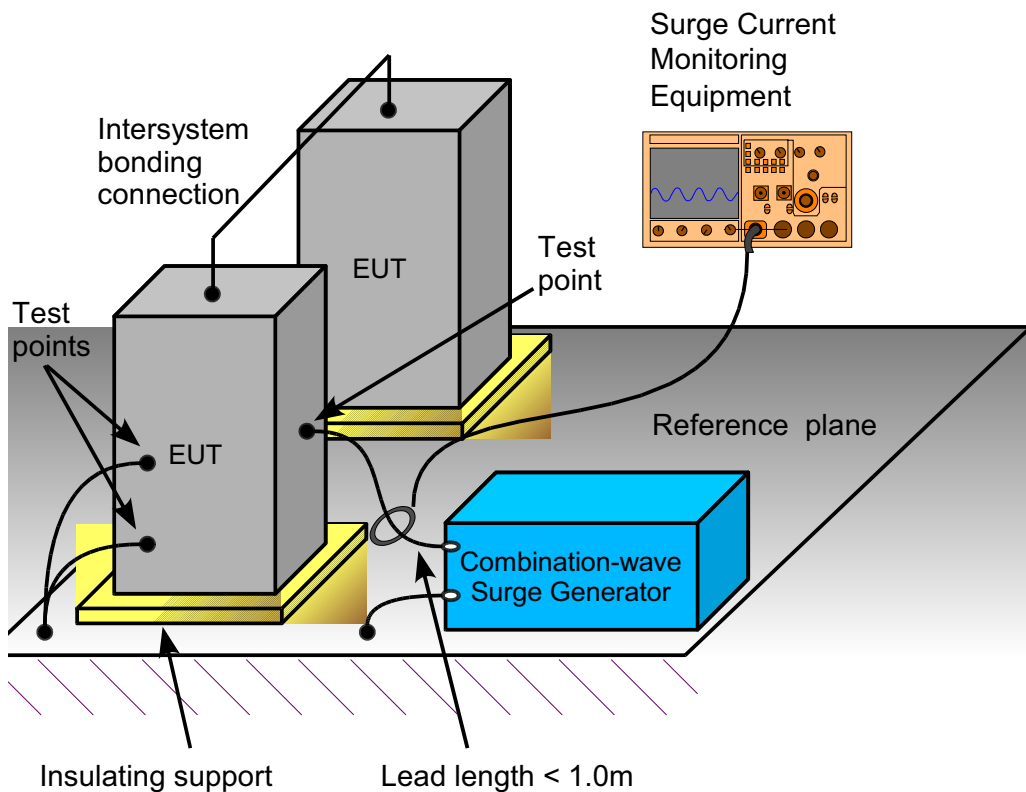
**CO9-35 [123]** The EUT **shall not** be damaged and **shall** continue to operate properly when subjected to a 5000A, 8/20- $\mu$ s current surge applied to one of the test points of the EUT. The double exponential waveshape for the surge is defined in IEEE C62.41.<sup>[30]</sup>

The test may be performed in laboratory or in situ; however, the laboratory setup is preferred.

### 9.12.5.1 Laboratory Arrangement of the EUT

The EUT is to be configured as shown in Figure 9-5. All bonding and communication conductors that are intended for the connection to the CBN and that are not connected to other equipment or the test generator should be connected to the ground plane. The surge current is to be applied to each test point with all other test points connected to the ground plane. The current in the surge generator output conductor is to be monitored. The surge generator open-circuit voltage may need to be adjusted to obtain the required peak current. The surge current rise and decay time **shall** not deviate from the calibrated values by more than 20%. If it is not possible to achieve this, the test leads may need to be shortened and the loop area of the leads decreased.

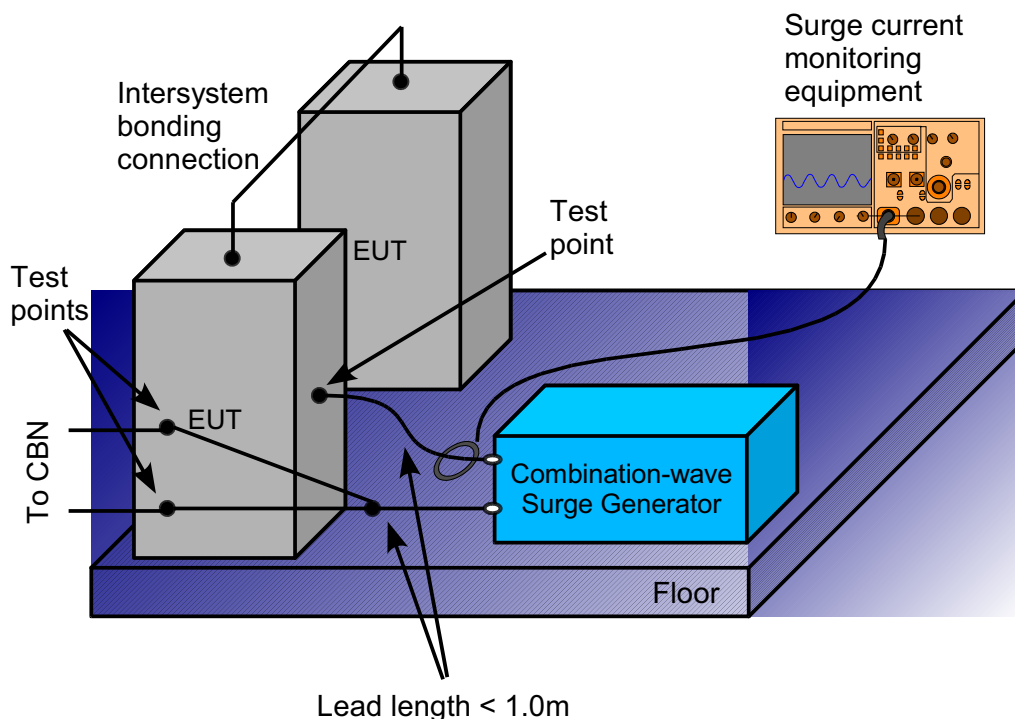
Figure 9-5 Laboratory Configuration for the Frame Surge Test



### 9.12.5.2 In-Situ Arrangement of the EUT

It may not be possible in all cases to locate the EUT in the laboratory above a reference plane as Figure 9-5 shows. In these cases, the test configuration may be modified as shown in Figure 9-6.

**Figure 9-6** In-Situ Configuration for the Frame Surge Test



### 9.12.6 AC Fault Test

The AC Fault Test applies only to equipment that contains convenience AC receptacles or other AC-powered circuits and receives the AC power from a source external to the equipment. The test does not apply to equipment where the AC receptacles or circuits are supplied from an embedded AC source.

**CR9-36 [120]** The EUT **shall** perform properly during testing in accordance with the following paragraph and test circuit shown in [Figure 9-7](#). The test **shall** be performed for a single representative AC receptacle or AC-powered circuit in each equipment cabinet. The equipment case and the bonding connectors **shall not** suffer damage or exhibit arcing or overheating during the test. Service-affecting responses, unless within system operating limits, and manual interventions **shall not** occur. [Section 2.1.3](#) provides a description of service-affecting responses and manual intervention.

Exception: AC-powered circuits where the fault test occurs and services that depend on these circuits need not be operational following the test.

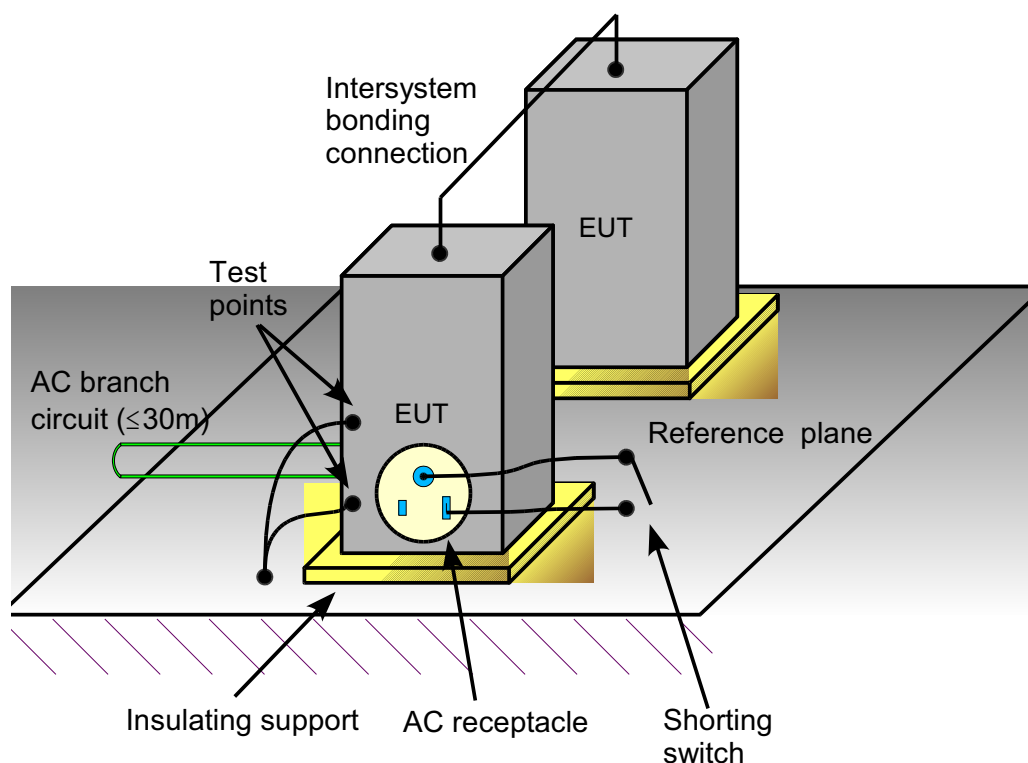
The EUT is to be configured as shown in [Figure 9-7](#) for the laboratory test or [Figure 9-8](#) for an in-situ test. For the laboratory configuration, all bonding and communication conductors that are intended for connection to the CBN and that are not connected to other equipment or the test generator should be connected to the

reference plane. An AC branch circuit with short-circuit capacity of at least 250A shall be connected to the AC circuits in the equipment and to an external AC supply source. The rating of the branch circuit and associated overcurrent protection should be selected in accordance with equipment installation instructions. For the laboratory test, the reference plane shall be bonded to the equipment grounding conductor of the supply source.

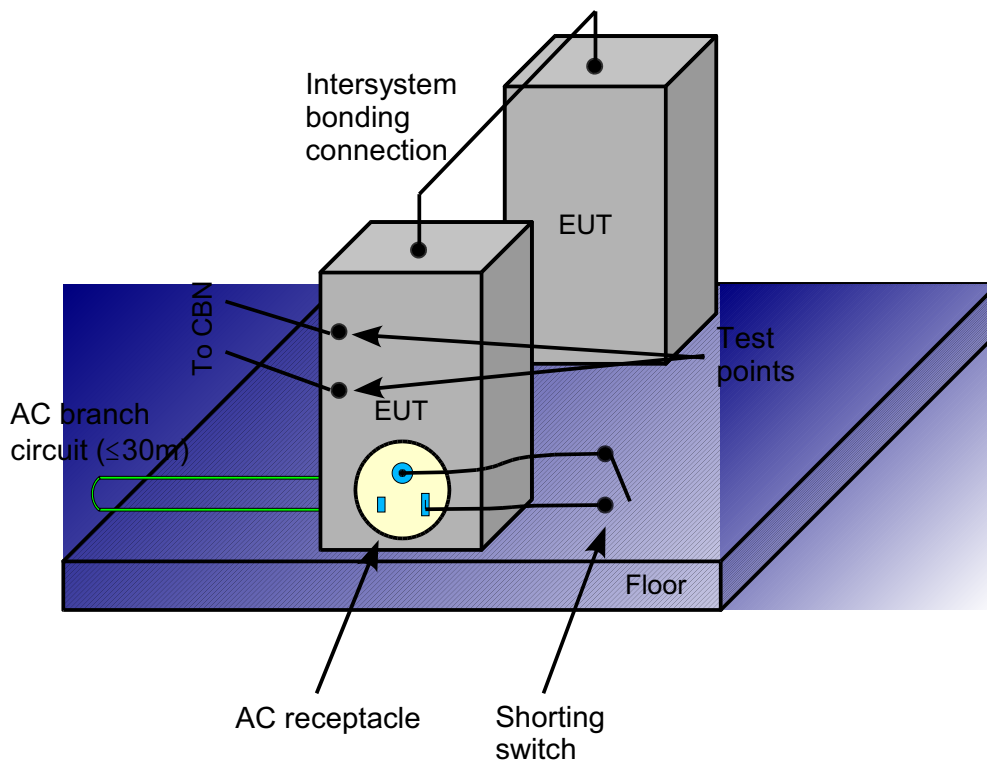
The ungrounded (i.e., phase) output of the receptacle shall be shorted to the output for the equipment grounding conductor. For AC circuits without an accessible receptacle, the short shall be initiated at any convenient location in the circuit.

For each test point, the short shall be maintained until the branch-circuit overcurrent protection device operates.

**Figure 9-7** Laboratory Configuration of the EUT for the AC Fault Test



**Figure 9-8** In-Situ Configuration of the EUT for the AC Fault Test



### 9.13 Grounding Connector for Equipment With Integrated Primary Protection

This section applies to EUT with Integrated Primary Protection (EIPP) including Equipment With Embedded Primary Protection (EEPP) (see [Appendix D](#) for definitions). [Section 4.9](#) provides detail characteristics of EIPP.

**R9-37 [214]** The primary protector and the unprotected circuit shall have a common bonding point or bar within the equipment enclosure. This common point shall be connected to the grounding means of the equipment. The grounding means of the equipment shall be sized for connection of No. 6 AWG copper grounding conductor.

**R9-38 [215]** When terminated with a No. 6 AWG or larger solid or stranded copper wire, the ground connection means of the EUT shall be capable of carrying a 60-Hz sinusoidal current of 1500 A rms for 6 seconds without evidence of cracking, breaking or melting.

To perform the test, the grounding connection means is to be connected to a No. 6 AWG solid or stranded copper conductor (not less than 2 ft.) terminated in the connector secured by a torque of 15 in.-lbs. The return lead of the generator is to be connected to the common bonding point inside the EUT. The test current of



1500 A rms for 6 seconds shall be passed in series from the free end of the conductor through the connector. The grounding connector shall display no evidence of cracking, breaking, or melting.

### 9.13.1 Grounding Conductors in the EIPP

**R9-39 [216]** Unless fusing takes place on the EUT board, a discrete protector block shall be connected to the grounding means of the EUT using a grounding conductor not smaller than specified in [Table 9-2](#).

**Table 9-2** Grounding Conductor Size for Fuse-Less Protector Block in the EUT

Number of Protected Circuits	Minimum Size of Grounding Conductor
5	12 AWG
6	10 AWG
7 or more	6 AWG

**R9-40 [217]** If fusing takes place on the EUT board, the board containing the protectors shall be connected to the grounding means of the EUT using a grounding conductor not smaller than specified [Table 9-3](#).

**Table 9-3** Grounding Conductor Size for Fused Protector Block in the EUT

Number of Protected Circuits	Minimum Size of Grounding Conductor
6	12 AWG
7	10 AWG
8 or more	6 AWG



# 10 Criteria for DC Power Port of Telecommunications Load Equipment

The criteria in this section apply to the telecommunications equipment that is powered from a shared dc power plant. The criteria are adopted from ANSI T1.315-2001,<sup>[54]</sup> *Voltage Levels for DC-Powered Equipment Used in Telecommunications Environment*.

Annex C of T1.315-2001 provides guidance on testing methods and suggested test circuits. The suggested test circuits in ANSI T1.315-2001 may require modification to achieve the test waveforms and/or proper operation of the telecommunications equipment. Other suitable test methods may be used in place of the test methods suggested by the ANSI T1.315-2001. This section specifies tolerances on the transient waveforms since tolerances for the transient waveforms are not included in ANSI T1.315-2001. The applied transients shall be characterized at the point where the generator, including its connecting or test leads, connects to the EUT terminals.

The EUT performance criteria are evaluated in accordance with the applicable Telcordia Generic Requirements, national standards and international standards, or in an agreement between the manufacturer and the user.

The objectives will become requirements 1 year from the publication date of this version of GR-1089-CORE. With the understanding that this objective is new to equipment manufacturers, this 1-year grace period should provide ample time to make equipment modifications, if necessary, to meet the requirement in the future.

## 10.1 Input DC Voltage

The criteria in this section are based on Section 5.1 of ANSI T1.315-2001.<sup>[54]</sup>

- O10-1 [218]** The equipment **shall** operate within the input minimum and maximum voltage values of the correct polarity specified in Tables 1 and 2 of ANSI T1.315-2001 for each nominal voltage power plant.

## 10.2 Minimum Operating Voltage

The criteria in this section are based on Section 5.2 of ANSI T1.315-2001.<sup>[54]</sup>

- O10-2 [219]** The manufacturer should determine the appropriate minimum steady-state voltage from Table 1 or 2 in ANSI T1.315<sup>[54]</sup> at which the equipment remains fully operational and should verify the equipment will recover to a fully operational state after losing power. The manufacturer should specify in the documentation the minimum steady-state voltage and nominal voltage of the system stated in Table 1 or 2 in ANSI T1.315.<sup>[54]</sup>

**Test Procedure:**

- A. With fully loaded equipment (e.g., with maximum configurations of cards and shelves), apply the minimum steady-state voltage, based on the nominal voltage of the system stated in Table 1 or 2 in ANSI T1.315,<sup>[54]</sup> to the input terminals and verify normal operation of the equipment. Lower the input voltage by 1 V and hold for 30 seconds. Record the voltage, current drain and whether or not the equipment is operating normally.
- B. Continue to lower the input voltage in 1-volt increments as above until abnormal operation of the equipment is observed. Record the minimum voltage and associated current at which the equipment remains fully operational. Record the voltage and current.
- C. Continue to lower the input voltage in 5-volt increments for 30 seconds at a time until reaching 0 V. There must be no damage to equipment
- D. Return the input voltage within the limits specified in Section 10.1. The equipment must restart without manual intervention and return to normal operation within 30 minutes.

### 10.3 Undervoltage Transient

This transient is only applicable to the 48 V dc power input to the telecommunications load equipment. The criteria in this section are based on the undervoltage transient criteria specified in Section 5.4 of ANSI T1.315-2001.<sup>[54]</sup> Annex C.2.3 and Figure C.4 in ANSI T1.315-2001 provide a test procedure and a suggested test circuit to verify these criteria. The specification of the test generator is defined in Annex C.1 of ANSI T1.315-2001. The undervoltage transient waveform in Figure 4 of ANSI T1.315-2001 should be measured at an appropriate load relative to the EUT in accordance with IEC 61000-4-11, *Testing and measurement techniques – Voltage dips, short interruptions and voltage variations immunity tests*.<sup>[55]</sup> The tolerances of the undervoltage transient waveform are given in Table 10-1.

- 
- O10-3 [220]** The equipment should not be damaged when the undervoltage transient defined in Figure 4 of ANSI T1.315-2001<sup>[54]</sup> is applied at the dc power input terminals and the redundant power feeds are disabled. After the application of the undervoltage transient, the equipment **shall** automatically return to its normal operation without manual intervention upon restoration of normal voltage conditions.
- O10-4 [221]** The equipment should not be damaged and should continue to operate during and following the undervoltage transient defined in Figure 4 of ANSI T1.315-2001<sup>[54]</sup> when the undervoltage transient is applied at the dc power input terminals.
-

**Table 10-1** Undervoltage Transient Waveform Characteristics (Figure 4 of ANSI T1.315-2001)

Waveform Characteristics	Nominal	Tolerance Range
Undervoltage Transient Level	-5 V	-4 to -5 V
Falltime	10 $\mu$ s	0 to 12 $\mu$ s
Duration at the Undervoltage Transient Level	10 ms	10 to 12 ms
Risetime	< 5 $\mu$ s	0 to 5 $\mu$ s

## 10.4 Overvoltage Transient

This transient is only applicable to the 48 V dc power input to the telecommunications load equipment. The criteria in this section are based on the overvoltage transient criteria specified in Sections 5.3 and 5.4 of ANSI T1.315-2001.<sup>[54]</sup> Annex C.2.2 and Figure C.3 in ANSI T1.315-2001 provide a test procedure and a suggested test circuit to verify these criteria. The specification of the test generator is defined in Annex C.1 of ANSI T1.315-2001. The overvoltage transient waveform in Figure 3 of ANSI T1.315-2001 should be measured at an appropriate load relative to the EUT in accordance with IEC 61000-4-11.<sup>[55]</sup> The tolerances of the overvoltage transient waveform are given in Table 10-2.

- O10-5 [222]** The equipment should not be damaged and should continue to operate during and following the overvoltage transient defined in Figure 3 of ANSI T1.315-2001<sup>[54]</sup> when the overvoltage transient is applied at the dc power input terminals.

**Table 10-2** Overvoltage Transient Waveform Characteristics (Figure 3 of ANSI T1.315-2001)

Waveform Characteristics	Nominal	Tolerance Range
Overvoltage Transient Level	-75 V	-75 to -95 V
Risetime	< 2 $\mu$ s	0 to 2 $\mu$ s
Duration at the Overvoltage Transient Level	10 ms	10 to 12 ms
Slope	10 V/ms	9 to 11 V/ms

## 10.5 Impulse Transient

This transient is only applicable to the 48 V dc power input to the telecommunications load equipment. The criteria in this section are based on the impulse transient criteria specified in Section 5.4 of ANSI T1.315-2001.<sup>[54]</sup> Annex C.2.1 and Figure C.2 in ANSI T1.315-2001 provide a test procedure and a suggested test circuit to verify these criteria. The impulse transient waveform in Figure 2 of ANSI T1.315-2001 should be measured without the presence of the EUT and power supply in accordance with Appendix C. The combination wave generator defined in IEEE C62.41.2<sup>[30]</sup> is typically used as the transient source (see Figure C.2 of ANSI T1.315-2001). The tolerances of the impulse transient waveform are given in Table 10-3.

**NOTE:** Annex C.2.1 in ANSI T1.315-2001 states that a 2kV surge into the circuit in Figure C.2 will result in a 50 V transient across the 0.5 ohm resistor. However, to achieve a 50 V transient across the 0.5 ohm resistor the surge generator needs to be set to 2.25 kV.

- O10-6 [223]** The equipment should not be damaged and should continue to operate during and following the impulse transient defined in Figure 2 of ANSI T1.315-2001<sup>[54]</sup> when the impulse transient is applied at the dc power input terminals.

**Table 10-3** Impulse Transient Waveform Characteristics (Figure 2 of ANSI T1.315-2001)

Waveform Characteristics	Nominal	Tolerance Range
Overvoltage Transient Level	-100 V	-100 to -120 V
Risetime	< 2 $\mu$ s	0 to 2 $\mu$ s
Falltime to Half	50 $\mu$ s	28 to 60 $\mu$ s

## 10.6 Single Transient

This test shall not be performed if the tests described in Sections 10.3, 10.4, and 10.5 are performed. This transient is only applicable to the 48 V dc power input to the telecommunications load equipment. The criteria in this section are based on the impulse transient criteria specified in Section 5.4 of ANSI T1.315-2001.<sup>[54]</sup> Annex C.1 and Figure C.1 in ANSI T1.315-2001 provide a test procedure and a suggested test circuit to verify these criteria. The single impulse waveform shall be characterized as described in Sections 10.3, 10.4, and 10.5. The tolerances of the single transient waveform are given in Table 10-1, Table 10-2, and Table 10-3.

- CO10-7 [224]** The criteria described in Sections 10.3, 10.4, and 10.5 should be considered met if the single transient defined in Figure 1 of ANSI T1.315-2001<sup>[54]</sup> is applied at the dc power input terminals.

## 10.7 Noise Returned by the Network Equipment (Noise Emission)

The criteria in this section are based on the noise returned by telecommunications load equipment criteria specified in Section 5.5.2 of ANSI T1.315-2001.<sup>[54]</sup> The conducted emissions criteria in Section 3 of GR-1089-CORE provide criteria for common-mode emissions (all conductors to ground). The criteria in this section provide criteria for noise in differential mode (e.g., -48V to the BR or 24V to the BR).

Figure 6 of Section 5.5.2 in ANSI T1.315-2001<sup>[54]</sup> illustrates a suggested test circuit for performing tests to verify these criteria.

### 10.7.1 Voice Frequency Noise Emission

- O10-8 [225]** The conducted voice frequency noise measured at the dc power port of the network equipment should not exceed the following limit:

$$9 + 10\log I_c \quad \text{dBmC}$$

where  $I_c$  is the maximum measured input current of telecommunications load equipment (or grouping of telecommunications load equipment) or 1 A, whichever is greater. Noise emission measurements for voice frequency should be performed with a noise measuring set with C-message weighting as specified in IEEE Std. 743-1995.<sup>[56]</sup>

### 10.7.2 Wideband Frequency Noise Emission

- O10-9 [226]** The wideband frequency noise at the dc power port of network equipment should not exceed the following limit:

$$\sqrt{I_c} \quad \text{mV}_{\text{rms}} \text{ (in any 3-kHz band from 10 kHz to 20 MHz)}$$

where  $I_c$  is the rated input current or 1 A, whichever is greater.

### 10.7.3 Broadband Noise Emission

- O10-10 [227]** The broadband noise at the dc power port of network equipment should not exceed 250 mV peak-to-peak. The measurement should be performed with an oscilloscope with at least 400 MHz bandwidth and scope probes of 100 MHz bandwidth.

## 10.8 Power Input Noise Immunity

The criteria in this section are based on the noise immunity criteria specified in Section 5.5.1 of ANSI T1.315-2001.<sup>[54]</sup> The conducted immunity criteria in Section 3 of GR-1089-CORE provide criteria for common-mode immunity (all conductors to ground). The criteria in this section provide criteria for noise in differential mode (e.g., -48V to the BR or 24V to the BR).

Figure 5 of Section 5.5.1 in ANSI T1.315-2001<sup>[54]</sup> illustrates a suggested test circuit for performing tests to verify these requirements.

### 10.8.1 Voice Frequency Noise Immunity

---

**O10-11 [228]** The network equipment should operate and should meet its applicable requirements when its dc power port is subjected to conducted voice frequency noise equal to C Message 56 dBmC at 600 ohms.

---

### 10.8.2 Wideband Frequency Noise Immunity

---

**O10-12 [229]** The network equipment should operate and should meet its applicable requirements when its dc power port is subjected to conducted wideband frequency noise equal to 100 mV rms in any 3-kHz band between 10 kHz and 20 MHz.

---

### 10.8.3 Broadband Noise Immunity

---

**O10-13 [230]** The network equipment should operate and should meet its applicable requirements when its dc power port is subjected to wideband noise equal to

- 240 mV peak-to-peak for 24 nominal voltage.
- 480 mV peak-to-peak for 48 nominal voltage.

---

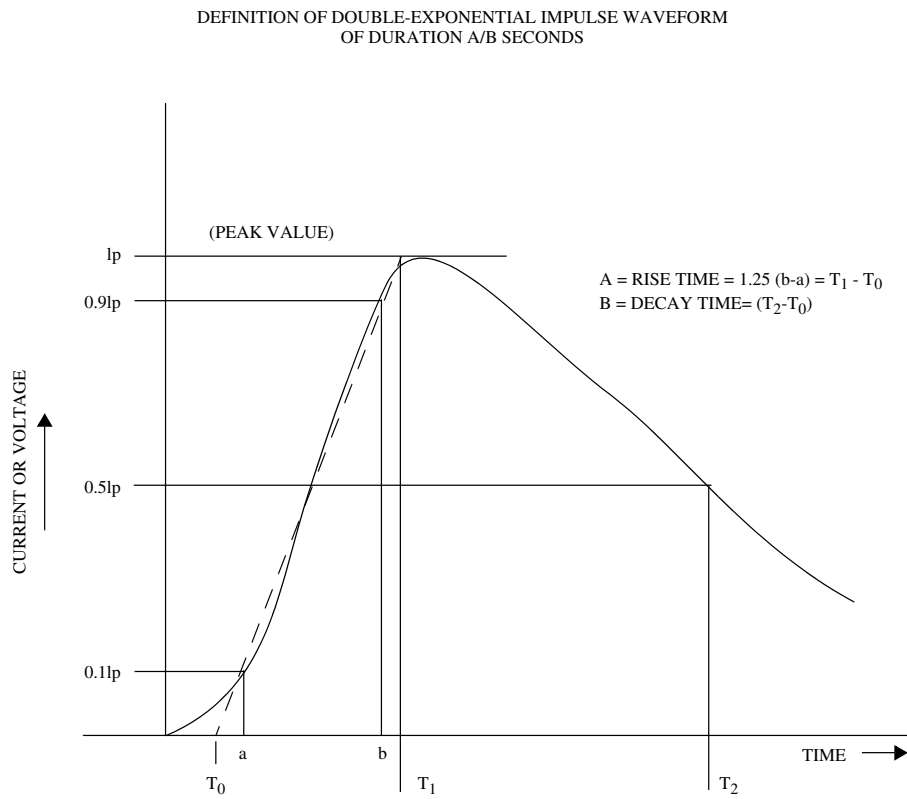


## Appendix A: Definition of Double-Exponential Impulse Waveform

Figure A-1 is the voltage/current waveshape that is used to perform lightning surge immunity tests. The rise time (A) is the maximum rise time permitted; that is, rise times of shorter duration may be used. The decay time (B) is the minimum decay time permitted; that is, decay times of longer duration may be used.

Table A-1 lists the permissible waveform tolerance.

Figure A-1 Impulse Waveform



**Table A-1** Waveform Tolerances

<b>A/B Waveform (<math>\mu\text{s}</math>)</b>	<b>Condition</b>	<b>Edge</b>	<b>Tolerance Time</b>	<b>Amplitude</b>
2/10	Open-Circuit Voltage	Rise (A)	0 $\mu\text{s}$ to -1.0 $\mu\text{s}$	0% to +20%
		Duration (B)	0 $\mu\text{s}$ to +7 $\mu\text{s}$	
	Short-Circuit Current	Rise (A)	0 $\mu\text{s}$ to -1.0 $\mu\text{s}$	0% to +20%
		Duration (B)	0 $\mu\text{s}$ to +7 $\mu\text{s}$	
10/250	Open-Circuit Voltage	Rise (A)	0 $\mu\text{s}$ to -6.0 $\mu\text{s}$	0% to +16%
		Duration (B)	0 $\mu\text{s}$ to +150 $\mu\text{s}$	
	Short-Circuit Current	Rise (A)	0 $\mu\text{s}$ to -3.0 $\mu\text{s}$	0% to +16%
		Duration (B)	0 $\mu\text{s}$ to +50 $\mu\text{s}$	
10/360	Open-Circuit Voltage	Rise (A)	0 $\mu\text{s}$ to -2.5 $\mu\text{s}$	0% to +15%
		Duration (B)	0 $\mu\text{s}$ to +108 $\mu\text{s}$	
	Short-Circuit Current	Rise (A)	0 $\mu\text{s}$ to -2.5 $\mu\text{s}$	0% to +15%
		Duration (B)	0 $\mu\text{s}$ to +108 $\mu\text{s}$	
10/1000	Open-Circuit Voltage	Rise (A)	0 $\mu\text{s}$ to -4.0 $\mu\text{s}$	0% to +15%
		Duration (B)	0 $\mu\text{s}$ to +500 $\mu\text{s}$	
	Short-Circuit Current	Rise (A)	0 $\mu\text{s}$ to -4.0 $\mu\text{s}$	0% to +15%
		Duration (B)	0 $\mu\text{s}$ to +500 $\mu\text{s}$	

## Appendix B: Application Guidelines

**Appendix B** provides guidance in the application of the criteria contained in GR-1089-CORE. The criteria are divided into two sets, Criteria Sets A and B:

- Criteria Set A applies to all network equipment regardless of port types that may be used in telecommunications facilities as described in **Appendix B.1**. These criteria are ESD in Section 1, Section 2, radiated emission and immunity criteria in Section 3, electrical safety criteria in Section 7, and bonding and grounding in Section 9. **Table B-1** indicates the criteria of **Set A** that are applicable to all network equipment regardless of port types.

**Table B-1** Applicable Criteria Set A for Network Equipment

Section Number in GR-1089	Description
1	Introduction
2.1	System-Level Electrostatic Discharge (ESD)
3.2.1	Radiated Emissions Criteria
3.3.1	Radiated Immunity Criteria
7	Electrical Safety Criteria
9	Bonding and Grounding

- Criteria Set B applies to specific interface ports (e.g., telecommunications ports), its connection to the telecommunications network (e.g., OSP, intrabuilding), and the intended physical location of the network telecommunications equipment (e.g., COs, customer premises). These criteria are EFT in Section 2, conducted emission and immunity criteria in Section 3, lightning and power fault in Section 4, steady-state power induction in Section 5, DC potential difference in Section 6, corrosion in Section 8, and transients on dc power port in Section 10. **Table B-2** indicates the criteria of Set B that are applicable to specific interface ports of network equipment. **Appendix B.1** presents the application guidelines for equipment ports.

**Table B-2** Applicable Criteria Set B for Network Equipment Ports (Sheet 1 of 2)

Section Number in GR-1089	Description
2.2	Electrical Fast Transient (EFT)
3.2.2	Conducted Emission Criteria for Power Ports
3.2.3	Conducted Emission Criteria for Telecommunications Ports
3.3.2	Conducted Immunity Criteria for AC and DC Power Ports
3.3.3	Conducted Immunity Criteria for Telecommunications Ports

**Table B-2** Applicable Criteria Set B for Network Equipment Ports (Sheet 2 of 2)

Section Number in GR-1089	Description
4.6	Criteria for Equipment Interfacing With Telecommunications Ports
4.7	Lightning Protection Tests for Equipment To Be Located in High-Exposure Customer Premises and OSP Facilities (Type 3 and 5 Telecommunications Ports)
4.8	Criteria for Equipment Interfacing With Agreed Primary Protection
4.9	Criteria for Equipment With Integrated Primary Protection
4.10	Criteria for Equipment Interfacing With Coaxial Cable Ports
4.11	Lightning Criteria for Equipment Interfacing With Antennas
4.12	Lightning Criteria for Equipment Interfacing With AC Power Port(s)
4.13	Lightning Criteria for Equipment Interfacing With DC Power Port(s)
5	Steady-State Power Induction
6	DC Potential Difference
8	Corrosion
10	Criteria for DC Power Port of Telecommunications Load Equipment

## B.1 Application Guidelines for Equipment Ports

Table B-3, Application Chart for Equipment Ports, is presented as a guide for applying the applicable criteria for Set B. Application of the various criteria is a function of the type of equipment port under consideration, its connection to the telecommunications network, and the intended physical location of the equipment port. Ports described in this GR are telecommunications ports, power ports (ac and dc), coaxial ports, and antenna ports. The definitions of the ports are contained in Appendix D. An EUT may have more than one type port. Each type port of EUT must be tested to the applicable tests.

For the purpose of determining the applicable criteria, network equipment ports have been grouped into several types. It will be necessary to determine which of the various types best apply to the port under test. Once the equipment port has been categorized, Table B-3 may be used to determine the applicable criteria. The equipment manufacturer has the responsibility for classifying all equipment ports associated with the EUT and the test laboratory shall clearly identify the classification of all ports in the test report for equipment that has been evaluated in accordance with this Appendix. The manufacturer shall consult relevant Telcordia

GRs, if available, for determining the appropriate port(s) classification. It is also recommended that manufacturers consult with the LEC for determining the appropriate port(s) classification. The types of equipment ports are defined below:

- Type 1 Equipment port(s) directly connected to metallic outside-plant cable conductors (e.g., tip and ring conductors, coaxial cable) or through a series non-isolating device (e.g., splitter), and intended to be placed in network facilities such as COs, Electronic Equipment Enclosures (EEEs), Controlled Environmental Vaults (CEVs), and huts. Examples of this type port include equipment ports that provide services such as voice (e.g., switches), data (e.g., DSL technologies), multiplexing (e.g, digital carrier), and broadband coaxial communications.
- Type 2 Equipment port(s) not directly connected to metallic outside-plant cable conductors (e.g., tip and ring conductors, coaxial cable) including equipment isolated from the outside plant electrically or optically, and intended to be placed in network facilities such as COs, EEEs, Electronic Equipment Cabinets (EECs), CEVs, or huts. Examples of this type port include equipment ports that provide services such as Digital Signal Cross-Connect (DSX), 10BaseT, 100BaseT, GigE, and Signaling Transfer Point (STP).
- Type 3 Equipment port(s) directly connected to metallic outside-plant cable conductors (e.g., tip and ring conductors, coaxial cable) or through a series non-isolating device (e.g., splitter), and intended to be located on customer premises. This includes ports that are connected to lines that are intended to leave the premises. Examples of this type port include equipment ports that provide services such as voice (e.g., switches), data (e.g., DSL services), multiplexing (e.g, digital carrier system Remote Terminals), and broadband coaxial communications.
- Type 4 Equipment port(s) not directly connected to metallic outside-plant cable conductors (e.g., tip and ring conductors, coaxial cable) including equipment isolated from the outside plant electrically or optically, and intended to be located on customer premises. Examples of this type port include customer side ports of equipment that provide services such as voice (e.g., NIUs), data (e.g., NIUs, ONTs), multiplexing (e.g., digital carrier system Remote Terminals), and broadband coaxial communications.
- Type 5 Equipment port(s) directly connected to metallic cable conductors (e.g., tip and ring conductors, coaxial cable) or through a series non-isolating device (e.g., splitter), and intended to be deployed in outside plant facilities such as EECs, pedestal terminal closures, and ONU closures. Examples of this type port include equipment ports that provide services such as voice (e.g., DLC), data (e.g., DSL technologies), and multiplexing (e.g., digital carrier system Remote Terminals).

- Type 6      Equipment port(s) directly connected to antennas external to the structure. Examples of this type port include equipment ports that provide cellular services.
- Type 7      Equipment port(s) directly connected to ac power systems.
- Type 8      Equipment port(s) directly connected to local dc power systems.

**NOTE:** Cabling and wiring that is part of the same physical installation, even if it exits a building, cabinet, or enclosure for a short distance, should generally be classified as intra-building. Some examples of this include cross-connecting and inter-connecting cables between OSP equipment that are part of the same physical installation, customer ports of premises mounted ONTs or active NIDs that are isolated from the OSP, etc.

**NOTE:** The Type 2 and 4 ports' interface(s) MUST NOT be metallically connected to interfaces which connect to the Outside Plant or its wiring. These interfaces are designed for use as intra-building interfaces only. The addition of primary protectors is not sufficient protection in order to connect these interfaces metallically to OSP wiring.

**Table B-3** Application Chart for Equipment Ports (Sheet 1 of 3)

Section	Description	Equipment Port Type							
		1	2	3	4	5	6	7	8
2.2	Electrical Fast Transient (EFT)	X	X	X	X			X	X
3.2.2	Conducted Emission Criteria for Power Ports							X	X
3.2.3	Conducted Emission Criteria for Telecommunications Ports	X	X	X	X	X			
3.3.2	Conducted Immunity Criteria for AC and DC Power Ports							X	X
3.3.3	Conducted Immunity Criteria for Telecommunications Ports	X	X	X	X	X			
4.6	Criteria for Equipment Interfacing With Telecommunications Ports								
4.6.5	Short-Circuit Tests (Telecommunications Type 1, 3, and 5 Ports)	X		X		X			
4.6.6	First-Level Lightning Surge Tests (Telecommunications Type 1, 3, and 5 Ports)	X		X		X			
4.6.7	First-Level Lightning Protection Tests (Telecommunications Type 1, 3, and 5 Ports)	X		X		X			
4.6.8	Second-Level Lightning Surge Tests (Telecommunications Type 1, 3, and 5 Ports)	X		X		X			

**Table B-3** Application Chart for Equipment Ports (Sheet 2 of 3)

Section	Description	Equipment Port Type							
		1	2	3	4	5	6	7	8
4.6.9	First-Level Intra-Building Lightning Surge Tests (Telecommunications Type 2 and 4 Ports)		X		X				
4.6.10	First-Level AC Power Fault Tests (Telecommunications Type 1, 3, and 5 Ports)	X		X		X			
4.6.11	Current-Limiting Protector Tests for Equipment To Be Located at Network Facilities (Type 1 Telecommunications Port)	X							
4.6.12	Second-Level AC Power Fault Tests for Equipment To Be Located at Network Facilities (Type 1 Telecommunications Port)	X							
4.6.13	Second-Level AC Power Fault Tests for Series-Type Equipment To Be Located at Network Facilities (Type 1 Telecommunications Port)	X							
4.6.14	Fusing Coordination Tests for Equipment To Be Located on Customer Premises and OSP Facilities (Type 3 and 5 Telecommunications Ports)			X		X			
4.6.15	Second-Level AC Power Fault Tests for Equipment To Be Located on Customer Premises and OSP Facilities (Type 3 and 5 Telecommunications Ports)			X		X			
4.6.16	Second-Level AC Power Fault Tests for Series-Type Equipment To Be Located on Customer Premises and OSP Facilities (Type 3 and 5 Telecommunications Ports)			X		X			
4.6.17	Second-Level Intra-Building AC Power Fault Tests for Equipment To Be Located on Customer Premises (Type 4 Telecommunications Port)				X				

**Table B-3** Application Chart for Equipment Ports (Sheet 3 of 3)

Section	Description	Equipment Port Type							
		1	2	3	4	5	6	7	8
4.7	Lightning Protection Tests for Equipment To Be Located in High-Exposure Customer Premises and OSP Facilities (Type 3 and 5 Telecommunications Ports)			X		X			
4.8	Criteria for Equipment Interfacing With Agreed Primary Protection			X		X			
4.9	Criteria for Equipment With Integrated Primary Protection			X		X			
4.10	Criteria for Equipment Interfacing With Coaxial Cable Ports								
4.10.2	Short-Circuit Tests	X		X		X			
4.10.3.1	First-Level Lightning and Power Fault Tests	X		X		X			
4.10.3.2	Second-Level Lightning and Power Fault Tests	X		X		X			
4.10.4.1	First-Level Lightning and Power Fault Tests	X		X		X			
4.10.4.2	Second-Level Lightning and Power Fault Tests	X		X		X			
4.10.5	First-Level Intrabuilding Surge Tests		X		X				
4.10.6	Additional Criteria for Equipment Intended for the OSP	X		X		X			
4.11	Lightning Criteria for Equipment Interfacing With Antennas						X		
4.12	Lightning Criteria for Equipment Interfacing With AC Power Port(s)							X	
4.13	Lightning Criteria for Equipment Interfacing With DC Power Port(s)								X
5	Steady-State Power Induction	X		X		X			
6	DC Potential Difference	X		X		X			
8	Corrosion	X		X		X			
10	Criteria for DC Power Port of Telecommunications Load Equipment								X



## Appendix C: References

1. GR-295-CORE, *Mesh and Isolated Bonding Networks: Definition and Application to Telephone Central Offices*.
2. FR-64, *LATA Switching Systems Generic Requirements (LSSGR)*.
3. GR-209-CORE, *Generic Requirements for Product Change Notices (PCNs)*.
4. FR-440, *Transport Systems Generic Requirements (TSGR)*.
5. FR-2063, *Network Equipment-Building Systems (NEBST<sup>TM</sup>) Family of Requirements (NEBSFR)*.
6. GR-78-CORE, *Generic Requirements for the Physical Design and Manufacture of Telecommunications Products and Equipment*.
7. IEC 61000-4-2 (2001-04) Ed 1.2, *Electromagnetic compatibility (EMC) - Part 4-2: Testing and measurement techniques - Electrostatic discharge immunity test*.
8. EIA-471-1996, *Symbol and Label for Electrostatic Sensitive Devices*.
9. GR-517-CORE, *LSSGR: Traffic Capacity and Environment (a module of LSSGR, FR-64)*.
10. IEC Standard 61000-4-4 (2004-07) Ed 2.0, *Electromagnetic compatibility (EMC) - Part 4-4: Testing and measurement techniques - Electrical fast transient/burst immunity test*.
11. *Code of Federal Regulations* (Washington, DC: Federal Communications Commission), Title 47, Chapter 1, Part 15.
12. *Code of Federal Regulations* (Washington, DC: Federal Communications Commission), Title 47, Chapter 1, Part 68.
13. ANSI/TIA-EIA-968-A, October 2002, *Telecommunications - Telephone Terminal Equipment - Technical Requirements for Connection of Terminal Equipment to the Telephone Network*.
14. ANSI C63.4-2003, *American National Standard Methods for Measurement of Radio Noise Emissions from Low-Voltage Electrical and Electric Equipment in the Range of 9 kHz to 40 GHz*.
15. ANSI C63.2-1996, *American National Standard for Electromagnetic Noise and Field Strength Instrumentation, 10 kHz to 40 GHz*.
16. CISPR 16-1-1 (2003-11), First Edition, *Specification for radio disturbance and Immunity measuring apparatus and methods, Part 1-1: Radio disturbance and immunity measuring apparatus – Measuring apparatus*.
17. MIL-STD-461E, 20 August 1999, *Requirements for the control of electromagnetic interference characteristics of subsystems and equipment*.
18. CISPR 16-1-2 (2004-06), Edition 1.1, *Specification for radio disturbance and Immunity measuring apparatus and methods, Part 1-2: Radio disturbance and immunity measuring apparatus – Ancillary equipment – Conducted disturbances*.

19. ANSI C63.5-2004, *American National Standard for Electromagnetic Compatibility - Radiated Emission Measurements in Electromagnetic Interference (EMI) Control - Calibration of Antennas.*
20. ANSI C63.7-1992, *American National Standard for Construction of Open-Area Test Sites for Performing Radiated Emission Measurements.*
21. ANSI C63.6-1996, *American National Standard Guide for the Computation of Errors in Open-Area Test Site Measurements.*
22. ANSI C63.12-1999, *American National Standard Recommended Practice on Procedures for Control of System Electromagnetic Compatibility.*
23. CISPR 22 (2005-04), Fifth Edition, *Information technology equipment-Radio disturbance characteristics - Limits and methods of measurement.*
24. GR-507-CORE, *LSSGR: Transmission, Section 7 (a module of LSSGR, FR-64).*
25. GR-1244-CORE, *Clocks for the Synchronized Network: Common Generic Criteria.*
26. IEC 61000-4-3 (2002-09) Ed 2.1, *Electromagnetic compatibility (EMC) - Part 4-3: Testing and measurement techniques - Radiated, radio-frequency, electromagnetic field immunity test.*
27. M. L. Crawford and J. L. Workman, *Using a TEM Cell for EMC Measurements of Electronic Equipment*, Technical Note 1013, April 1979 (National Bureau of Standards).
28. IEC Standard 61000-4-6 (2004-11) Ed 2.1, *Electromagnetic compatibility (EMC) - Part 4: Testing and measurement techniques - Section 6: Immunity to conducted disturbances, induced by radio-frequency fields.*
29. GR-1-CORE, *Lightning, Radio Frequency, and 60-Hz Disturbances at the Regional Bell Operating Company Network Interface.*
30. ANSI/IEEE C62.41.2-2002, *IEEE Recommended Practice On Characterization of Surges in Low-Voltage (1000 V and less) in AC Power Circuits.*
31. GR-974-CORE, *Generic Requirements for Telecommunications Line Protector Units (TLPUs).*
32. UL 1459, Second Edition, *Standard for Telephone Equipment.*
33. UL 60950-1, First Edition, *Information Technology Equipment – Safety – Part 1: General Requirements*
34. GR-1361-CORE, *Generic Requirements for Gas Tube Protector Units (GTPUs).*
35. GR-2916-CORE, *Generic Requirements for a 5 Pin Protector Block Assembly.*
36. GR-49-CORE, *Generic Requirements for Outdoor Telephone Network Interface Devices (NIDs).*
37. GR-2890-CORE, *Active Network Interface Device (Residential Gateway).*
38. GR-239-CORE, *Generic Requirements for Indoor Telephone Network Interface Devices (NIDs).*

39. GR-421-CORE, *Generic Requirements for Metallic Telecommunications Cables.*
40. GR-492-CORE, *Generic Requirements for Metallic Telecommunications Wire.*
41. TR-TSY-000056, *Repeater Housings for T1, T1C, T1D, and T1G Carrier Systems.*
42. GR-487-CORE, *Generic Requirements for Electronic Equipment Cabinets.*
43. UL 497, *Standard for Safety Protectors for Paired Conductor Communications Circuits.*
44. UL 497C, *Protectors for Coaxial Communications Circuits.*
45. GR-2834-CORE, *Generic Requirements for Basic Electrical, Mechanical & Environmental Criteria for Outside Plant Equipment.*
46. UL 746C, *Polymeric Materials - Use in Electrical Equipment Evaluations.*
47. GR-2908-CORE, *Generic Requirements for Surge Protectors on Coaxial Lines at Customer Premises.*
48. ANSI T1.337/2003, *Requirements for Maximum Voltage, Current, and Power Levels in Network-Powered Transport Systems.*
49. *National Electrical Code (NEC), ANSI/NFPA 70-2005.*
50. ITU-T K.27 (05/96) Recommendation, *Bonding Configurations and Earthing Inside a Telecommunications Building.*
51. *National Electrical Safety Code, ANSI/IEEE C2-2002.*
52. IEEE Std. 802.3af-2003, *IEEE Standard for Information Technology - Telecommunications and Information Exchange Between Systems - Local and Metropolitan Area Networks - Specific Requirements.* (Superseded).
53. GR-513-CORE, *LSSGR: Power, Section 13 (a module of LSSGR, FR-64).*
54. ANSI T1.315-2001, *Voltage Levels for DC-Powered Equipment Used in Telecommunications Environment.*
55. IEC 61000-4-11 (2004-03) Second Edition, *Testing and measurement techniques - Voltage dips, short interruptions and voltage variations immunity tests.*
56. IEEE Std. 743-1995, *IEEE Standard Equipment Requirements and Measurement Techniques for Analog Transmission Parameters for Telecommunications.*
57. ITU-T K.35 (05/1996) Recommendation, *Bonding configurations and earthing at remote electronic sites.*

## Note

All Telcordia documents are subject to change, and their citations in this document reflect the most current information available at the time of this printing. Readers are advised to check current status and availability of all documents.

### To Contact Telcordia Customer Service or to Order Documents

Telcordia Customer Service  
One Telcordia Drive, Room 1B-180  
Piscataway, NJ 08854-4182  
1.866.672.6997 (USA)  
+ 1.732.699.6700 (Worldwide)  
+ 1.732.336.2226 (FAX)  
e-mail: [document-info@telcordia.com](mailto:document-info@telcordia.com)  
web site: <http://telecom-info.telcordia.com>

### To Order Documents Online From the Telcordia Information SuperStore

1. **Go to the SuperStore Web site:** <http://telecom-info.telcordia.com>  
(At this site, the **Search** and **Browse** selections provide access to the Telcordia catalog of technical information.)
2. If you know the document number, enter it in the **Search** box in the left margin and click **Go!**
3. Click on the desired product match.  
If you do not know the document number, do the following:
  1. Click on **Search** located on the top bar.
  2. In the **Keywords field**, enter the keywords (or document number), then click **Submit Search**.
  3. Click on the desired product match.

### To Order Documents From Within Telcordia (Employees Only)

1. Access the Telcordia Internal Home Page (InSite).
2. Click on **Self-Service** on the Navigation Bar.
3. Click on **Document Database**.
4. Click on **Basic Search** in the bullet list to obtain the Basic Search Criteria box.
5. In the Search by Document Number field, enter the document number (e.g., GR-454), then scroll down to click on **Submit Search**.
6. In the Basic Search Navigation List, select **Click for Abstract** to order an available document, or select **Click for Document** to view an available document.

### For New Information on Telcordia Technologies Technical Products

- **Digest** (*Free Download or E-mail Distribution List*)

Telcordia offers an electronic-only monthly publication — the *Digest of Technical Information*, which provides the latest information on GRs and other products. At the *Digest* Web site, you may view recent document releases and download the monthly *Digest* PDF files at no charge. For more information visit:

<http://www.telcordia.com/digest>

- **Digest Plus** (Free Subscription)

Telcordia also offers a printed publication — the *Digest Plus*, which includes a quarterly compilation of new document releases and other items that appeared in the monthly issues of the *Digest*. For more information visit:

<http://telecom-info.telcordia.com> (Click on Digest on the top.)

### To Obtain Additional Reference Material

Alliance for Telecommunications Industry Solutions (ATIS)	<a href="http://www.atis.org/">http://www.atis.org/</a>
American National Standards Institute (ANSI)	<a href="http://web.ansi.org/">http://web.ansi.org/</a>
American Society for Testing and Materials (ASTM)	<a href="http://www.astm.com/">http://www.astm.com/</a>
Canadian Standards Association (CSA)	<a href="http://www.csa.ca/">http://www.csa.ca/</a>
Electronic Code of Federal Regulations (e-CFR)	<a href="http://ecfr.gpoaccess.gov/">http://ecfr.gpoaccess.gov/</a>
Electronic Industries Alliance (EIA)	<a href="http://www.eia.org/">http://www.eia.org/</a>
Institute of Electrical and Electronics Engineers (IEEE)	<a href="http://ieee.org/">http://ieee.org/</a>
International Electrotechnical Commission (IEC)	<a href="http://www.iec.ch/">http://www.iec.ch/</a>
International Organization for Standardization (ISO)	<a href="http://www.iso.org/">http://www.iso.org/</a>
National Fire Protection Association (NFPA)	<a href="http://www.nfpa.org/">http://www.nfpa.org/</a>
Underwriters Laboratories (UL)	<a href="http://www.ul.com/">http://www.ul.com/</a>



## Appendix D: Definitions

This section defines key terms to help readers understand the contents of this GR.

A bracketed reference next to the term means the definition is consistent with the referenced document.

Term	Definition
<b>AC Power Port</b>	AC power port applies to equipment that provides an interface for connection directly to the ac mains.
<b>Agreed Primary Protection</b>	Agreed primary protection is a type of surge protector that is used to protect the equipment based on an agreement between the manufacturer and the LEC. Agreed primary protection may be a specific surge protector or a range of surge protectors which comply with a particular Telcordia Generic Requirements, national standard or international standard. GR-974-CORE and GR-1361-CORE specify a default agreed primary protector used in LEC facilities.
<b>Air Discharge Method<sup>[7]</sup></b>	A method of testing in which the charged electrode of the test generator is brought close to the EUT, and the discharge actuated by a spark to the EUT.
<b>Analog Voiceband Leads (applies only to Section 3)</b>	These leads apply to equipment ports that provide only voiceband services and are directly connected to the outside telecommunications cable plant in accordance with <a href="#">Appendix B</a> (e.g., Type 1 port).
<b>Antenna Port</b>	Antenna port applies to equipment that provides an interface for an antenna connection.
<b>Bonding (Equipotential Bonding)<sup>[49]</sup></b>	The permanent joining of metallic parts to form an electrically conductive path that ensures electrical continuity and the capacity to safely conduct any current likely to be imposed.
<b>Bonding Conductor</b>	A conductor or a combination of conductive parts in the equipment or facility providing equipotential bonding.
<b>Bonding Network (BN)<sup>[50]</sup></b>	A set of interconnected conductive structures that provides an electromagnetic shield for electronic systems and personnel at frequencies from DC to low frequency RF. The term “electromagnetic shield” denotes any structure used to divert, block or impede the passage of electromagnetic energy. A BN need not be connected to earth to function as an electromagnetic shield.  By definition, the bonding network includes the metallic frames of the equipment comprising the BN.
<b>Broadband Communications Equipment</b>	Equipment that is part of network-powered broadband communications systems that provide broadband services through a network interface unit in accordance with NEC Article 830.
<b>Burst<sup>[10]</sup></b>	Sequence of a limited number of distinct pulses or an oscillation of limited duration.
<b>Coaxial Cable Port</b>	Coaxial cable port applies to equipment that has coaxial cable interfaces in a telecommunications network.



<b>Common Bonding Network (CBN)</b> <sup>[50]</sup>	The CBN is the principal means for effecting bonding and earthing inside a telecommunications building. It is the set of metallic components that are intentionally or incidentally interconnected to form the principal BN in a building. These components include: structural steel or reinforcing rods, metallic plumbing, AC power conduit, ACEG conductors, cable racks, bonding conductors and CO GRD system. The CBN typically has a mesh topology and is connected to the Grounding Electrode System.
<b>Common DC Return (DC-C)</b> <sup>[50]</sup>	A dc power system in which the DC return terminal or conductor is connected to the equipment frame or to the grounding means of the equipment.
<b>Common Mode (coupling)</b> <sup>[10]</sup>	Simultaneous coupling to all lines versus the ground reference plane.
<b>Contact Discharge Method</b> <sup>[7]</sup>	A method of testing in which the electrode of the test generator is held in contact with the EUT, and the discharge actuated by the discharge switch within the generator.
<b>Coupling</b> <sup>[10]</sup>	Interaction between circuits, transferring energy from one circuit to another.
<b>Coupling Clamp</b> <sup>[10]</sup>	Device of defined dimensions and characteristics for common mode coupling of the disturbance signal to the circuit under test without any galvanic connection to it.
<b>Coupling Network</b> <sup>[10]</sup>	Electrical circuit for the purpose of transferring energy from one circuit to another.
<b>Coupling Plane</b> <sup>[7]</sup>	A metal sheet or plate to which discharges are applied to simulate electrostatic discharge to objects adjacent to the EUT. HCP: Horizontal Coupling Plane; VCP: Vertical Coupling Plane
<b>DC Power Port</b>	DC power port applies to equipment that provides an interface for connection directly to the dc mains.
<b>Decoupling Network</b> <sup>[10]</sup>	Electrical circuit for the purpose of preventing EFT voltage applied to the EUT from affecting other devices, equipment or systems which are not under test.
<b>EFT/Burst</b> <sup>[10]</sup>	Electrical fast transient/burst.
<b>Electronic Equipment Cabinet (EEC)</b> <sup>[57]</sup>	An EEE for which all installed equipment can be fully accessed from the outside without having to enter an interior area.
<b>Electronic Equipment Enclosure (EEE)</b> <sup>[57]</sup>	A structure that provides physical and environmental protection for electronic communication equipment, and that: <ul style="list-style-type: none"> <li>• Has only one level</li> <li>• Has a floor space of no more than about 100 m<sup>2</sup></li> <li>• Has a need for a.c. mains power service.</li> </ul> EEEs typically include CEVs and huts.
<b>Electrostatic Discharge (ESD)</b> <sup>[7]</sup>	A transfer of electric charge between bodies of different electrostatic potential in proximity or through direct contact.



<b>Equipment with Integrated Primary Protection (EIPP)</b>	<p>Equipment is classified as having integrated primary protection if the primary protector(s) and the associated electronic circuitry are contained within or are part of the same equipment or enclosure.</p> <p><b>NOTE:</b> NIDs and other similar equipment fall within this classification.</p> <p><b>NOTE:</b> The equipment manufacturer may supply the equipment with integrated primary protection with the primary protectors already installed, or the primary protectors may be installed by the LEC.</p>
<b>Equipment with Embedded Primary Protection (EPPP)</b>	<p>Equipment is classified as having embedded primary protection if the primary protector(s) and the associated electronic circuitry are contained within or are part of the same equipment or enclosure. In addition, the primary protection mounting mechanism (i.e., circuit board, holder, etc.) and the primary protector(s) are not intended to be field serviceable. Equipment with embedded primary protection is a subset of equipment with integrated primary protection.</p> <p><b>NOTE:</b> Equipment that contains embedded primary protection is expected to be shipped to the customer with the primary protector(s) already installed.</p>
<b>Fault Current</b>	A current resulting from an insulation failure or the bridging of insulation.
<b>Ground</b> <sup>[49]</sup>	A conducting connection, whether intentional or accidental, between an electrical circuit or equipment and the earth or to some conducting body that serves in place of the earth.
<b>Grounded</b> <sup>[49]</sup>	<p>Connected to earth or to some conducting body that serves in place of the earth.</p> <p>An office grounding electrode system is an example of the conducting bodies that serve as a connections to the earth.</p>
<b>Grounding Conductor</b> <sup>[49]</sup>	A conductor used to connect equipment or the grounded circuit of a wiring system to a grounding electrode or electrodes.
<b>Grounding Electrode Conductor</b> <sup>[49]</sup>	The conductor used to connect the grounding electrode to the equipment grounding conductor and/or to the grounded conductor of the circuit at the service equipment or at the source of a separately derived system.
<b>Incidental Connection</b>	<p>An unplanned connection between conductive parts.</p> <p>Examples: Incidental connections usually occur during the mechanical assembly and installation of frames, raceways, piping, ducts, superstructure, and other conductive objects. When the frames are bolted to adjacent frames, a superstructure, and/or the superstructure-to-ceiling inserts in contact with building structural steel, they can form incidental connections.</p> <p>Incidental connections should not be depended on to produce a reliable electrical connection. Painted and oxidized surfaces and loose mechanical connections tend to insulate adjacent conducting surfaces.</p>
<b>Immunity (to a disturbance)</b> <sup>[7]</sup>	The ability of a device, equipment or system to perform without degradation in the presence of an electromagnetic disturbance.

<b>Isolated Bonding Network (IBN)</b> <sup>[50]</sup>	A bonding network that has a Single Point of Connection (SPC) to either the common bonding network or another isolated bonding network.
<b>Isolated DC Return (DC-I)</b> <sup>[50]</sup>	A dc power system in which the dc return terminal or conductor is not connected to the equipment frame or the grounding means of the equipment.
<b>Listed</b> <sup>[49]</sup>	Equipment included in a list published by an organization that is concerned with evaluation of products, that maintains period inspection of production of listed equipment, and whose listing states that the equipment has been tested and found suitable for a specific purpose.
<b>Necessary Bandwidth</b> <sup>[11]</sup>	For a given class of emission, the width of the frequency band which is just sufficient to ensure the transmission of information at the rate and with the quality required under specified conditions.
<b>Raceway</b> <sup>[49]</sup>	An enclosed channel designed expressly for holding wires, cables, or bus bars, with additional functions as permitted in National Electrical Code. Raceways include, but are not limited to, rigid metal conduit, rigid non-metallic conduit, intermediate metal conduit, liquid-tight flexible conduit, flexible metallic tubing, flexible metal conduit, electrical non-metallic tubing, electrical metallic tubing, underfloor raceways, cellular concrete floor raceways, cellular metal floor raceways, surface raceways, wireways, and busways.
<b>Shared power plant</b>	A power plant that simultaneously feeds multiple telecommunications load equipment.
<b>Shrouded and Guarded</b>	<p>A shrouded or guarded connection is a connection means where inadvertent access with the sources is unlikely. The shrouded or guarded connection shall have the following characteristics:</p> <ul style="list-style-type: none"> <li>• Contact by a large part of the human body, such as the back of the hand, is impossible;</li> <li>• Contact is possible only by deliberately inserting a small part of the body, less than 12 mm across, such as a fingertip, which presents a high impedance;</li> <li>• In case of AC voltage, the possibility of being unable to let go of the part in contact does not arise.</li> </ul> <p>Examples of compliant shrouded connections are as follows: modular plugs and jacks, miniature ribbon cables, and D sub-miniature connectors.</p>
<b>Signal Leads (applies only to Section 3)</b>	<p>These leads apply to equipment ports that</p> <ul style="list-style-type: none"> <li>• Are not directly connected to outside telecommunications cable plant in accordance with <a href="#">Appendix B</a> (e.g., Type 2 port).</li> <li>• Are directly connected to the outside telecommunications cable plant in accordance with <a href="#">Appendix B</a> (e.g., Type 1 port) and are not voiceband or telecommunications leads.</li> </ul> <p>Examples of signal leads are leads that connect to equipment not furnished with the EUT (such as personal computers or alarm-system panels). Other examples of signal leads are legacy systems such as a DS1 system and analog carrier technologies.</p>

<b>Single Point Connection (SPC)</b> <sup>[50]</sup>	The unique location in an IBN where a connection is made to the CBN. In reality, the SPC is not a 'point' but, of necessity, has sufficient size to accommodate the connection of conductors. Usually, the SPC takes the form of a copper busbar. If cable shields or coaxial outer conductors are to be connected to the SPC, the SPC could be a frame with a grid or sheet metal structure.
<b>Solid Connection</b>	A connection between conductive parts which has NO additional impedance intentionally connected in series with the wire.
<b>Solidly Grounded</b>	A method of grounding either a power supply or a frame that uses a grounding wire connection which has NO additional impedance intentionally connected in series with the grounding path.
<b>Sources (applies only to Section 7)</b>	This term as used in this section is intended to apply to intentionally energized communications circuits (e.g., conductors, terminals, connectors, components, wire wrap pins). It also applies to any other conductive parts located where incidental contact or maintenance procedures could reasonably result in contact while the equipment is energized.
<b>Telecommunications Leads (applies only to Section 3)</b>	These leads apply to equipment ports that <ul style="list-style-type: none"> <li>• Provide Digital Subscriber Lines (DSL) technologies or other high-speed digital services and are directly connected to the outside telecommunications cable plant in accordance with <a href="#">Appendix B</a> (e.g., Type 1 port).</li> <li>• Provide power of not greater than 100 VA to remote telecommunications equipment over outside plant telecommunications circuits in accordance with Section 7.6 (e.g., Type 1 and 3 ports).</li> </ul>
<b>Telecommunications Port</b>	Telecommunications port applies to equipment that have paired-conductor interfaces in a telecommunications network (such as T and R leads, sleeve leads, E & M leads). For example, 10BaseT and 100BaseT Ethernet and other similar ports are considered telecommunications ports. Telecommunications ports include ports that provide power to remote telecommunications equipment over outside plant telecommunications circuits.
<b>Type Test</b>	In terms of this document, a "Type Test" is a test or evaluation utilizing the minimum number of ports necessary to determine conformance or non-conformance for one or more ports representing the production. Typically, this number is one. However, in some cases multiple ports may be necessary to ensure adequate evaluation of the product.
<b>Unwanted Emissions</b> <sup>[11]</sup>	Spurious and out-of-band emissions on frequency or frequencies outside of the necessary bandwidth.



## Appendix E: Acronyms

<b>AC</b> — Alternating Current	<b>EEC</b> — Electronic Equipment Cabinet
<b>ACEG</b> — Alternating Current Equipment Ground	<b>EEE</b> — Electronic Equipment Enclosure
<b>ACTA</b> — Administrative Council on Technical Attachments	<b>EAPP</b> — Equipment with Embedded Primary Protection
<b>ADSL</b> — Asymmetric Digital Subscriber Line	<b>EFT</b> — Electrical Fast Transient
<b>AMA</b> — Automatic Message Accounting	<b>EIA</b> — Electronics Industries Alliance
<b>AMN</b> — Artificial Main Network	<b>EIPP</b> — Equipment with Integrated Primary Protection
<b>ANSI</b> — American National Standards Institute	<b>EMC</b> — Electromagnetic Compatibility
<b>AWG</b> — American Wire Gauge	<b>EMI</b> — Electromagnetic Interference
<b>BER</b> — Bit Error Rate	<b>ESD</b> — Electrostatic Discharge
<b>BR</b> — Battery Return	<b>EUT</b> — Equipment Under Test
<b>CB</b> — Citizen Band	<b>FA</b> — Framework Advisory (a type of Telcordia document Telcordia)
<b>CBN</b> — Common Bonding Network	<b>FCC</b> — Federal Communications Commission
<b>CEV</b> — Controlled Environmental Vault	<b>FR</b> — Family of Requirements
<b>CFR</b> — Code of Federal Regulations	<b>GDT</b> — Gas Discharge Tube
<b>CISPR</b> — Comite International Special des Perturbations Radioelectriques	<b>GR</b> — Generic Requirements document
<b>CO</b> — Central Office	<b>GTPU</b> — Gas Tube Protector Unit
<b>COAX</b> — Coaxial Cable	<b>HDLS</b> — High Data Rate Digital Subscriber Line
<b>CO GRD</b> — Central Office Ground	<b>HDSL</b> — High bit-rate Digital Subscriber Line
<b>COT</b> — Central Office Terminal	<b>IBN</b> — Isolated Bonding Network
<b>CSA</b> — Carrier Serving Area	<b>IEC</b> — International Electrotechnical Commission
<b>DC</b> — Direct Current	<b>IEEE</b> — The Institute of Electrical and Electronics Engineers
<b>DC-C</b> — Common DC return	<b>IF</b> — Interconnecting Frame
<b>DC-I</b> — Isolated DC return	<b>ISDN</b> — Integrated Services Digital Network
<b>DLC</b> — Digital Loop Carrier	<b>ISM</b> — Industrial Scientific Medical. Describes several frequency bands in the radio spectrum.
<b>DSL</b> — Digital Subscriber Line	<b>ISN</b> — Impedance Stabilization Network
<b>DSLAM</b> — Digital Subscriber Line Access Multiplexer	<b>ITU</b> — International Telecommunication
<b>DSX</b> — Digital Signal Cross-Connect	
<b>E &amp; M leads</b> — rEceive and transMit or Ear and Mouth.	

Union	<b>PBX</b> — Private Branch Exchange
<b>LATA</b> — Local Access Transport Area	<b>PCB</b> — Printed Circuit Board
<b>LCL</b> — Longitudinal Conversion Loss	<b>PCN</b> — Product Change Notice
<b>LEC</b> — Local Exchange Carrier	<b>PCS</b> — Personal Communications Service
<b>LISN</b> — Line Impedance Stabilization Network	<b>POTS</b> — Plain Old Telephone Service
<b>LSSGR</b> — LATA Switching Systems Generic Requirements	<b>PVC</b> — Polyvinyl Chloride
<b>LT</b> — Line Termination	<b>RCA</b> — Root Cause Analysis
<b>MDF</b> — Main Distribution Frame	<b>RF</b> — Radio Frequency
<b>MLT</b> — Mechanized Loop Testing (System)	<b>RMS</b> — Root-Mean-Square, denoted as “rms” in equations or when combined with the voltage (V) abbreviation such as in “Vrms”
<b>MTIE</b> — Maximum Time Interval Error	<b>ROI</b> — Requirement Object Index
<b>MOV</b> — Metal Oxide Varistor	<b>RT</b> — Remote Terminal
<b>NEBS</b> — Network Equipment-Building System	<b>SC</b> — Short-Circuit
<b>NEC</b> — National Electrical Code	<b>SCP</b> — Single Point of Connection
<b>NESC</b> — National Electrical Safety Code	<b>SDSL</b> — Single-line Digital Subscriber Line
<b>NFPA</b> — National Fire Protection Association	<b>SPCSS</b> — Stored Program Control Switching System
<b>NID</b> — Network Interface Device	<b>SPD</b> — Surge Protective Device
<b>NIU</b> — Network Interface Unit	<b>STP</b> — Signal Transfer Point
<b>NMS</b> — Noise Measuring Set	<b>T</b> — Tip Conductor
<b>NRTL</b> — Nationally Recognized Testing Laboratory	<b>TA</b> — Technical Advisory and/or Technical Adaptor
<b>NT</b> — Network Termination	<b>TEM</b> — Transverse Electromagnetic
<b>NT1</b> — Network Termination 1	<b>TIA</b> — Telecommunications Industry Association
<b>NT2</b> — Network Termination 2	<b>TLPU</b> — Telecommunications Line Protector Unit
<b>OC</b> — Open-Circuit	<b>TR</b> — Technical Reference
<b>OATS</b> — Open-Area Test Site	<b>TSGR</b> — Transport Systems Generic Requirements
<b>ONT</b> — Optical Network Terminal	<b>UL</b> — Underwriters Laboratory
<b>ONU</b> — Optical Network Unit	
<b>OSHA</b> — Occupational Safety and Health Administration	
<b>OTGR</b> — Operations Technology Generic Requirements	
<b>ORB</b> — Office Repeater Bay	

## Requirement-Object Index

[1] ... R2-1 ..... Page 2-1	[48] .. R5-7 ..... Page 5-14	[92] .. R9-28 ..... Page 9-14
[2] ... R2-2 ..... Page 2-2	[49] .. R5-8 ..... Page 5-22	[93] .. R9-29 ..... Page 9-17
[3] ... R2-3 ..... Page 2-2	[50] .. CR5-9 ..... Page 5-22	[94] .. R4-66 ..... Page 4-79
[4] ... O2-4 ..... Page 2-2	[51] .. R5-10 ..... Page 5-22	[95] .. R4-67 ..... Page 4-79
[5] ... R2-5 ..... Page 2-2	[52] .. CR5-11 ..... Page 5-22	[96] .. R4-68 ..... Page 4-79
[6] ... R2-6 ..... Page 2-3	[53] .. R6-1 ..... Page 6-1	[97] .. CR4-69 ..... Page 4-79
[7] ... R2-7 ..... Page 2-3	[54] .. R7-7 ..... Page 7-16	[99] .. R4-70 ..... Page 4-80
[8] ... R3-2 ..... Page 3-5	[55] .. R7-8 ..... Page 7-16	[100] . R4-71 ..... Page 4-80
[9] ... O3-3 ..... Page 3-7	[56] .. R7-9 ..... Page 7-16	[101] . R4-72 ..... Page 4-80
[10] .. R3-4 ..... Page 3-7	[57] .. R7-10 ..... Page 7-16	[102] . CR4-73 ..... Page 4-81
[11] .. R3-9 ..... Page 3-10	[58] .. R7-11 ..... Page 7-16	[103] . R4-74 ..... Page 4-81
[12] .. R3-10 ..... Page 3-11	[59] .. R7-12 ..... Page 7-17	[104] . R4-75 ..... Page 4-82
[13] .. R3-11 ..... Page 3-11	[60] .. R7-13 ..... Page 7-17	[105] . R4-76 ..... Page 4-83
[14] .. R3-13 ..... Page 3-13	[61] .. R7-14 ..... Page 7-17	[106] . O4-77 ..... Page 4-83
[15] .. R3-15 ..... Page 3-18	[62] .. R7-15 ..... Page 7-17	[107] . R4-78 ..... Page 4-83
[16] .. R3-16 ..... Page 3-18	[63] .. R7-16 ..... Page 7-17	[108] . R4-79 ..... Page 4-84
[17] .. R3-17 ..... Page 3-18	[64] .. R7-17 ..... Page 7-17	[109] . R4-80 ..... Page 4-86
[18] .. R3-18 ..... Page 3-18	[65] .. R7-18 ..... Page 7-18	[110] . R4-81 ..... Page 4-86
[19] .. R3-19 ..... Page 3-18	[66] .. R7-19 ..... Page 7-18	[111] . O4-82 ..... Page 4-86
[20] .. R4-2 ..... Page 4-11	[67] .. R7-21 ..... Page 7-19	[112] . R4-83 ..... Page 4-87
[22] .. R7-1 ..... Page 7-1	[68] .. R7-22 ..... Page 7-20	[113] . R4-86 ..... Page 4-88
[23] .. R7-2 ..... Page 7-1	[69] .. R7-23 ..... Page 7-22	[114] . R4-87 ..... Page 4-89
[24] .. R7-3 ..... Page 7-2	[70] .. R7-24 ..... Page 7-22	[115] . R7-5 ..... Page 7-3
[25] .. R4-5 ..... Page 4-22	[71] .. R7-25 ..... Page 7-22	[116] . R9-4 ..... Page 9-3
[26] .. R4-1 ..... Page 4-6	[72] .. O8-1 ..... Page 8-1	[117] . CR9-30 ..... Page 9-20
[27] .. R4-6 ..... Page 4-24	[73] .. O8-2 ..... Page 8-1	[118] . R9-31 ..... Page 9-20
[29] .. R4-10 ..... Page 4-28	[74] .. R9-1 ..... Page 9-1	[119] . CR9-32 ..... Page 9-21
[30] .. R4-12 ..... Page 4-31	[75] .. R9-2 ..... Page 9-2	[120] . CR9-36 ..... Page 9-26
[31] .. R4-13 ..... Page 4-31	[76] .. R9-3 ..... Page 9-2	[121] . CR9-33 ..... Page 9-22
[32] .. R4-90 ..... Page 4-91	[77] .. R9-5 ..... Page 9-4	[122] . CR9-34 ..... Page 9-24
[33] .. R4-91 ..... Page 4-91	[78] .. R9-7 ..... Page 9-5	[123] . CO9-35 ..... Page 9-24
[34] .. R4-20 ..... Page 4-40	[79] .. R9-10 ..... Page 9-6	[125] . R4-35 ..... Page 4-57
[35] .. R4-17 ..... Page 4-36	[80] .. R9-14 ..... Page 9-9	[126] . O2-8 ..... Page 2-6
[36] .. R4-23 ..... Page 4-45	[81] .. R9-15 ..... Page 9-9	[128] . R3-12 ..... Page 3-12
[37] .. R4-26 ..... Page 4-48	[82] .. R9-18 ..... Page 9-13	[129] . O3-14 ..... Page 3-14
[39] .. R4-27 ..... Page 4-49	[83] .. R9-19 ..... Page 9-13	[130] . R3-20 ..... Page 3-19
[40] .. R4-34 ..... Page 4-57	[84] .. R9-20 ..... Page 9-13	[131] . R3-21 ..... Page 3-19
[41] .. R4-36 ..... Page 4-58	[85] .. R9-21 ..... Page 9-13	[133] . O4-8 ..... Page 4-27
[42] .. R5-1 ..... Page 5-7	[86] .. R9-22 ..... Page 9-13	[134] . R4-9 ..... Page 4-27
[43] .. CR5-2 ..... Page 5-7	[87] .. R9-23 ..... Page 9-13	[135] . CR4-21 ..... Page 4-40
[44] .. R5-3 ..... Page 5-7	[88] .. R9-24 ..... Page 9-13	[136] . CO4-22 ..... Page 4-40
[45] .. CR5-4 ..... Page 5-7	[89] .. R9-25 ..... Page 9-14	[137] . R4-28 ..... Page 4-52
[46] .. R5-5 ..... Page 5-12	[90] .. R9-26 ..... Page 9-14	[138] . R4-31 ..... Page 4-56
[47] .. R5-6 ..... Page 5-13	[91] .. R9-27 ..... Page 9-14	[139] . R4-32 ..... Page 4-56



[140] . R4-33 . . . . Page 4-56	[186] . R4-45 . . . . Page 4-68
[141] . R5-12 . . . . Page 5-25	[187] . R4-46 . . . . Page 4-68
[142] . O5-13 . . . . Page 5-25	[188] . R4-47 . . . . Page 4-68
[143] . R7-4 . . . . . Page 7-2	[189] . R4-48 . . . . Page 4-68
[144] . R7-6 . . . . . Page 7-4	[190] . R4-49 . . . . Page 4-68
[145] . R7-20 . . . . Page 7-18	[191] . R4-50 . . . . Page 4-69
[146] . R9-8 . . . . . Page 9-5	[192] . R4-51 . . . . Page 4-71
[147] . R9-9 . . . . . Page 9-6	[193] . R4-52 . . . . Page 4-72
[148] . R9-11 . . . . Page 9-7	[194] . R4-53 . . . . Page 4-73
[149] . R9-12 . . . . Page 9-8	[195] . R4-54 . . . . Page 4-73
[150] . R9-13 . . . . Page 9-8	[196] . R4-55 . . . . Page 4-73
[151] . R9-16 . . . . Page 9-12	[197] . R4-56 . . . . Page 4-73
[152] . R9-17 . . . . Page 9-12	[198] . R4-57 . . . . Page 4-73
[153] . R1-1 . . . . . Page 1-10	[199] . R4-58 . . . . Page 4-74
[154] . R1-2 . . . . . Page 1-10	[200] . R4-59 . . . . Page 4-76
[155] . R1-3 . . . . . Page 1-10	[201] . R4-60 . . . . Page 4-76
[156] . R1-4 . . . . . Page 1-10	[202] . R4-61 . . . . Page 4-76
[157] . R1-5 . . . . . Page 1-10	[203] . R4-62 . . . . Page 4-77
[158] . R1-6 . . . . . Page 1-10	[204] . R4-63 . . . . Page 4-77
[159] . R3-1 . . . . . Page 3-4	[205] . CR4-64 . . . . Page 4-78
[160] . R3-5 . . . . . Page 3-9	[206] . CR4-65 . . . . Page 4-78
[161] . R3-6 . . . . . Page 3-9	[207] . O4-84 . . . . Page 4-87
[162] . R3-7 . . . . . Page 3-9	[208] . R4-85 . . . . Page 4-88
[163] . O3-8 . . . . . Page 3-10	[209] . R4-88 . . . . Page 4-89
[164] . O3-22 . . . . Page 3-19	[210] . R4-89 . . . . Page 4-90
[165] . O4-3 . . . . . Page 4-13	[211] . R4-92 . . . . Page 4-92
[166] . O4-4 . . . . . Page 4-13	[212] . CO4-93 . . . . Page 4-93
[167] . R4-7 . . . . . Page 4-24	[213] . R9-6 . . . . . Page 9-4
[168] . R4-11 . . . . Page 4-29	[214] . R9-37 . . . . Page 9-28
[169] . R4-14 . . . . Page 4-31	[215] . R9-38 . . . . Page 9-28
[170] . O4-15 . . . . Page 4-35	[216] . R9-39 . . . . Page 9-29
[171] . R4-16 . . . . Page 4-35	[217] . R9-40 . . . . Page 9-29
[172] . R4-18 . . . . Page 4-36	[218] . O10-1 . . . . Page 10-1
[173] . R4-19 . . . . Page 4-37	[219] . O10-2 . . . . Page 10-1
[174] . R4-24 . . . . Page 4-46	[220] . O10-3 . . . . Page 10-2
[175] . R4-25 . . . . Page 4-47	[221] . O10-4 . . . . Page 10-2
[176] . R4-29 . . . . Page 4-53	[222] . O10-5 . . . . Page 10-3
[177] . R4-30 . . . . Page 4-54	[223] . O10-6 . . . . Page 10-4
[178] . CO4-37 . . . . Page 4-59	[224] . CO10-7 . . . . Page 10-4
[179] . R4-38 . . . . Page 4-61	[225] . O10-8 . . . . Page 10-5
[180] . R4-39 . . . . Page 4-61	[226] . O10-9 . . . . Page 10-5
[181] . R4-40 . . . . Page 4-62	[227] . O10-10 . . . . Page 10-5
[182] . R4-41 . . . . Page 4-65	[228] . O10-11 . . . . Page 10-6
[183] . R4-42 . . . . Page 4-66	[229] . O10-12 . . . . Page 10-6
[184] . R4-43 . . . . Page 4-67	[230] . O10-13 . . . . Page 10-6
[185] . R4-44 . . . . Page 4-68	